

SERVICE MANUAL

S24 (9+9) SHUTTLE XL
Transmission

SERVICE MANUAL

ITL

9+9 SPEED TRANSMISSION

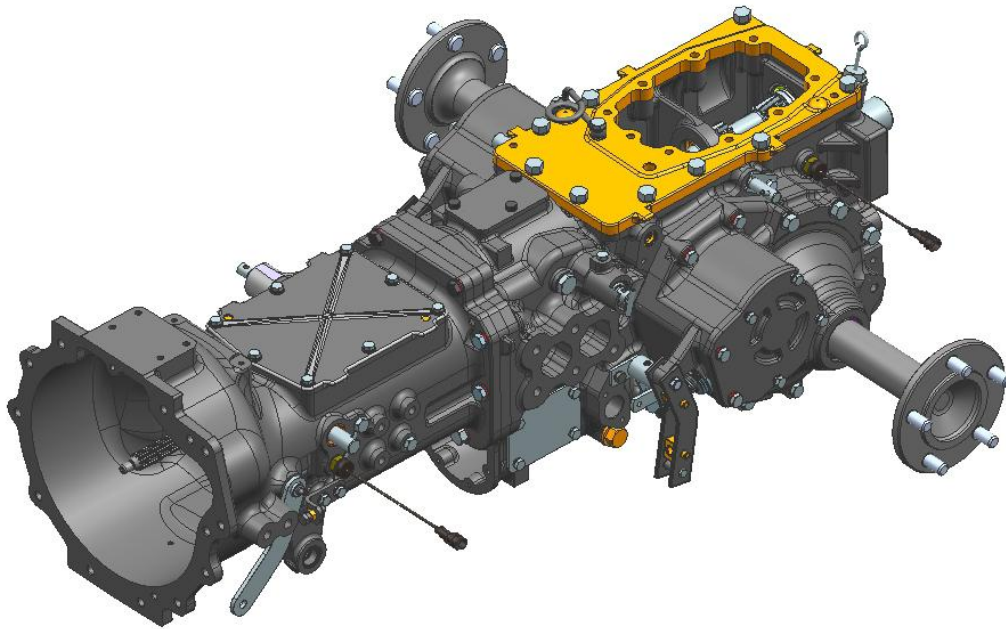

INTERNATIONAL TRACTORS USA CORPORATION

2332 MT. ZION ROAD

GREEN WOOD, AR

Publication No:
Published On:

Differential and Rear Axle Assembly

CONTENTS

REF. NO.	DESCRIPTION	PAGE
A.1	Main Dimension	2-3
B.1	Transmission Oil Filler Plug/Dipstick	4
C.1	Sealant and Adhesives	4
D.1	9+9 Power Flow Chart	5-11
E.1	Filling and Checks	12
F.1	Service Schedule	12
G.1	Special Service Tool	13-18
A.2	Disassembly of Gear Box	21-27
B.2	Disassembly of Lay Shaft	28-30
C.2	Disassembly of Intermediate Shaft	31-32
A.3	Disassembly of Differential Housing	35-42
B.3	Disassembly of Trumpet Housing	43-44
C.3	Disassembly of Tail Pinion Shaft	45-47
D.3	Disassembly of Range Lay Shaft	48
E.3	Disassembly of Differential Sub Cage	49-51
A.4	Torque Chart-Gear Box	52-53
B.4	Inspection of Synchronizer Assembly	54-55
C.4	Assembly of Synchronizer	56
D.4	Slip Clutch Assembly	57
E.4	Assembly of Gear Box	58-72
F.4	Lay Shaft Assembly	60-61
G.4	Intermediate Shaft Assembly	64
A.5	Torque Chart-Differential Housing	74
B.5	Assembly of Cage Sub Assembly	75-77
C.5	Assembly of Tail Pinion Shaft	78-80
D.5	Assembly of Range Lay Shaft	81
E.5	4WD Shaft Sub Assembly	82-83
F.5	Rear PTO Assembly	84-87
G.5	Assembly of Trumpet Housing	88-90
H.5	Assembly of Differential Housing	91-103
I.5	Differential Backlash Adjustment	98
J.5	Troubleshooting	104-105

A.1 Main Dimensions(mm)

A.1.a TRANSMISSION

Top View (See Main View)

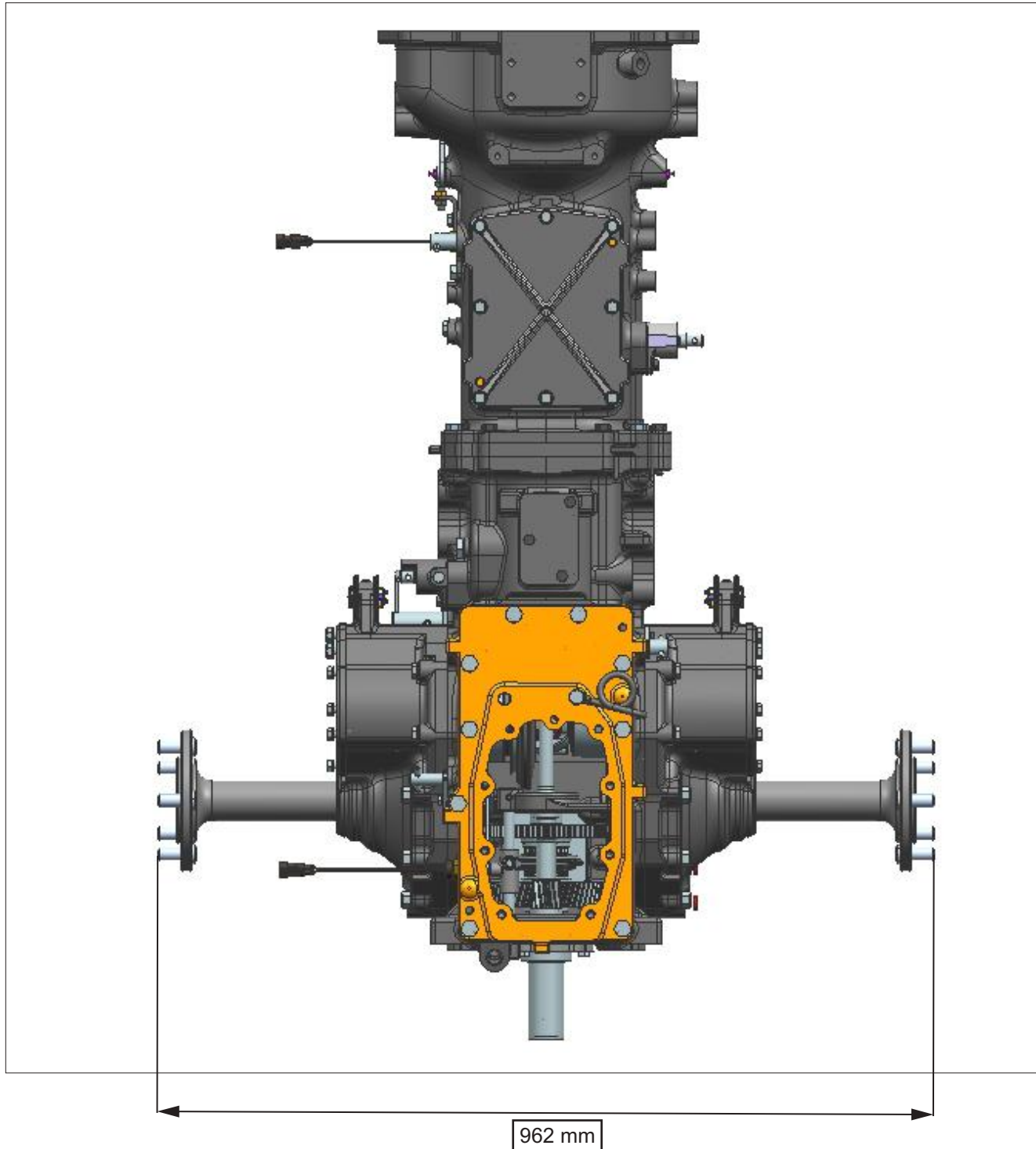

A.1 Main Dimensions(mm)

LHS View (See Main View)

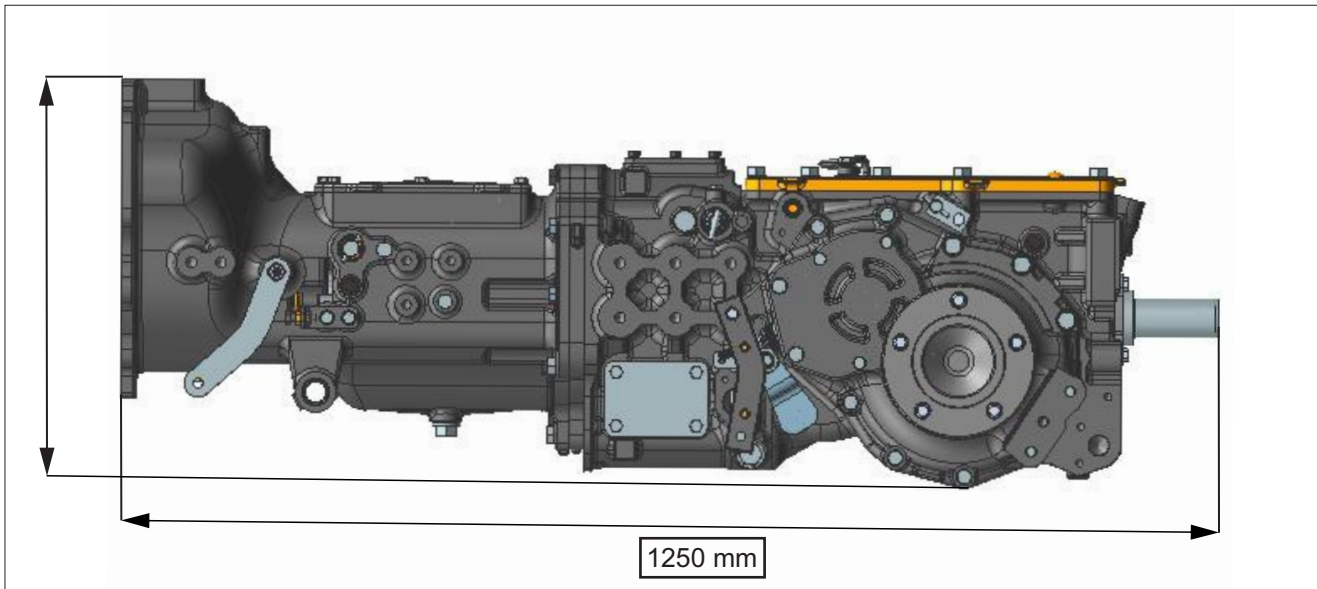

A.1.b Transmission Oil Drain Plugs :

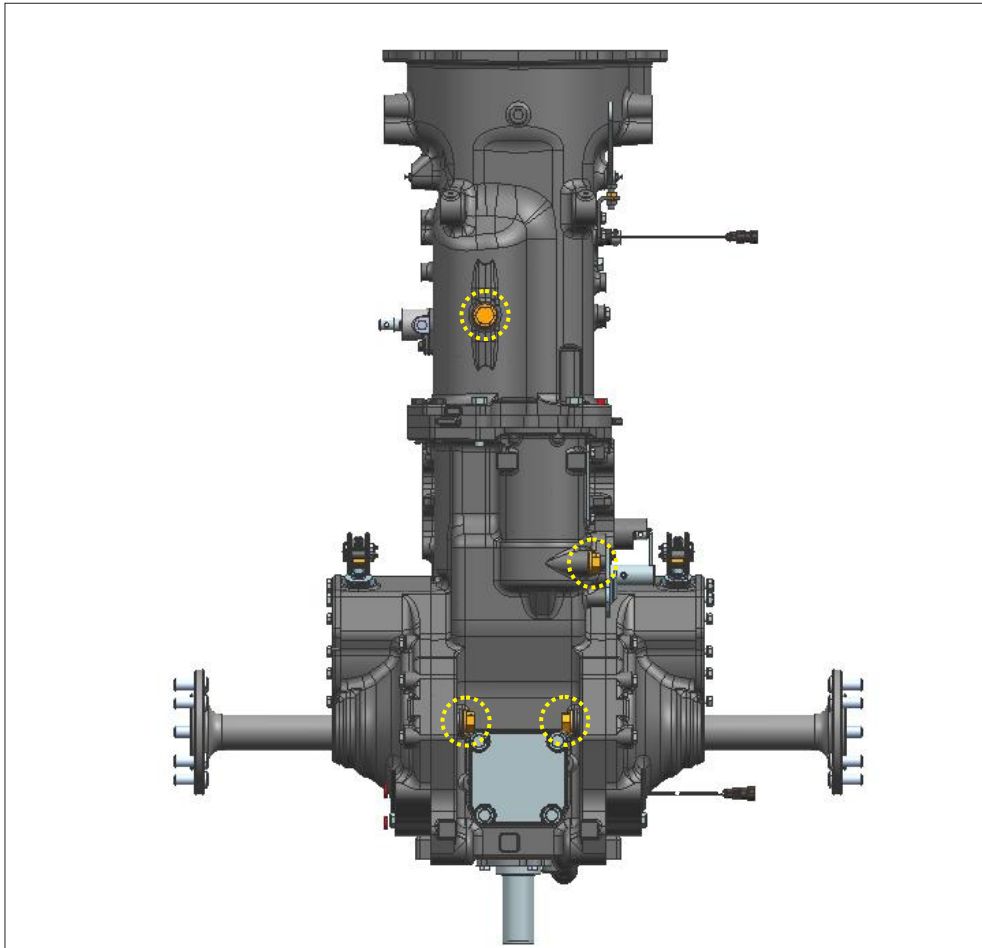

B.1 Transmission Oil Filler Plug/Dipstick

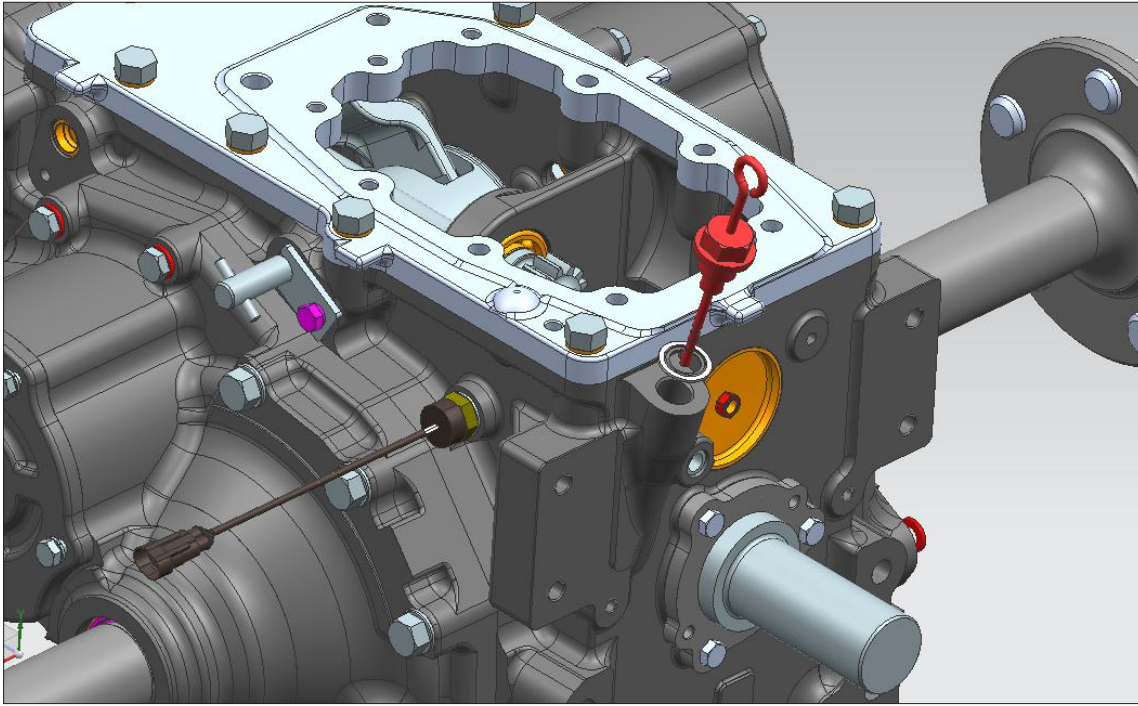

B.1.a Transmission Oil :-

- Capacity : 6.08 gallon(32 Litres).
- Grade : SAE-80W.
- Replacement : Every 1000 Hours.

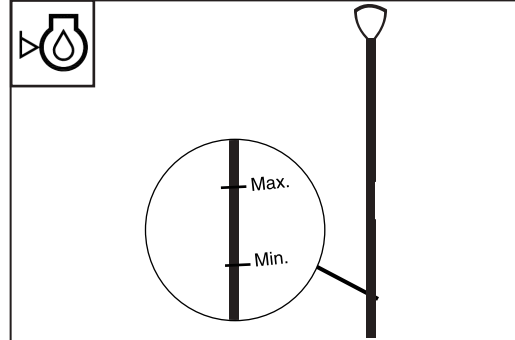

Dipstick marks

C.1 Sealant and Adhesives

Gasket Sealant and Loctite	
Adhesive make and type	Technical characteristics
Sealant 5188	Flat surface sealing
Loctite 243	Bolt and Nut
Loctite 262	Tail Pinion Nut
Loctite 638	Transmission Caps

D.1 9+9 Power Flow Chart

FL	Forward Low	FH	Forward High	RM	Reverse Medium
FM	Forward Medium	RL	Reverse Low	RH	Reverse High

1. FL1 POWER FLOW:-

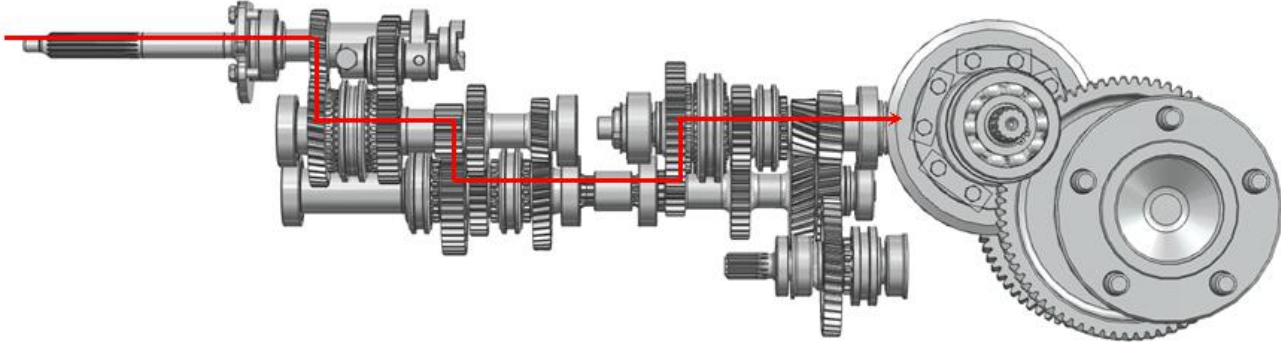

2. FL2 POWER FLOW:-

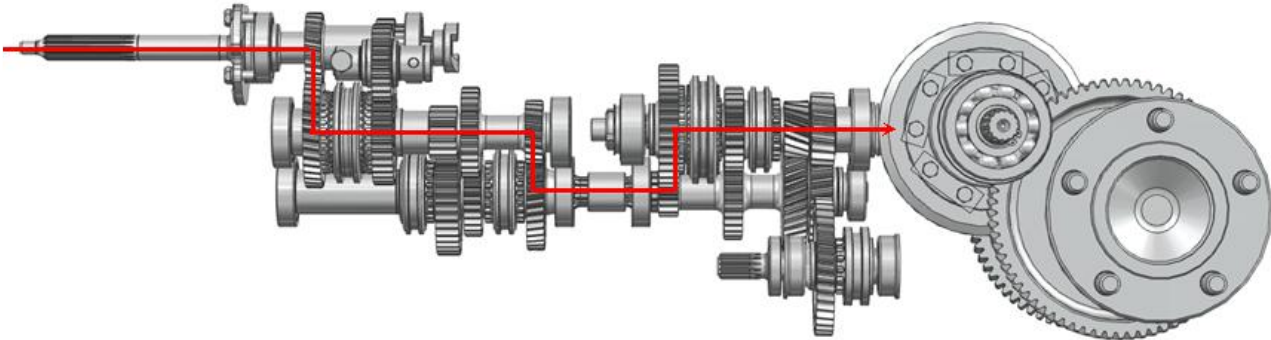

3. FL3 POWER FLOW:-

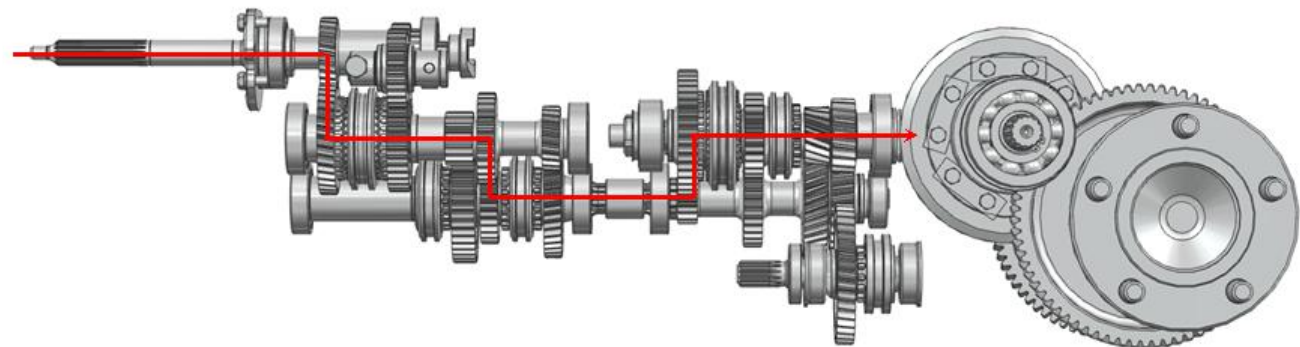

D.1 9+9 Power Flow Chart

1. FM1 POWER FLOW:-

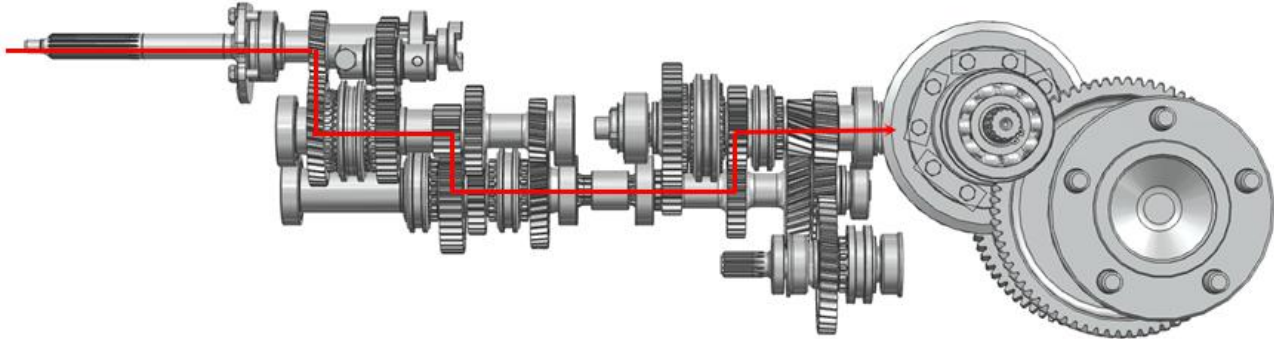

2. FM2 POWER FLOW:-

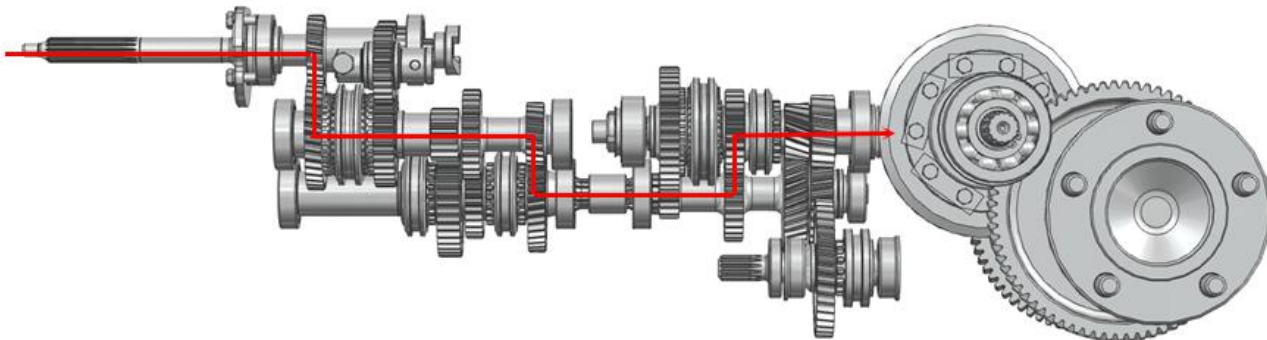

3. FM3 POWER FLOW:-

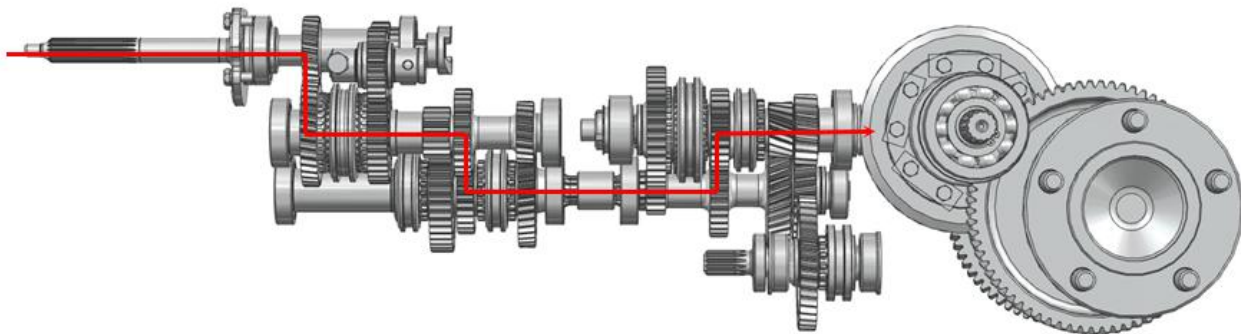

D.1 9+9 Power Flow Chart

1. RL1 POWER FLOW:-

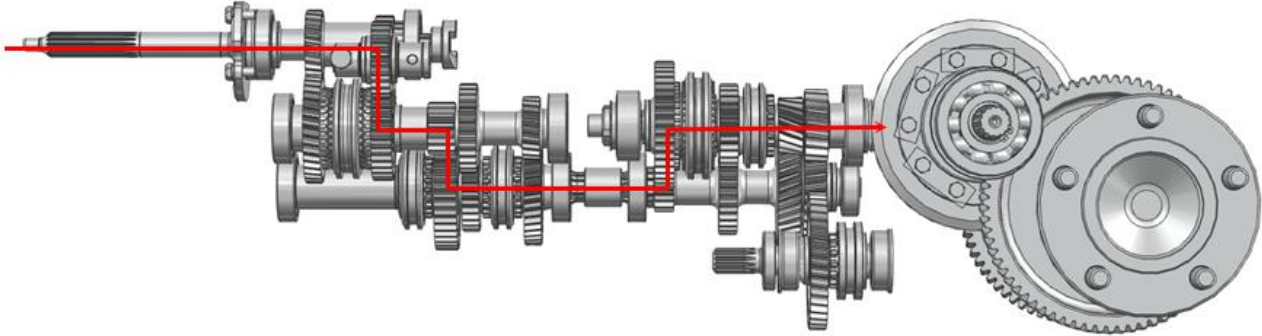

2. RL2 POWER FLOW:-

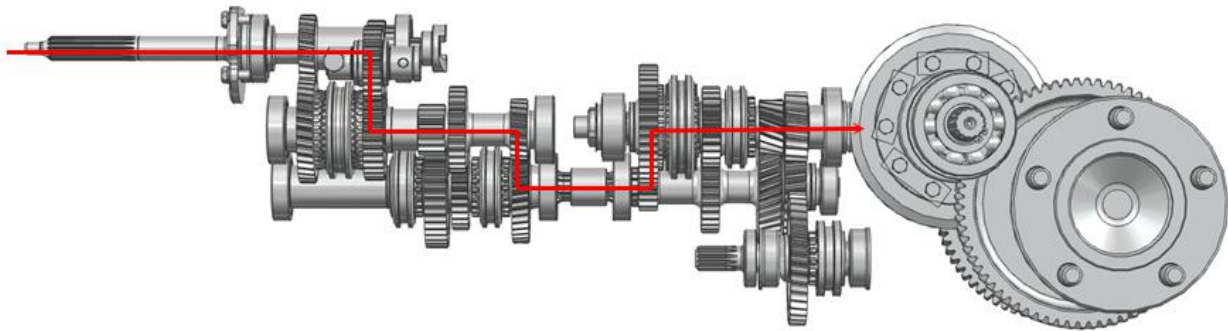

3. RL3 POWER FLOW:-

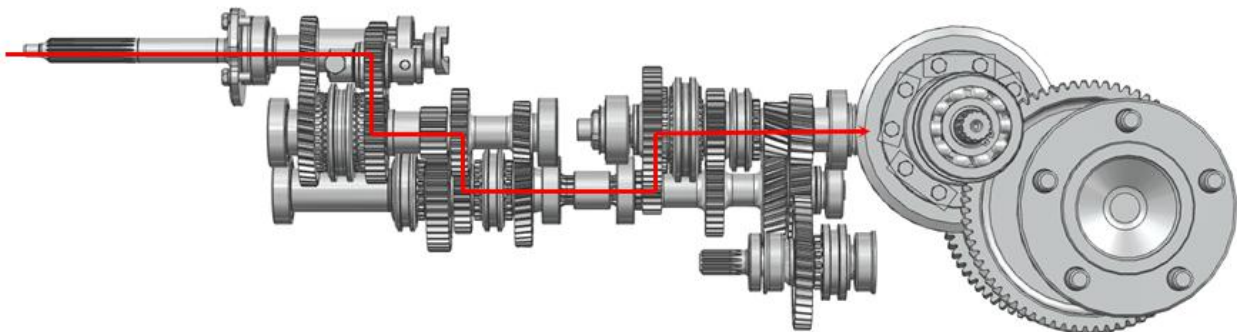

D.1 9+9 Power Flow Chart

1. RH1 POWER FLOW:-

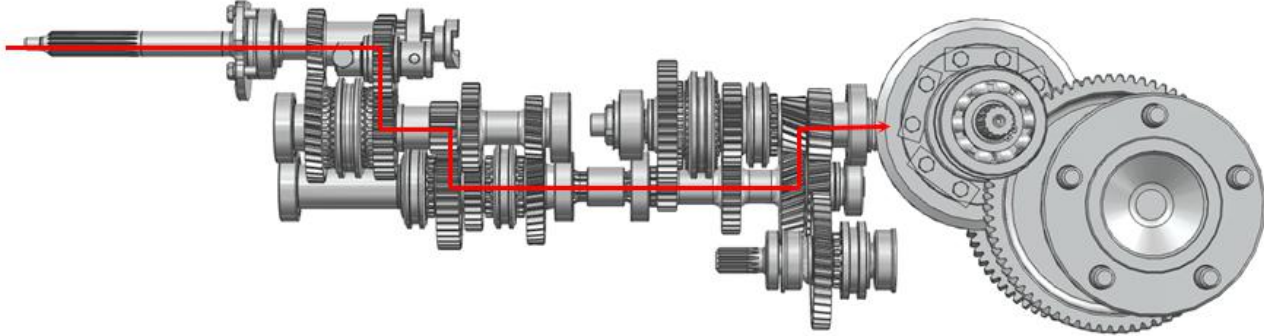

2. RH2 POWER FLOW:-

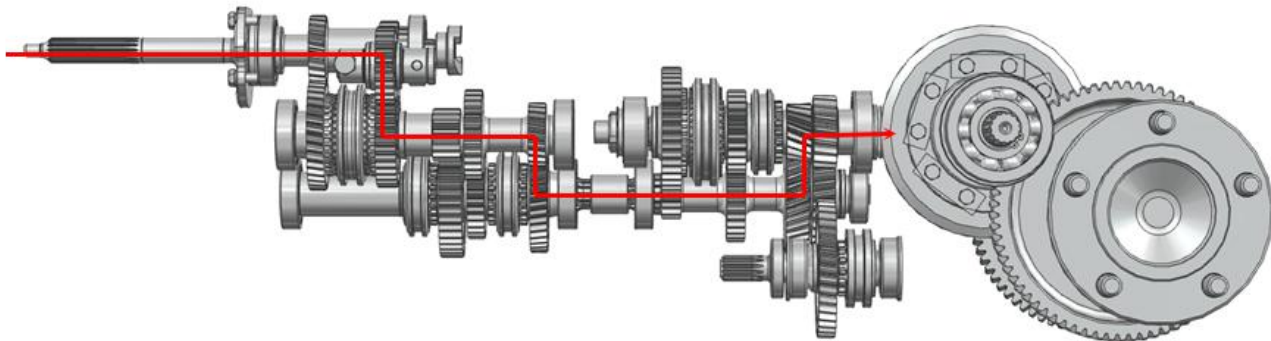

3. RH3 POWER FLOW:-

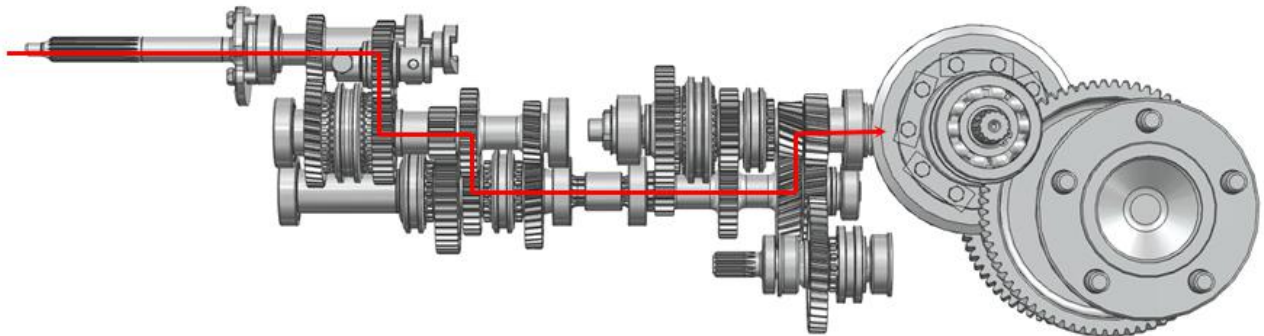

D.1 9+9 Power Flow Chart

1. PTO 540 :-



2. PTO 540E :-

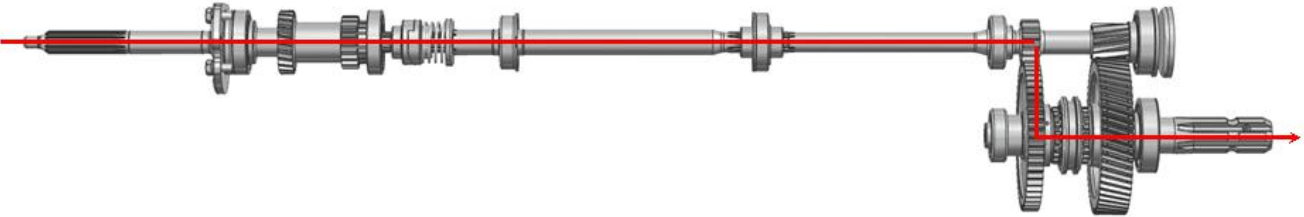

E.1 Filling and Checks

To drain and load the oil and to check the oil level the transmission must be horizontal.

Scheduled maintenance oil drain.

To drain the oil remove the level filler and the drain plug .

E.1.a Fill Transmission Oil:

Fill the transmission with oil to the maximum level marked on the level dipstick

Apply the parking brake.

Keep the speed control in NEUTRAL range.

Start the engine at idle RPM until oil circulate in system.

Keep the Hydraulic Levers in Neutral Position. Shut off the Engine

Check that the transmission oil level is in the prescribed range on the level dipstick.

If necessary, top up with oil to keep the level in the prescribed range.

Scheduled maintenance oil check.





F.1 Service Schedule

Specified maintenance intervals are for standard-duty use.

Severe operating conditions may require more short intervals.

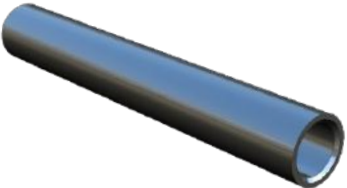
Recommended intervals									Operation
50 h	250 h	500 h	750 h	1000 h	1250 h	1500 h	1750 h	2000 h	
				●				●	Change the transmission/hydraulic oil
			●			●			Change the oil suction strainer
●	●	●	●	●	●	●	●	●	Clean the Transmission Breather Assy

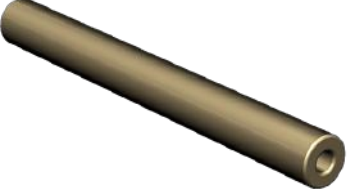
G.1 Special Service Tool

Sr. No.	Part NO.	Description	Purpose	Picture
1.	9+9 001	Mandrel	Pressing Taper Roller Bearing of Tail Pinion.	
2.	9+9 002	Mandrel	Pressing Dowel Pin DIA 10*45.	
3.	9+9 003	Mandrel	Pressing Cotter Sleeve DIA 6	
4.	9+9 004	Guiding Sleeve	4WD Oil Seal fitment	

G.1 Special Service Tool

Sr. No.	Part NO.	Description	Purpose	Picture
5.	9+9 005	Mandrel	Pressing Ball Bearing BB 1063 in Intermediate Shaft	
6.	9+9 006	Mandrel	Pressing Ball Bearing 6305 in Lay Shaft	
7.	9+9 007	Mandrel	Pressing Ball Bearing BB1063 in Clutch Housing	
8.	9+9 008	Mandrel	Pressing Oil Seal in Clutch Housing	

G.1 Special Service Tool

Sr. No.	Part NO.	Description	Purpose	Picture
9.	9+9 009	Mandrel	Pressing Cap in Clutch Housing	
10.	9+9 010	Mandrel	Pressing Cap in Clutch Housing	
11.	9+9 011	Mandrel	Pressing Ball Bearing 6007 in Clutch Housing	
12.	9+9 012	Mandrel	Pressing Ball Bearing 6307 in Clutch Housing	

G.1 Special Service Tool

Sr. No.	Part NO.	Description	Purpose	Picture
13.	18ME251	Mandrel	Pressing Oil Seal 25X52X10 of 4WD Output Shaft	
14.	18ME248	Mandrel	Pressing Ball Bearing 6406 in Rear Axle Bull Pinion Shaft.	
15.	18ME249	Mandrel	Pressing Ball Bearing 6304 on Lay Shaft.	
16.	18ME244	Mandrel	Pressing Ball Bearing 6205 in Transmission Housing of Rear PTO Output Shaft	

G.1 Special Service Tool

Sr. No.	Part NO.	Description	Purpose	Picture
17.	18ME237	Mandrel	Pressing Ball Bearing 6205 in Transmission of PTO Intermediate Shaft	
18.	18ME252	Mandrel	Pressing Oil Seal 50X68X10 in Rear Axle Housing fitment of Rear Axle Shaft	
19.	18ME235	Mandrel	Tool for tightening Withdrawal Nut	
20.	17ME113	Mandrel	Pressing Ball Bearing 6011 in Differential Cage.	

G.1 Special Service Tool

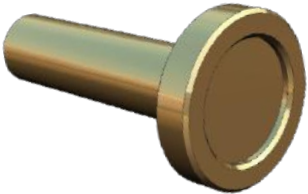
Sr. No.	Part NO.	Description	Purpose	Picture
21.	17ME111	Mandrel	Pressing Ball Bearing 6211 in Differential Cage.	

Gear Box Assembly

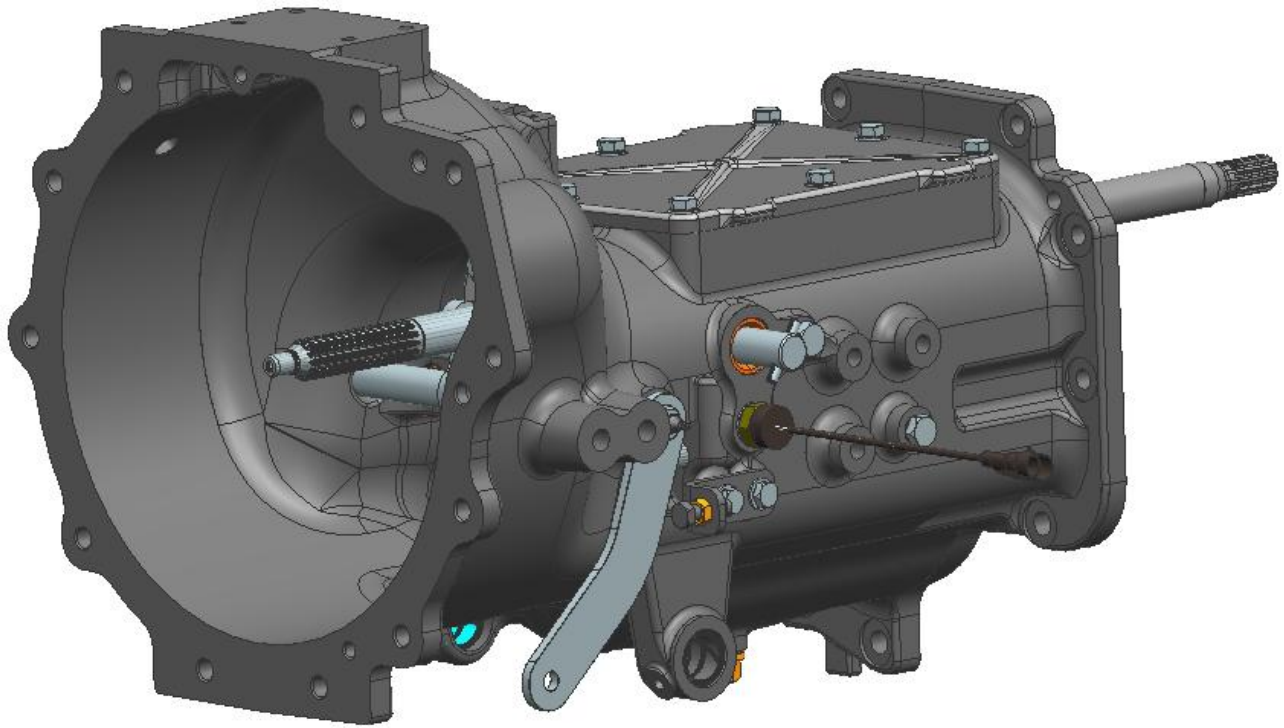

Disassembly of Gear Box

CONTENTS

REF. NO	DESCRIPTION	PAGE
A2	Disassembly of Gear Box	21-27
B2	Disassembly of Lay Shaft	28-30
C.2	Disassembly of Intermediate Shaft	31-32

A.2 Disassembly Gear Box Assembly

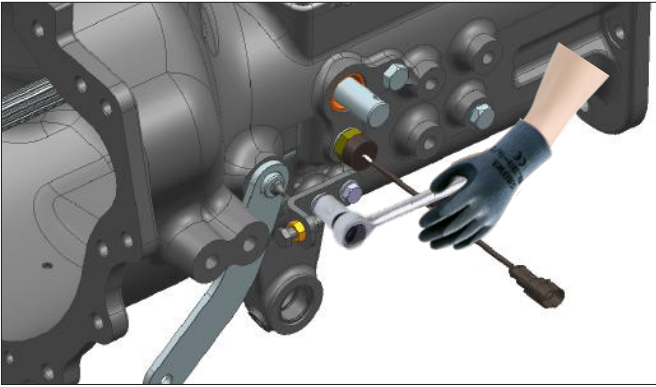

1.Remove the bolts of clutch stopper bracket.

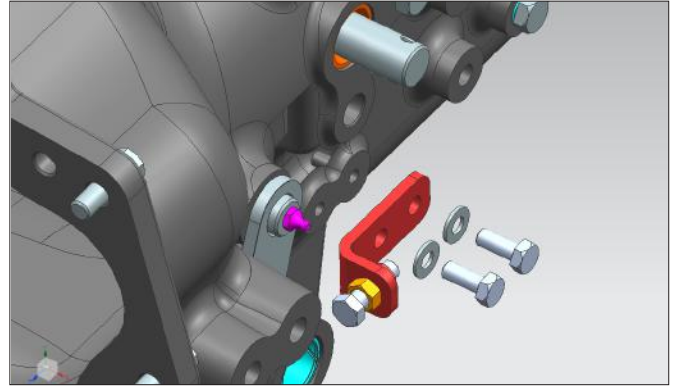

2.Remove the clutch stopper bracket.

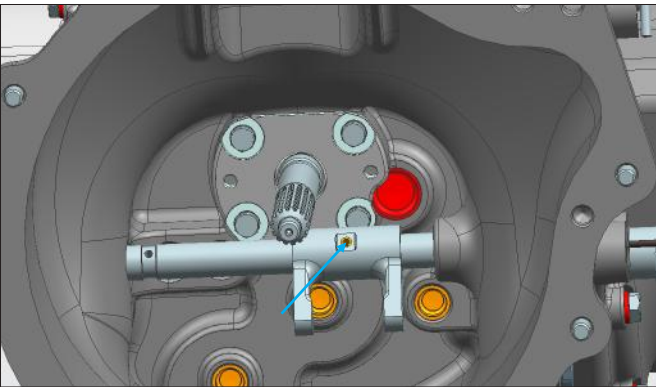

3.Slightly pull and rotate clutch lever to anticlockwise to give the position to CRB fork as per Fig.

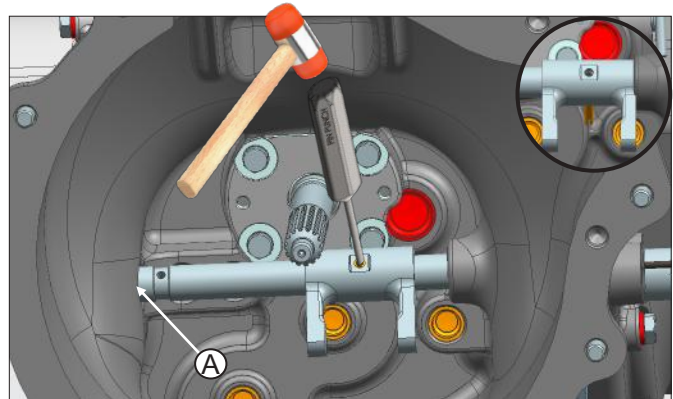

4.Remove the cotter sleeve of fork clutch.

Note:- Shaft end (A) should be rest inside the housing.

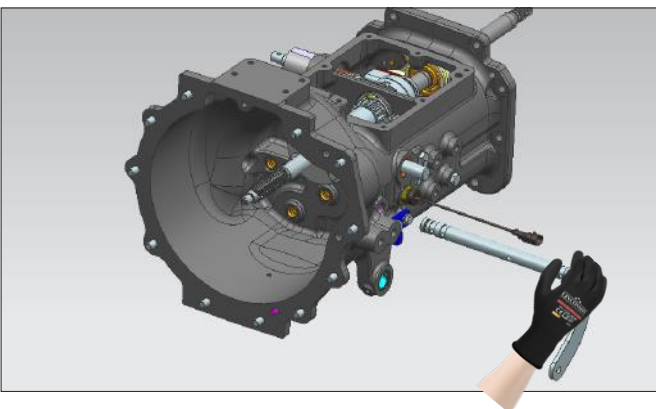

5.Remove the clutch lever shaft and CRB fork.

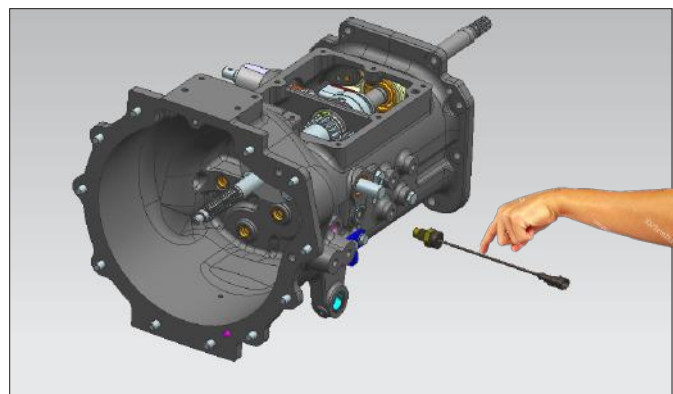

6.Remove the neutral switch.

A.2 Disassembly Gear Box Assembly

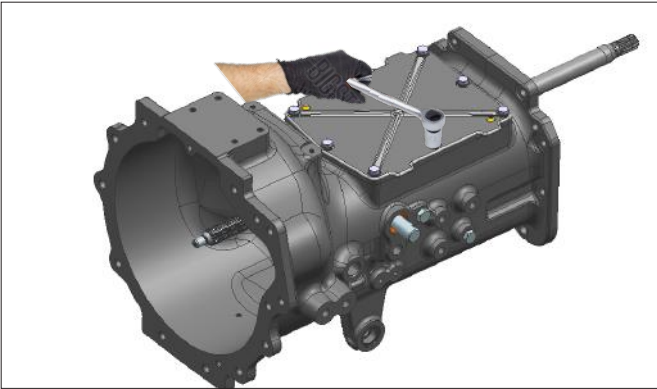

7.Remove the bolts of clutch top cover.

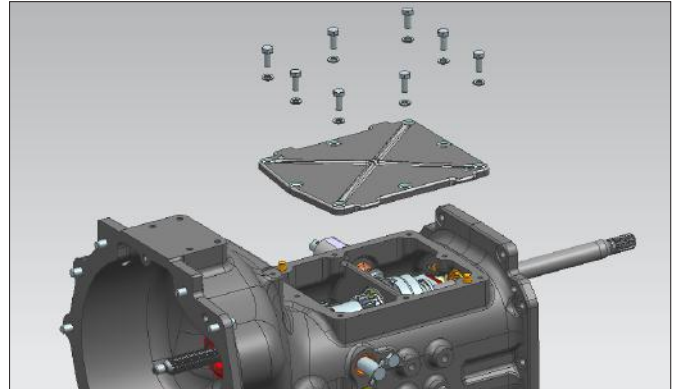

8.Remove the clutch top cover.

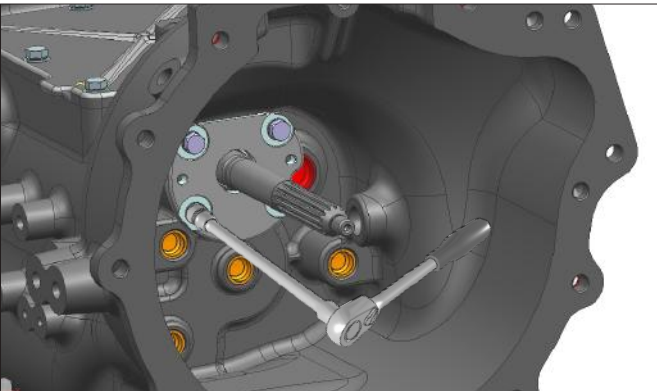

9.Remove the bolts of input shaft retainer.

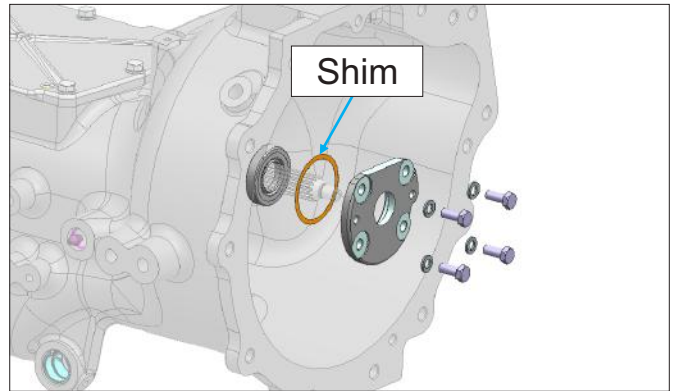

10.Remove the input shaft retainer and shim.
Tie the shim with retainer plate.

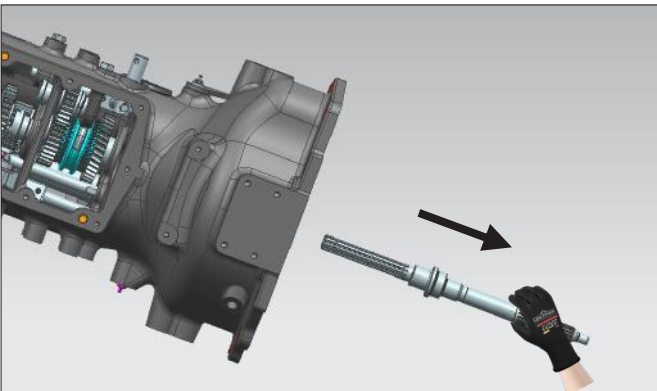

11.Slightly strike with hammer at rear end of input shaft. Pull out the input shaft from front.

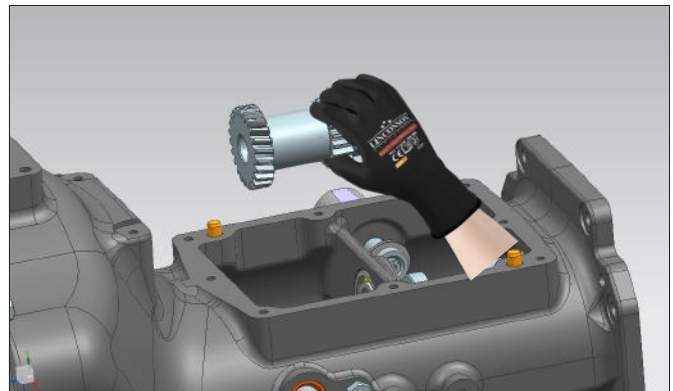

12.Remove the shuttle gear.

A.2 Disassembly Gear Box Assembly

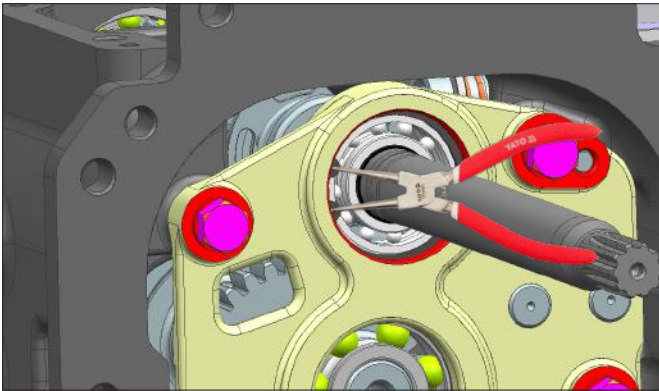

13.Remove the circlip of PTO coupler shaft assembly.

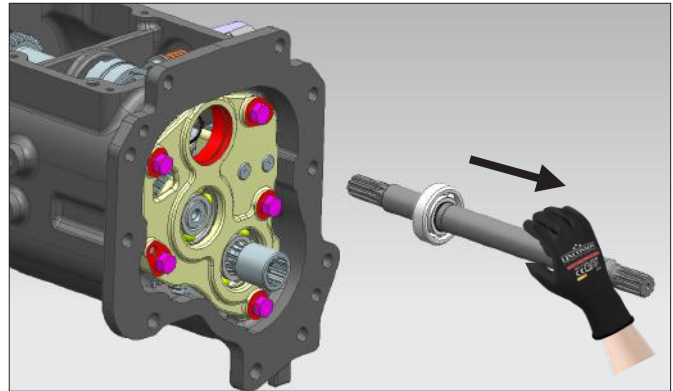

14.Pull out the PTO clutch shaft.

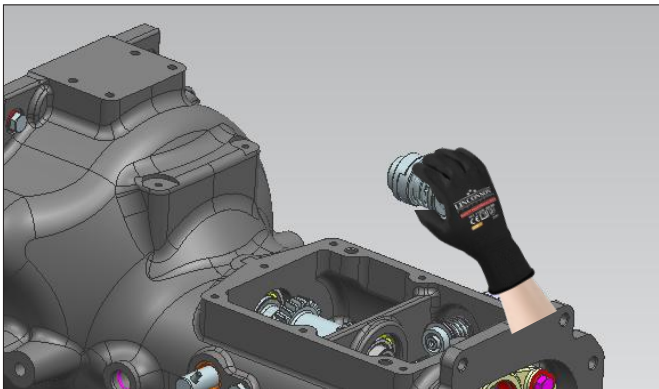

15.Remove the PTO slip clutch assembly.

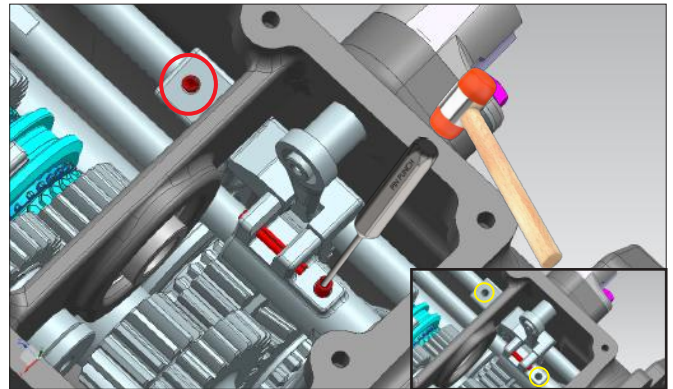

16.Remove the cotter sleeve of fork 2ND-3RD and fork 1ST gear.

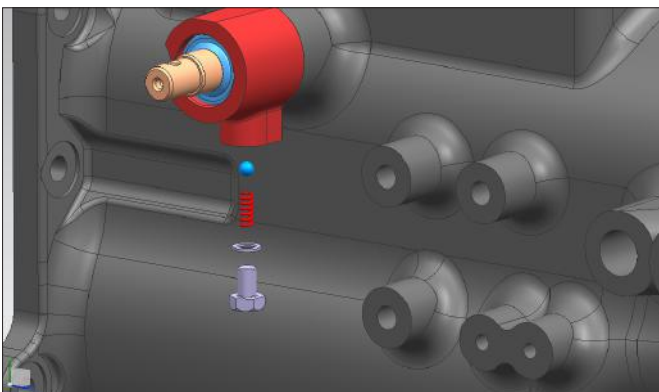

17.Remove the bolt and remove spring and ball. Tie the ball spring with mounting hub.

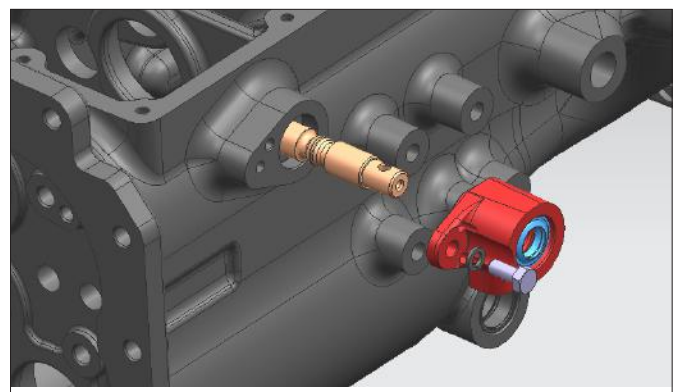

18.Unscrew the bolts of mounting hub and remove the hub.

A.2 Disassembly Gear Box Assembly

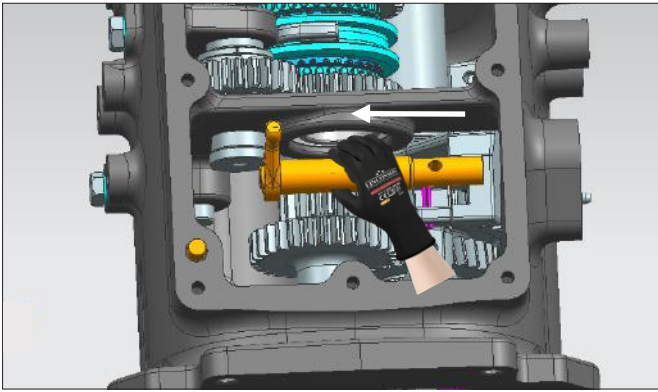

19.Remove the pivot lug.

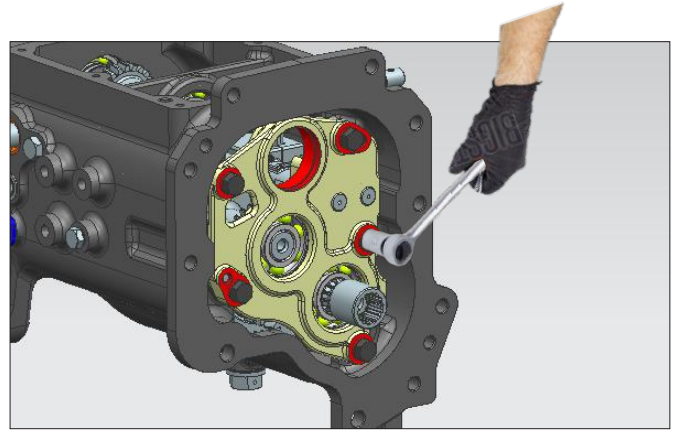

20.Remove the bolts of bearing holder plate.

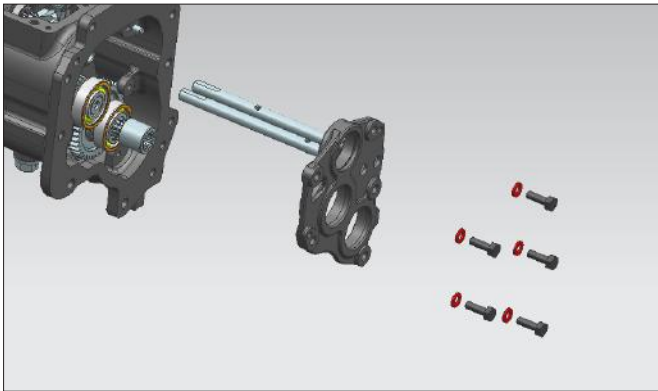

21.Remove the bearing holder plate.

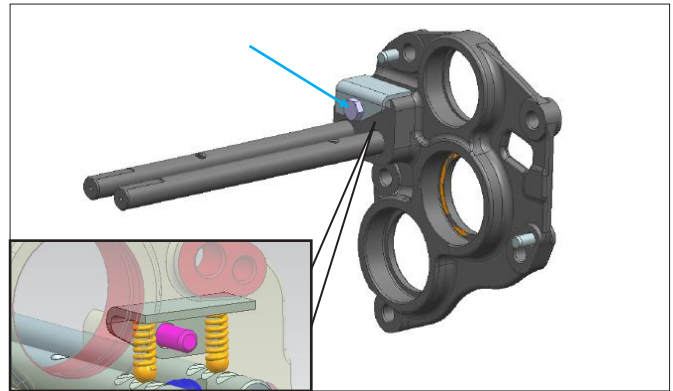

22.Remove the bolt of bearing holder plate and remove the ball and spring.

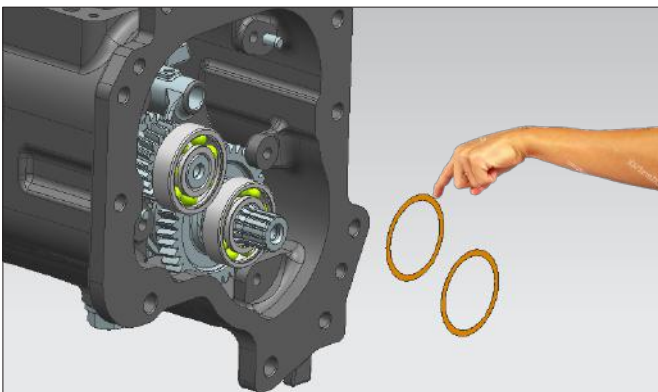

23.Remove the shims of intermediate shaft and lay shaft. Tie the shims of intermediate and lay shaft with intermediate plate at their appropriate location.
Note-Do not interchange the shims of lay and intermediate Shaft.

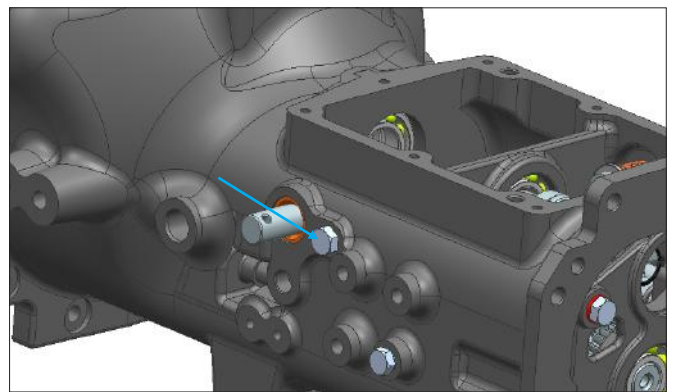

24.Remove the bolt of idle gear shaft reverse.

A.2 Disassembly Gear Box Assembly

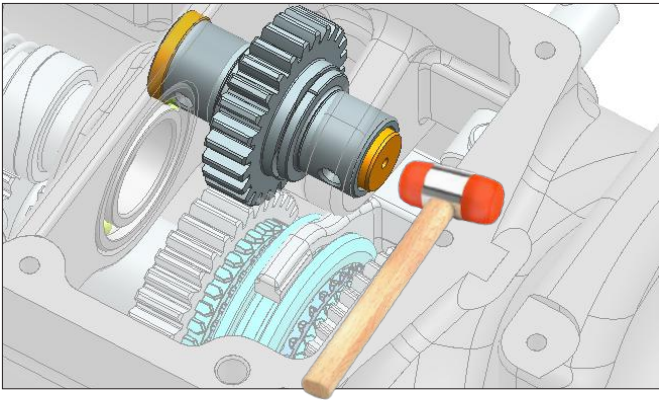

25. Slightly strike on front end of the Gear Shaft Reverse.

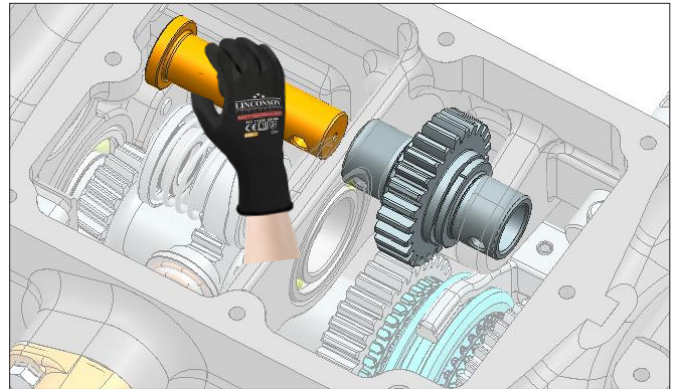

26. Remove the idle gear shaft reverse.

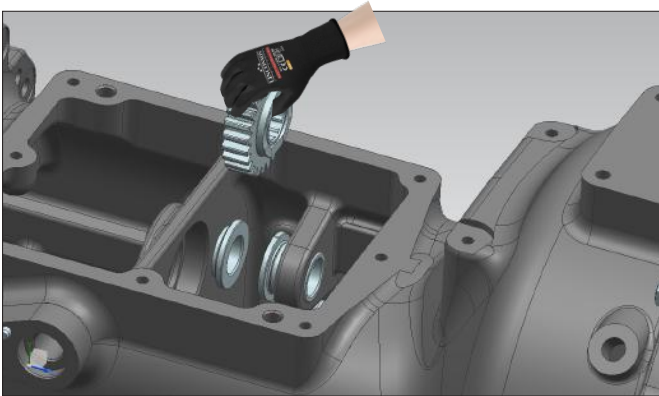

27. Remove the idle gear.

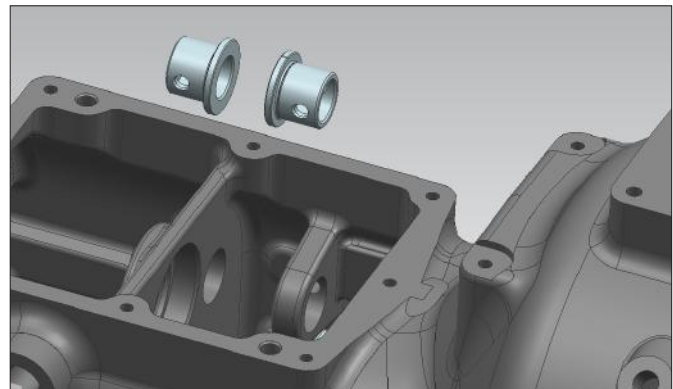

28. Remove the spacers.

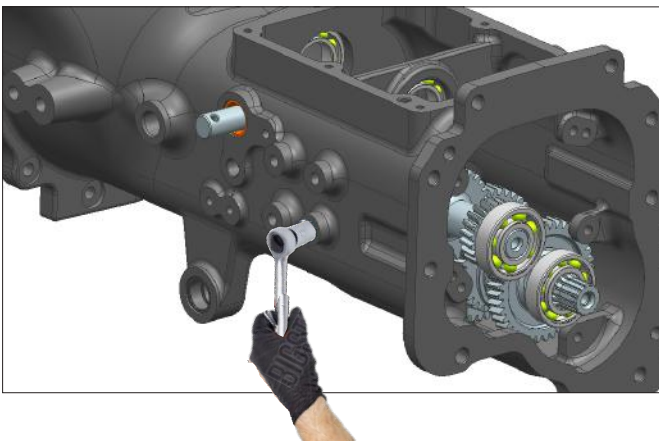

29. Remove the bolt of shuttle shifter rod.

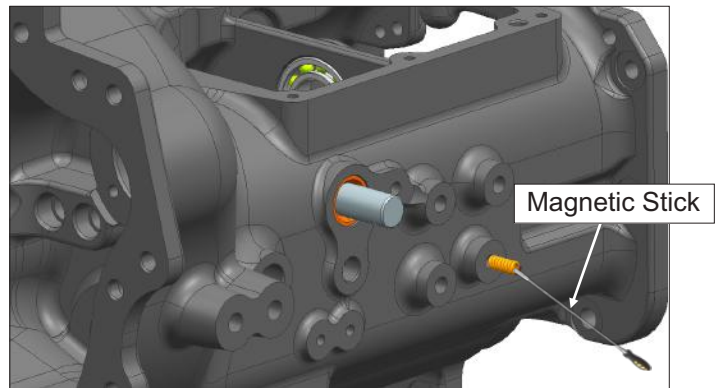

30. Remove the spring using of magnetic stick.

A.2 Disassembly Gear Box Assembly

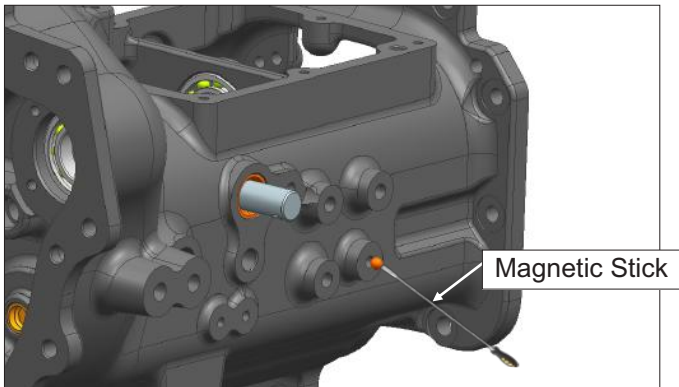

31. Remove the ball using of magnetic stick.

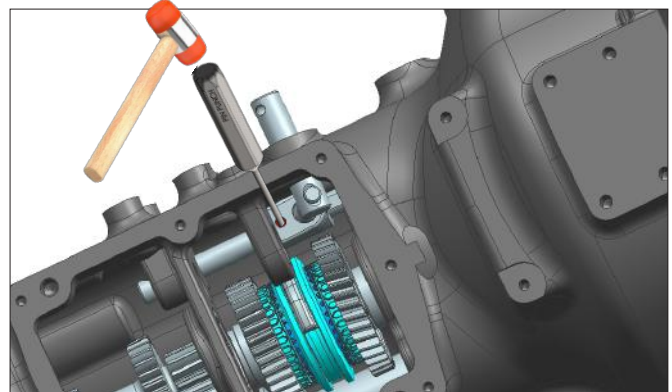

32. Remove the cotter sleeve of shuttle fork.

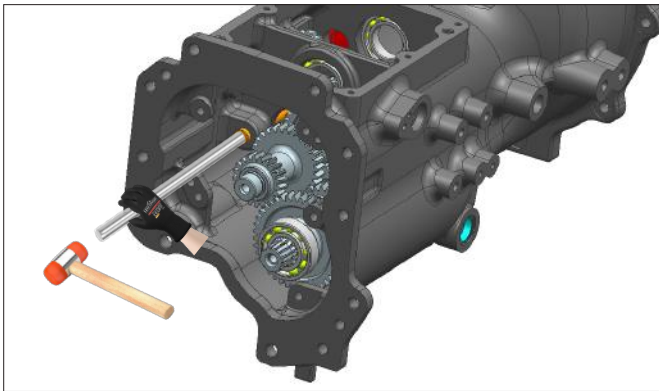

33. Slightly strike at rear end of shifter rod by using bar and hammer.

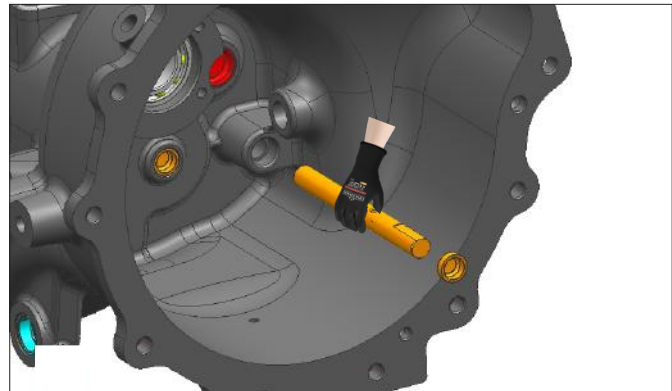

34. Remove the shifter rod from front.

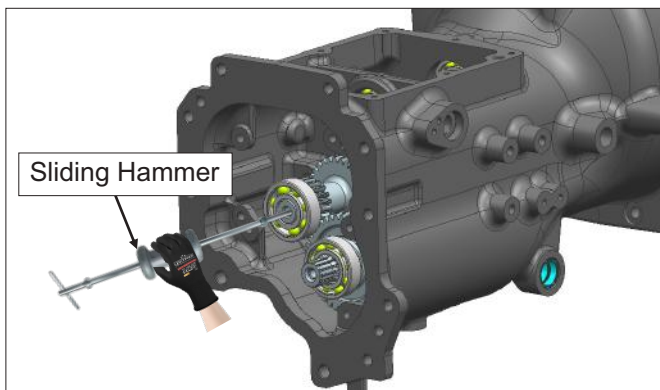

35. Hold the synchronizer unit and remove the intermediate shaft assembly by using sliding hammer.

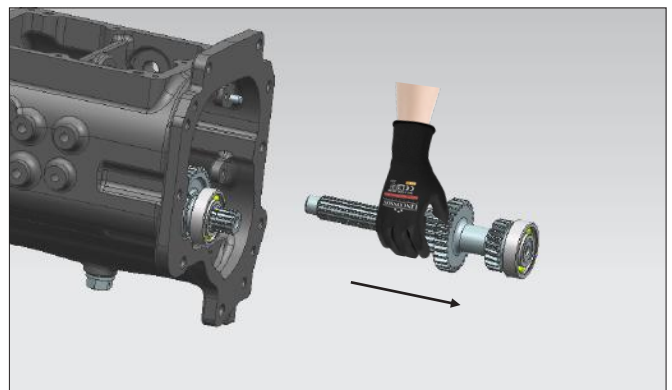

A.2 Disassembly Gear Box Assembly

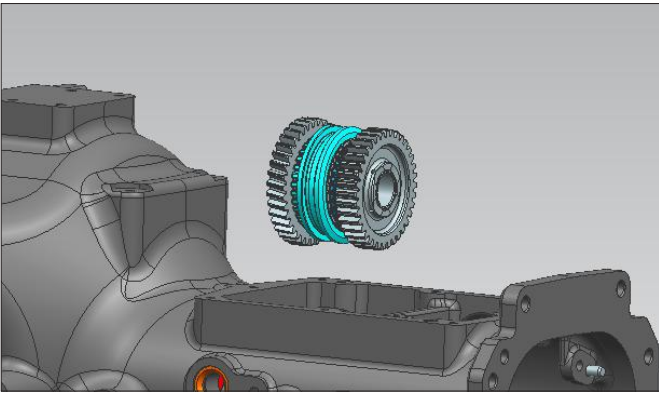

36.Remove the shuttle gears and synchro assembly.

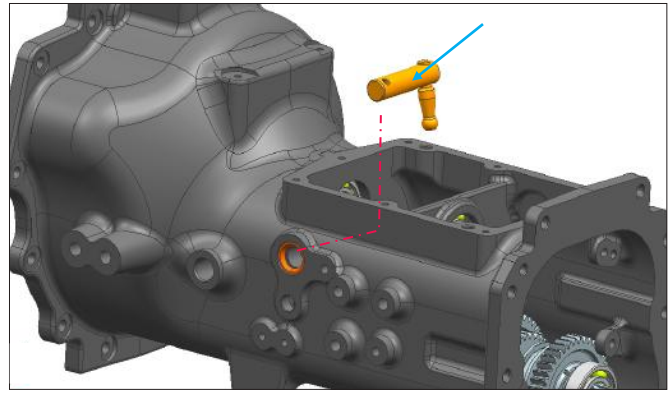

37.Remove the shuttle fork lever.

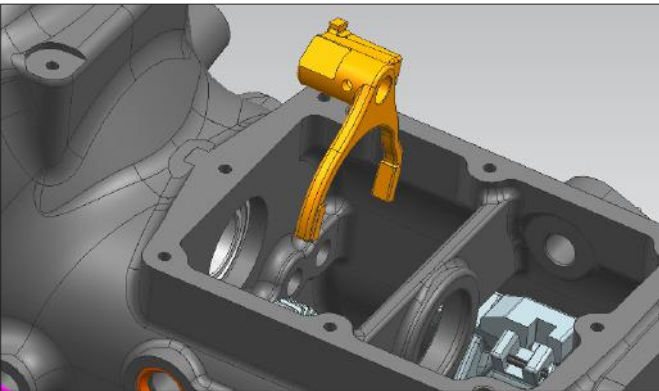

38.Remove the shuttle fork.

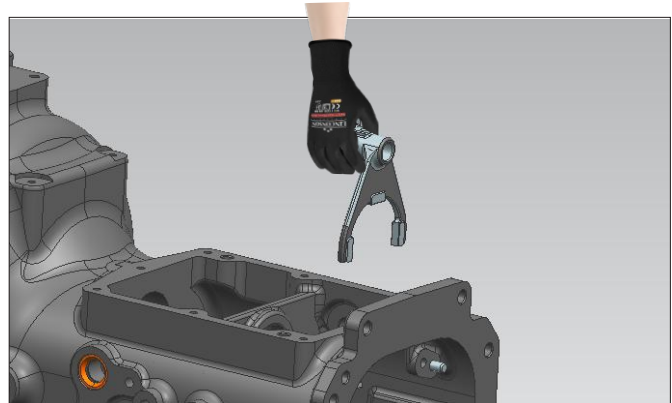

39.Remove the shifter fork 2nd-3rd gear.

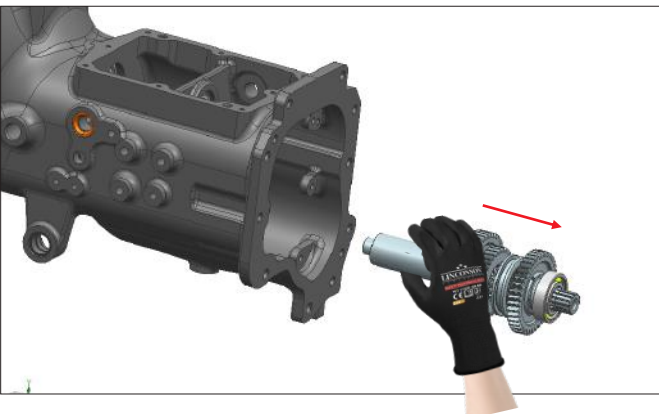

40.Remove the lay shaft sub assembly by using sliding hammer.

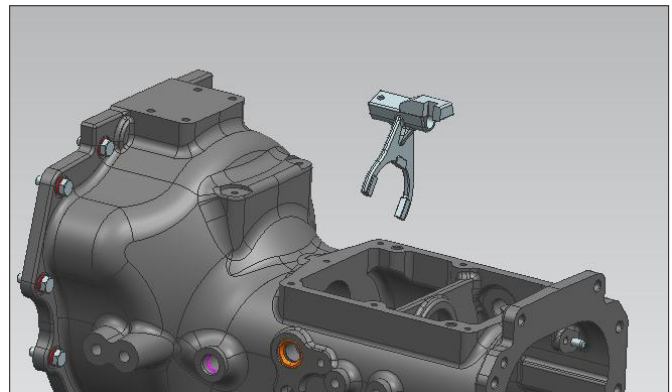

41.Remove the shifter fork 1st gear.

B.2 Disassembly of Lay Shaft Assembly

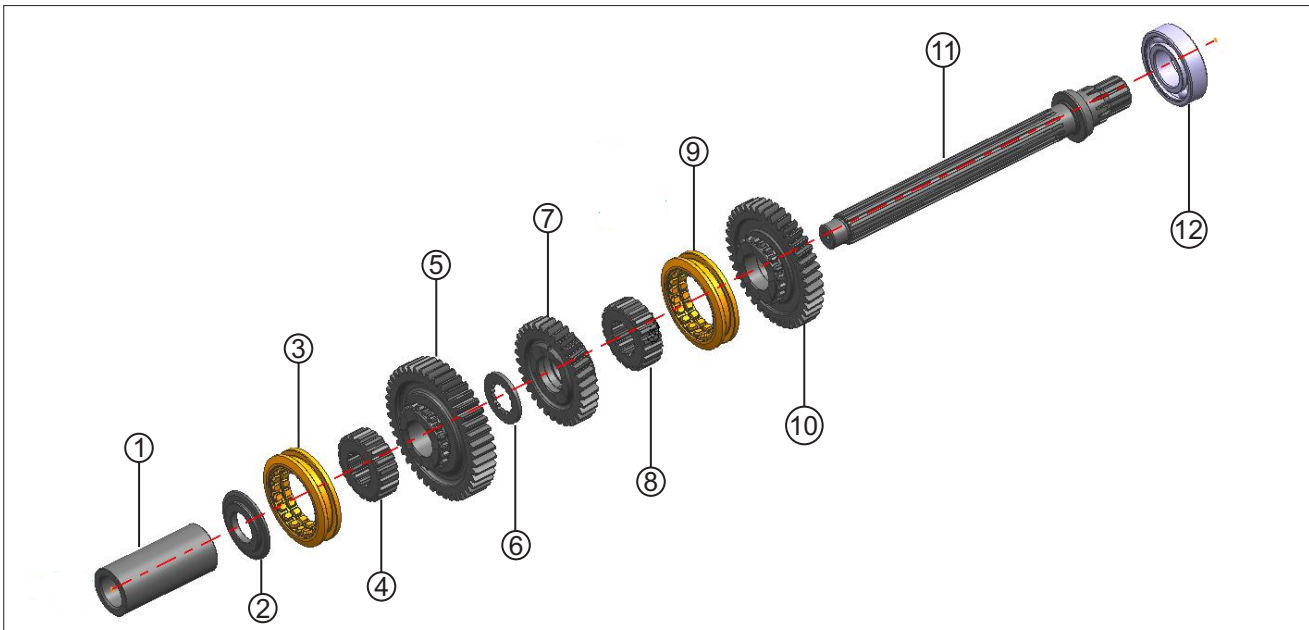
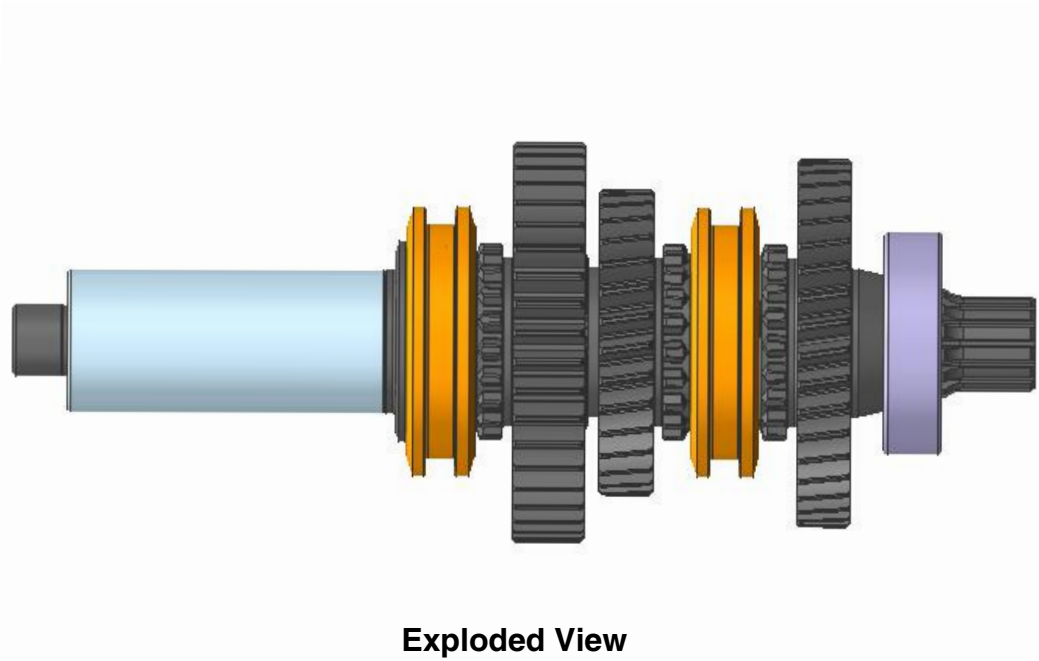

1	Spacer for Dog Clutch Gear
2	Spacer
3	Shifter Sleeve
4	Hub
5	1ST Gear Dog Z-35
6	Thrust Washer
7	3RD Gear Dog

8	Hub
9	Shifter Sleeve
10	2ND Dog Gear
11	Lay Shaft
12	Ball Bearing 6206

B.2 Disassembly of Lay Shaft Assembly

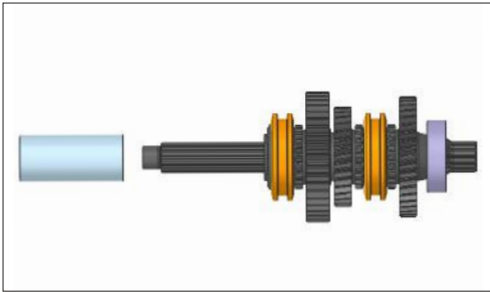

a.Remove the Spacer for Dog Clutch Gear.

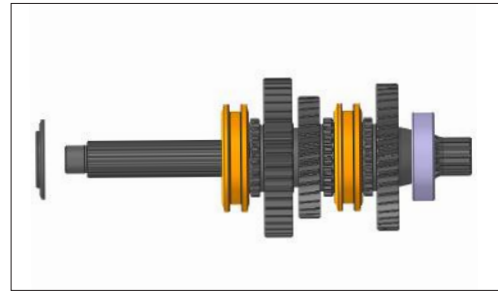

b.Remove the Spacer.

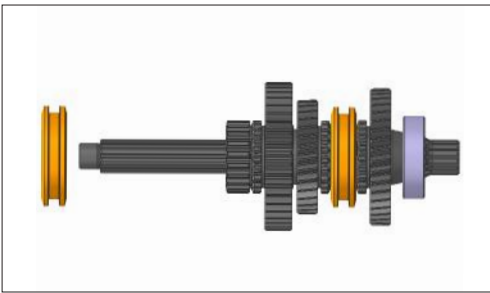

c.Remove the shifter sleeve.

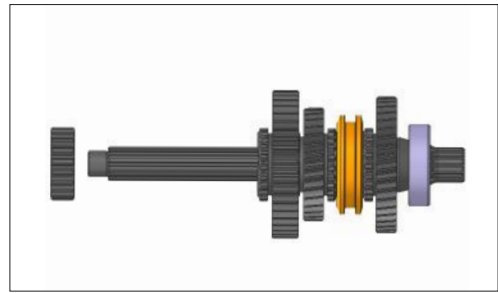

d.Remove the hub.

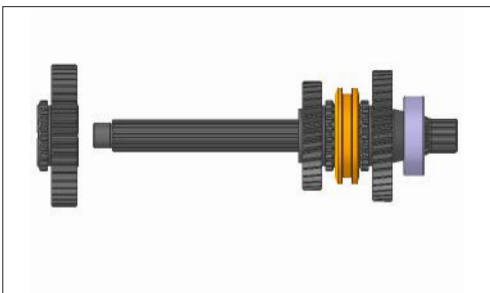

e.Remove the 1ST gear.

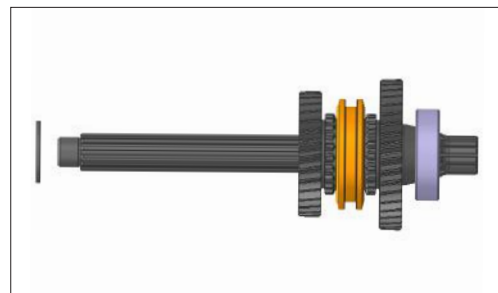

f.Remove the thrust washer.

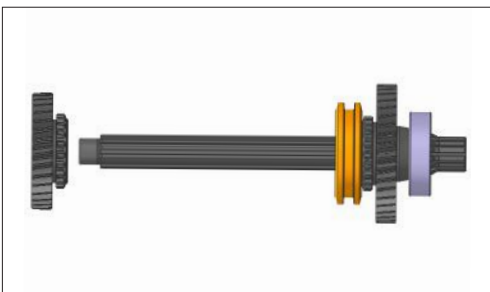

g.Remove the 3RD dog gear.

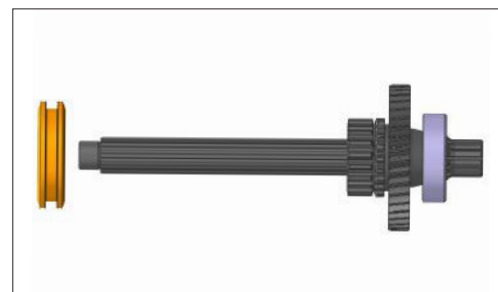

h.Remove the shifter sleeve.

B.2 Disassembly of Lay Shaft Assembly

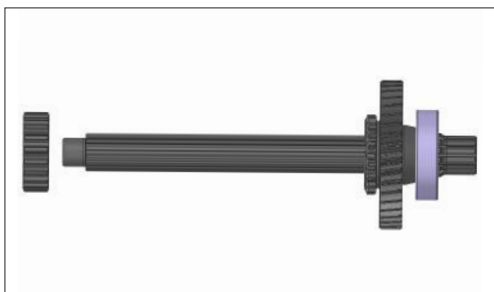

i.Remove the hub.

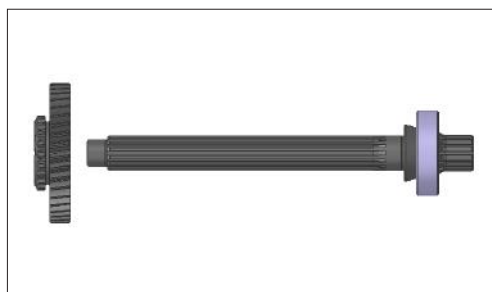

j.Remove the 2ND gear.



k.Remove the lay shaft bearing by using bearing puller.

C.2 Disassembly of Intermediate Shaft Assembly

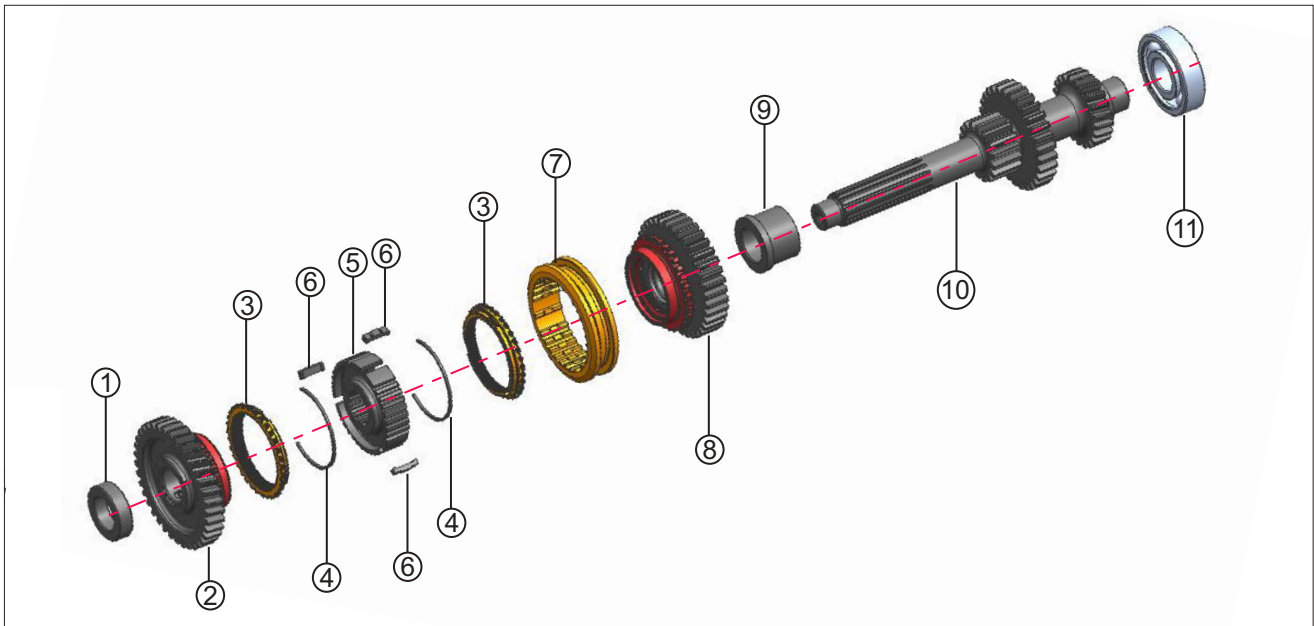
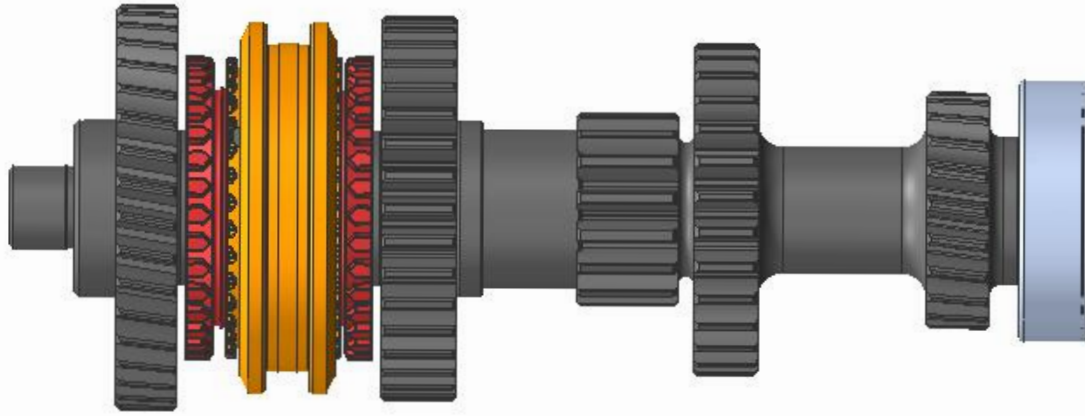

1	Spacer
2	Shuttle Gear Forward
3	Synchro Cone
4	Carrier Spring
5	Hub Synchro
6	Sturt
7	Sleeve Synchro

8	Shuttle Gear Reverse
9	Spacer
10	Intermediate Shaft
11	Ball Bearing 6305

C.2 Disassembly of Intermediate Shaft Assembly

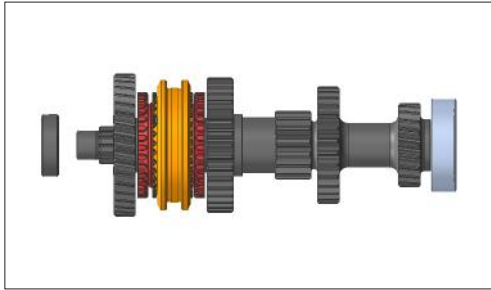

a.Remove the spacer of FWD gear.



b.Remove the forward shuttle gear.

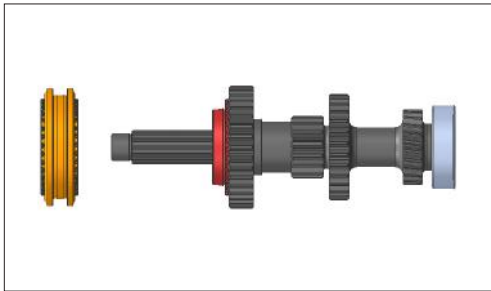

c.Remove the sleeve and synchro assembly.



d.Remove the reverse shuttle gear.

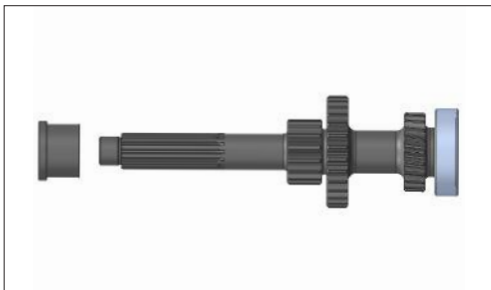

e.Remove the spacer.

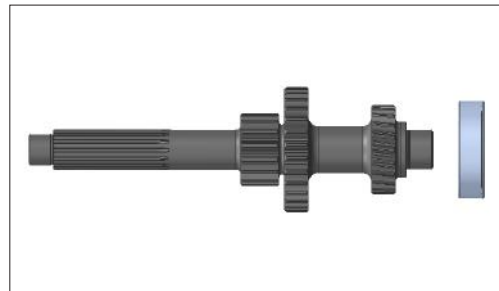

f.Remove the intermediate shaft bearing by using bearing puller.

Differential and Rear Axle Assembly

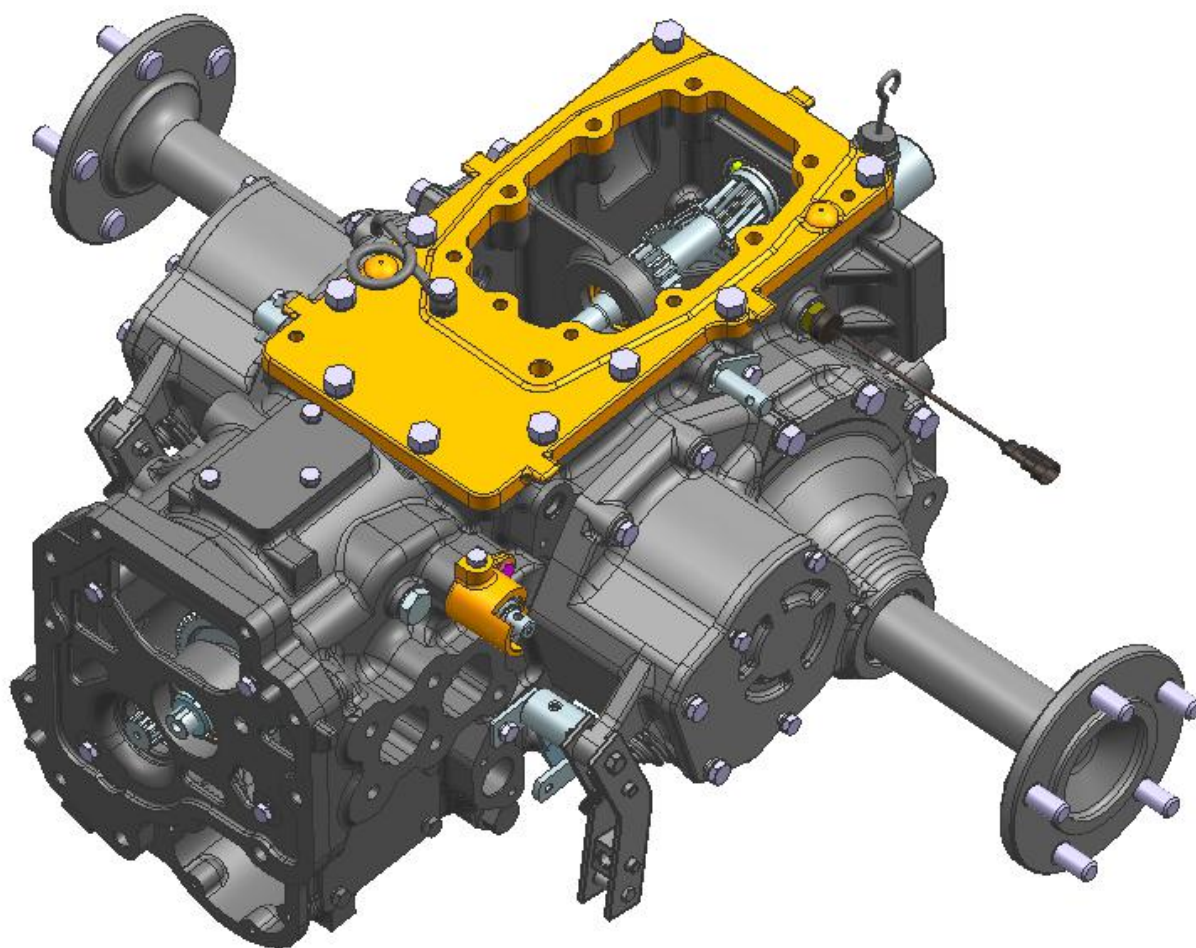

Disassembly of Differential & Trumpet Housing

CONTENTS

REF. NO	DESCRIPTION	PAGE
A.3	Disassembly of Differential Housing	35-42
B.3	Disassembly of Trumpet Housing	43-44
C.3	Disassembly of Tail Pinion Shaft	45-47
D.3	Disassembly of Range Lay Shaft	48
E.3	Disassembly of Differential Sub Cage	49-51

A.3 Disassembly of Differential Housing

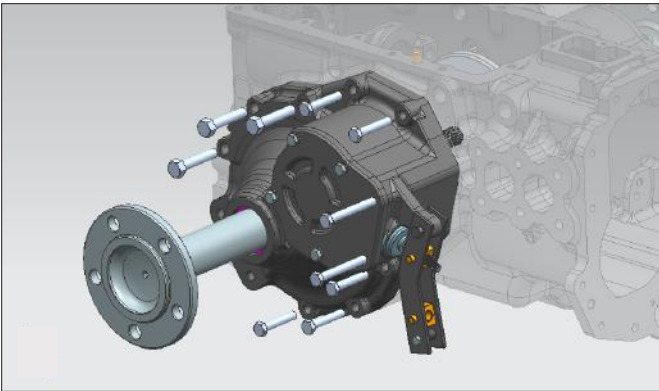

1.Remove the bolts of rear axle sub assembly.

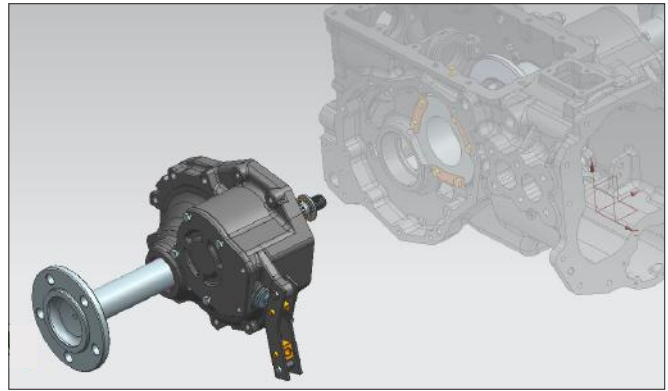

2.Remove the rear axle sub assembly.



3.Remove the bolts of intermediate plate for lift housing.

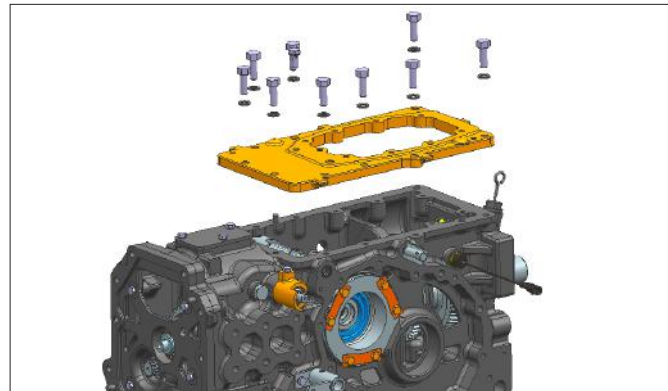

4.Remove the intermediate plate for lift housing.

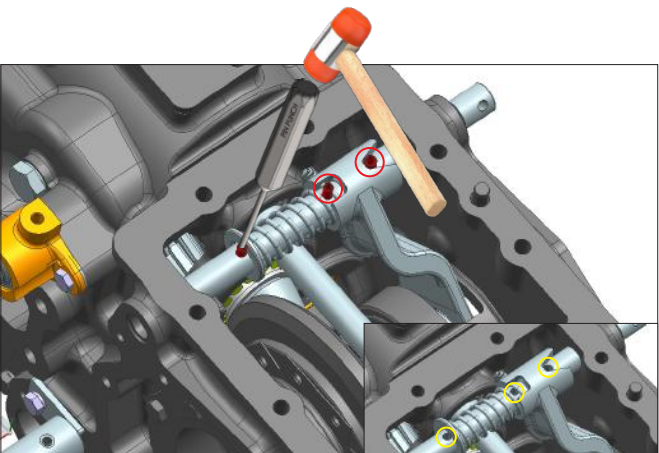

5.Remove the cotter sleeve of diff lock rod.

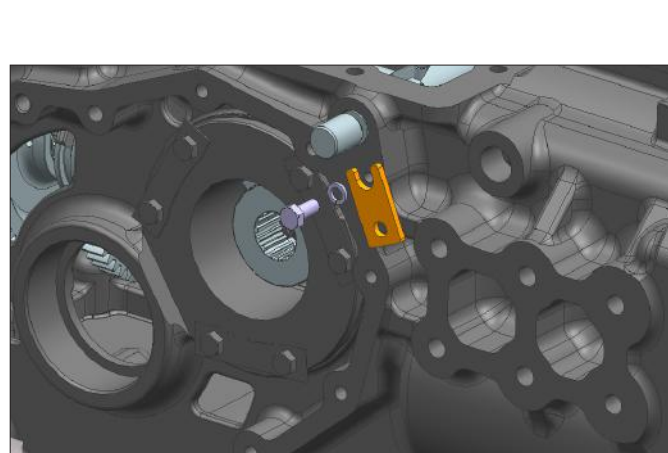

6.Remove the bolt and lock plate.

A.3 Disassembly of Differential Housing

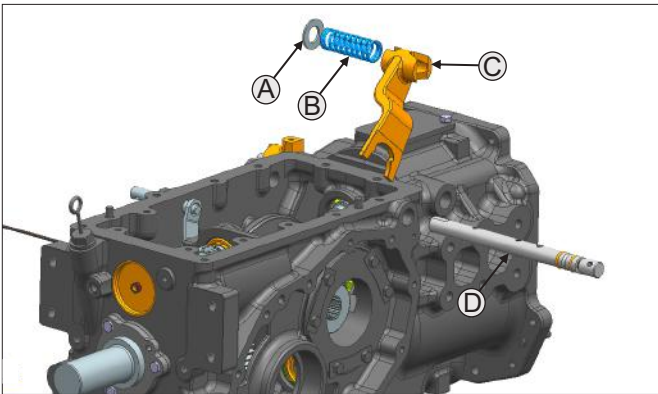

7. Remove the fork diff lock (C), spring (B), spacer (A) and pull out differential lock rod (D).

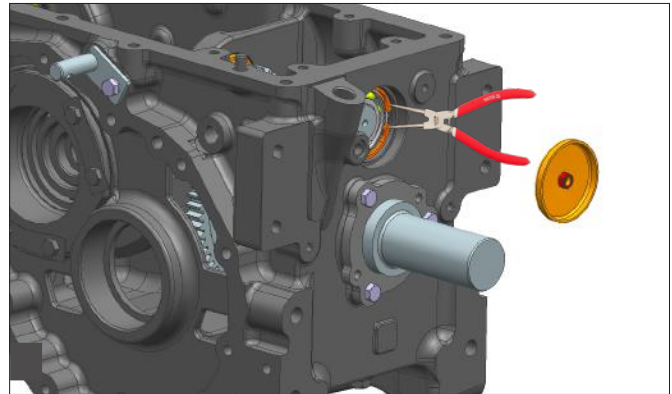

8. Tight the bolt in cap cover M8 and Pull out the cap cover. Remove the circlip of PTO intermediate shaft.

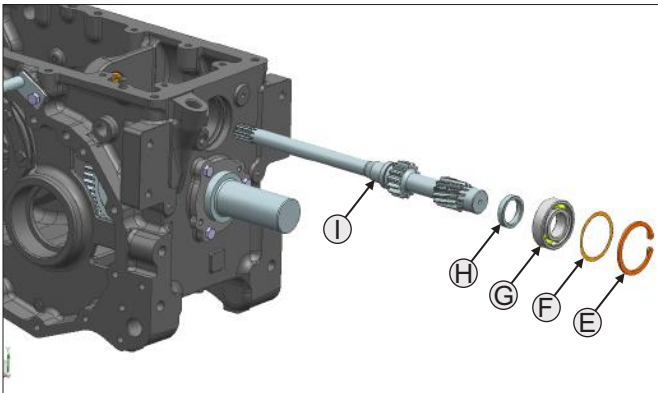

9. Remove the circlip (E), shim (F), bearing (G), spacer (H) and PTO intermediate shaft (I) and tie the shim with PTO intermediate shaft.

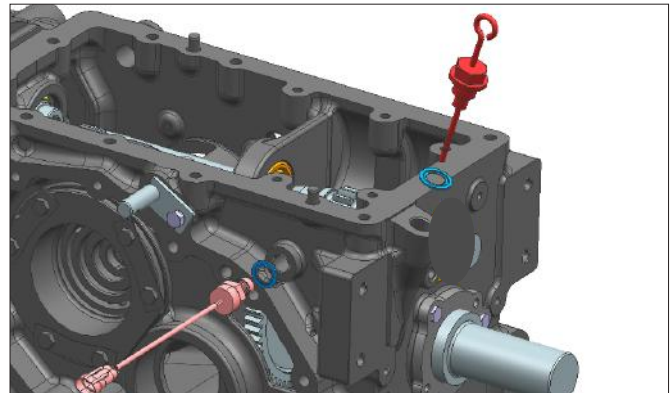

10. Remove the dipstick of transmission assembly. Unscrew and remove the PTO safety switch.

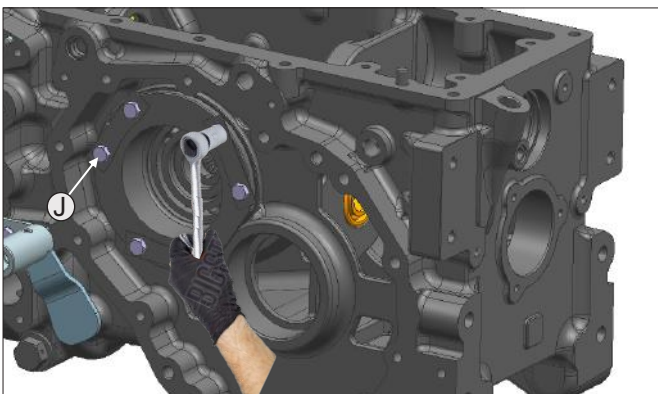

11. Remove the bolts (J) of carrier cage.

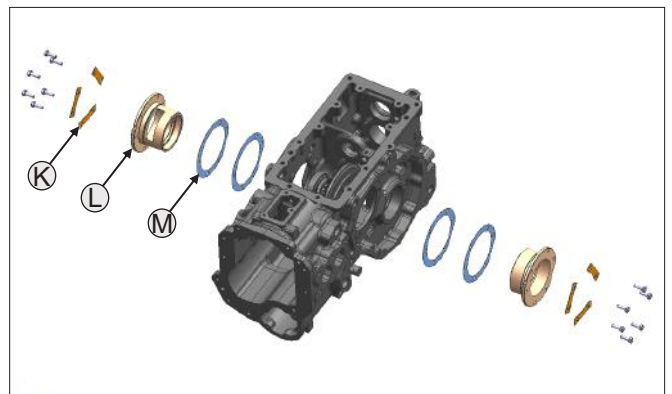

12. Remove the cage carrier (L) and locking washer (K). Tie the LH shims (M) with LH cage and RH shim with RH cage.

A.3 Disassembly of Differential Housing

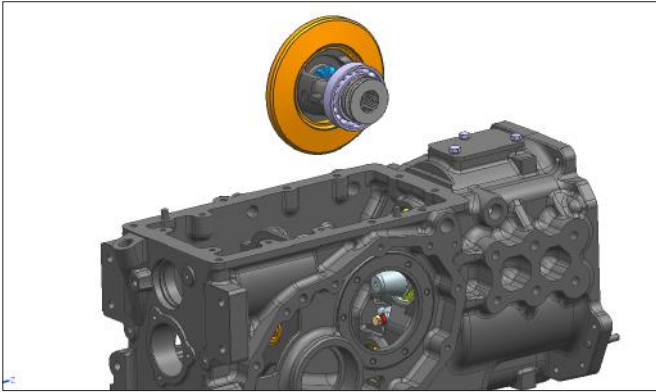

13. Remove the cage sub assembly.

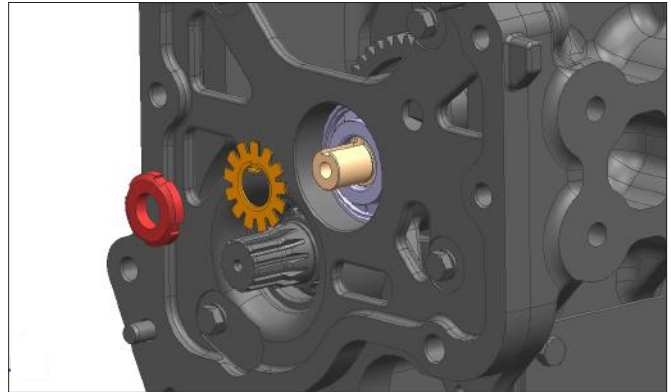

14. Unlock locking washer by using chisel and hammer. Remove the locking nut and washer of tail pinion shaft.

Note :- Replace the Locking Washer with new one during assembly.

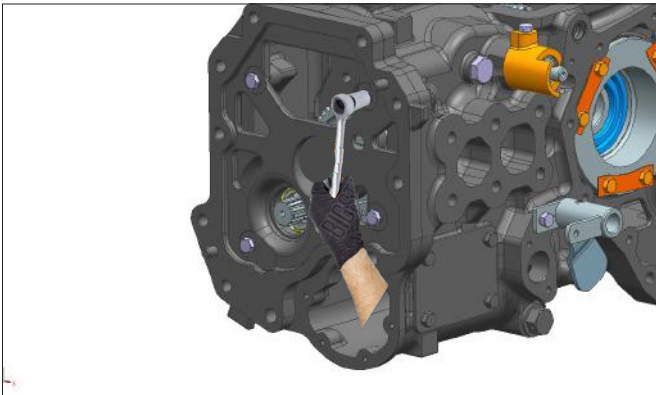

15. Remove the bolts of intermediate plate.

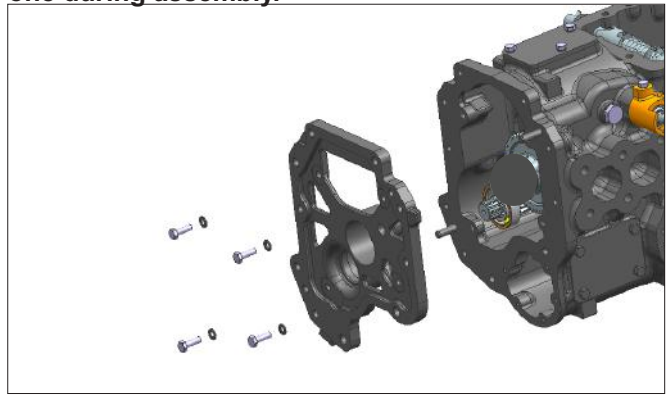

16. Remove the intermediate plate. Tie the range lay shaft shim with plate.

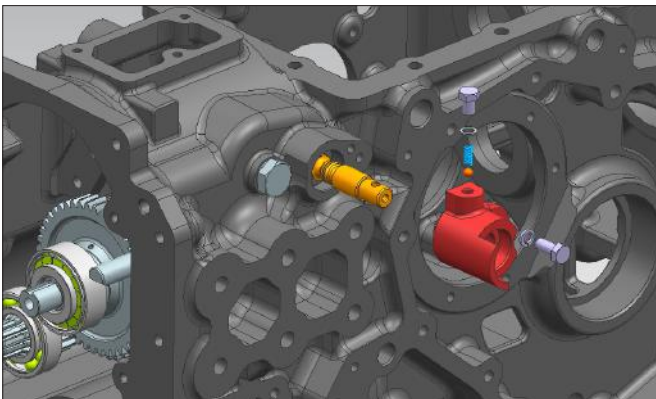

17. Remove the bolt, spring and ball. Tie the spring and ball with mounting hub.

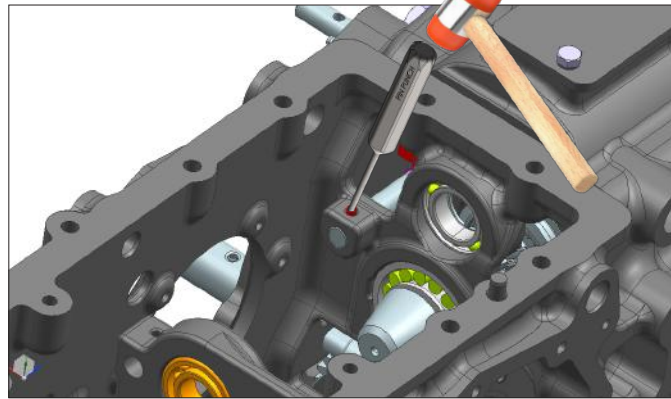

18. Remove the cotter sleeve of range shifter rod.

A.3 Disassembly of Differential Housing

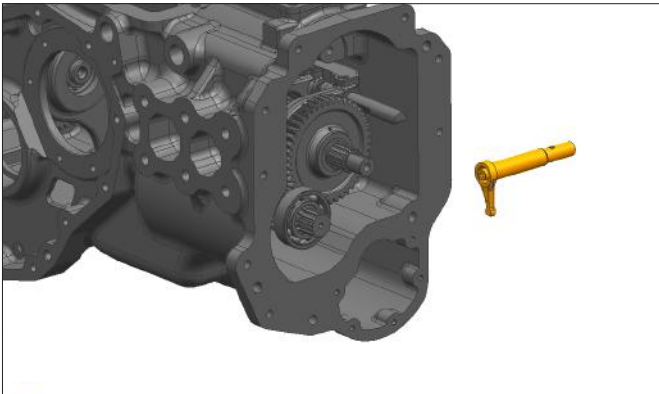

19. Remove the range pivot lug.

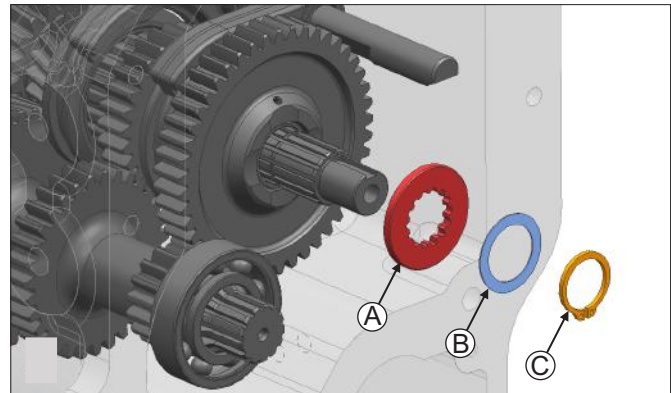

20. Remove locking washer (A), shim (B) and circlip (C).

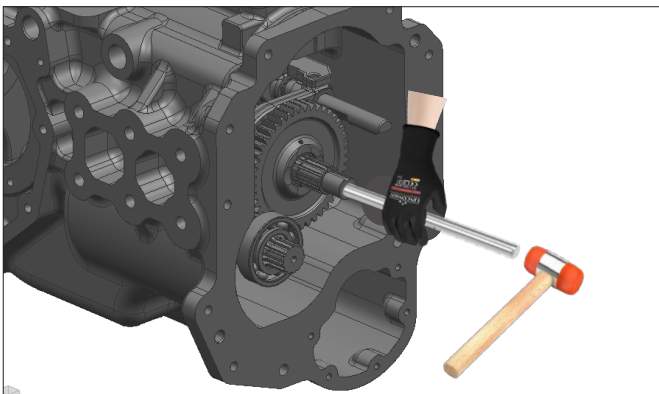

21. Slightly strike on rear end of tail pinion shaft by using soft bar and hammer.

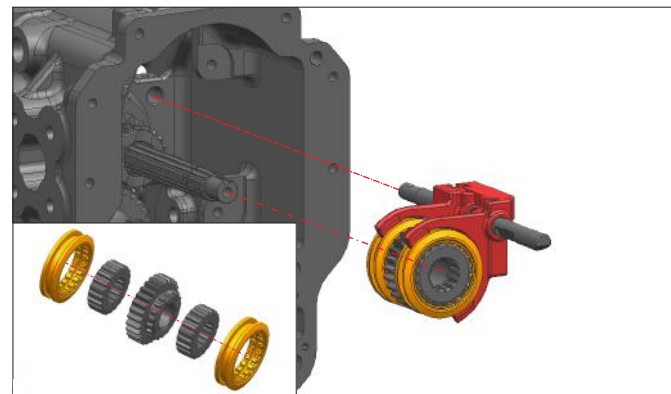

22. Remove the range fork assembly.

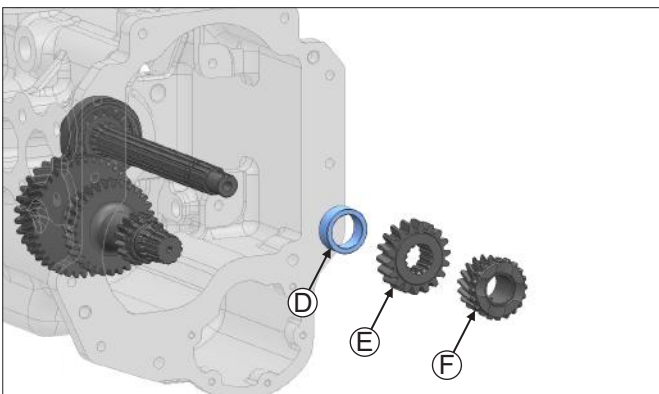

23. Remove high dog gear (F), driver gear 4WD (E) and spacer (D).

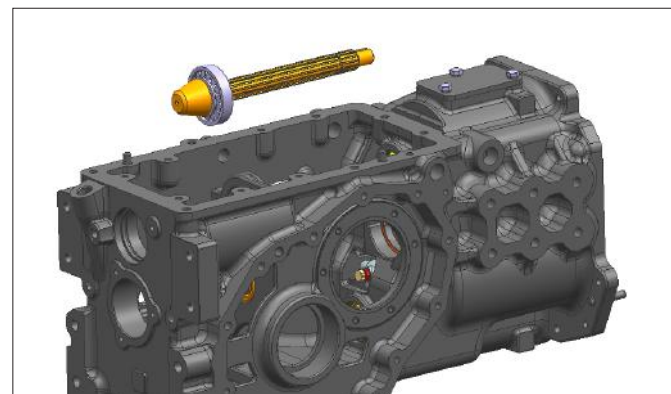

24. Remove the tail pinion and taper bearing outer cone. Tie the shim with outer cone.

A.3 Disassembly of Differential Housing

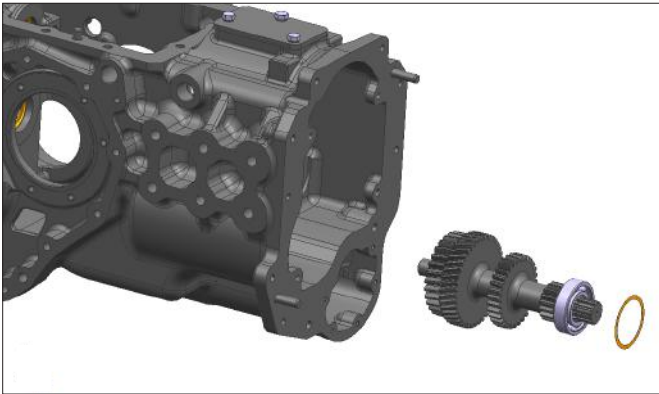

25. Remove the shim and range lay shaft assembly. Tie the shim with intermediate plate.

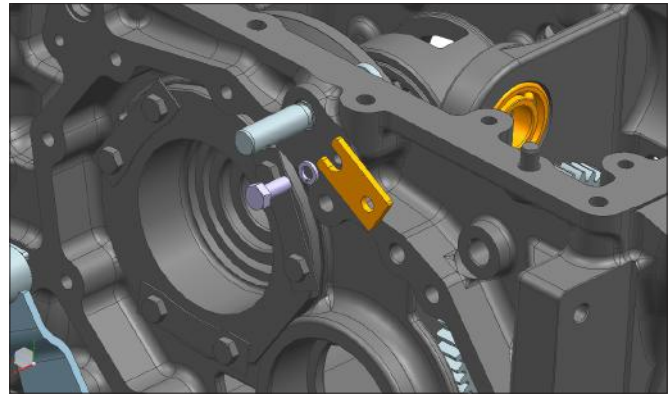

26. Remove the bolt of PTO pivot lug and remove the locking strip.

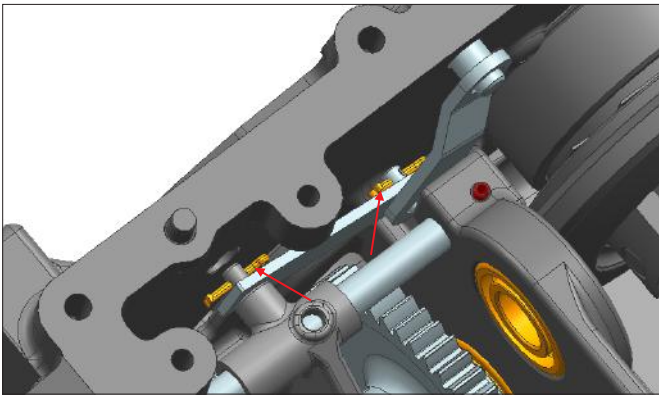

27. Remove the cotter pins of PTO link shifter.

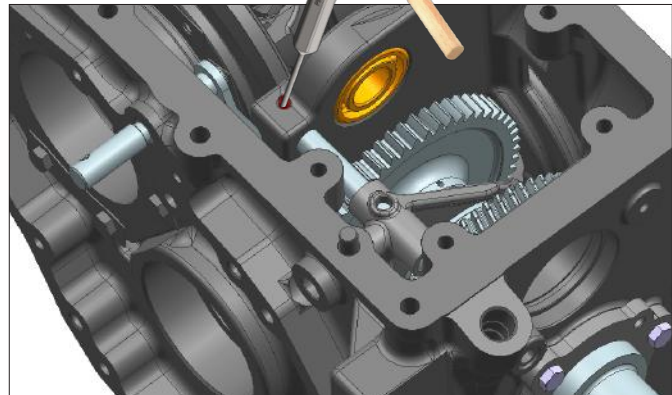

28. Remove the cotter sleeve of PTO shifter rod.

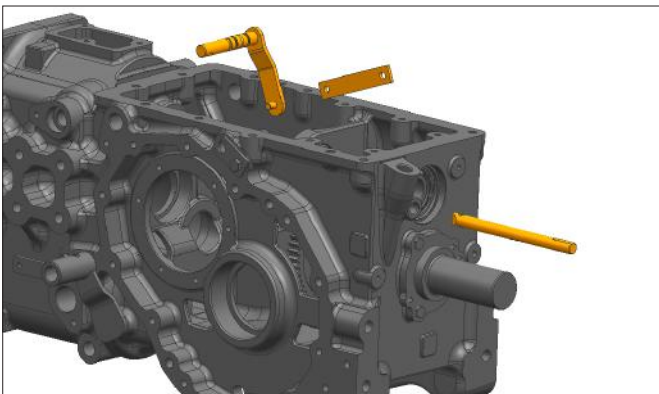

29. Remove the PTO shifter linkage and PTO shifter rod.

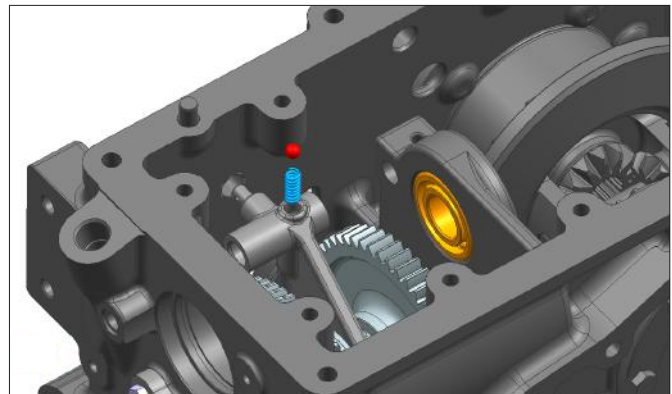

30. Remove the ball and spring of fork PTO and tie with fork.

A.3 Disassembly of Differential Housing

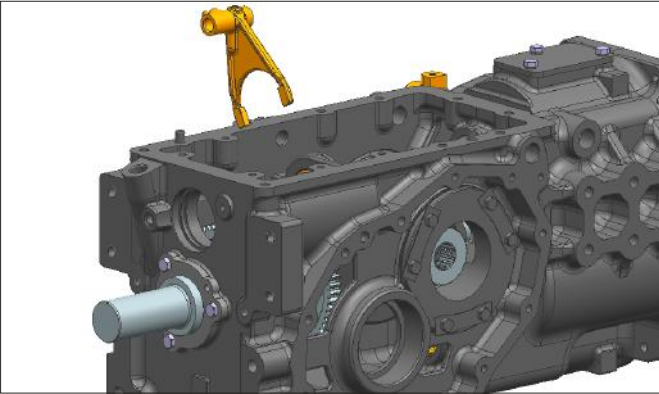

31.Remove the fork PTO.

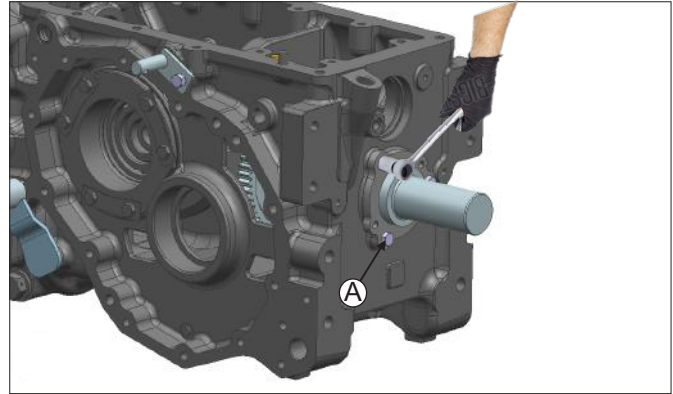

32.Remove the bolts of cover PTO output shaft.

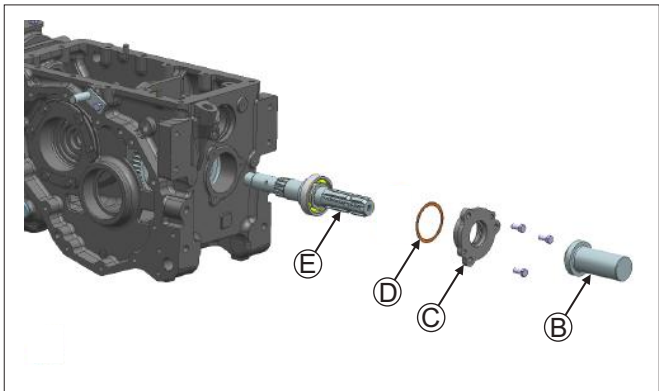

33.Remove the PTO cap (B), cover (C), shim (D) and PTO shaft rear (E).

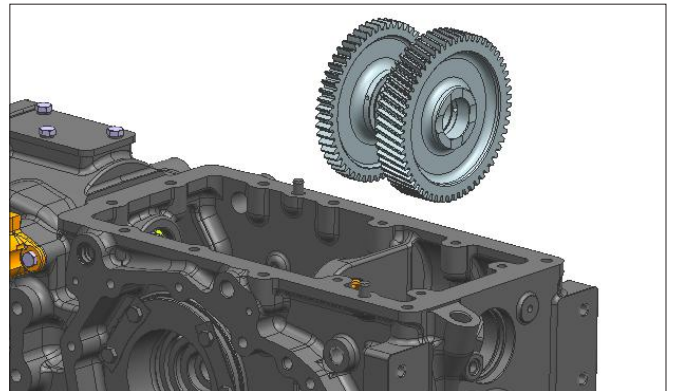

34.Remove the PTO gears, shifter sleeve and hub.

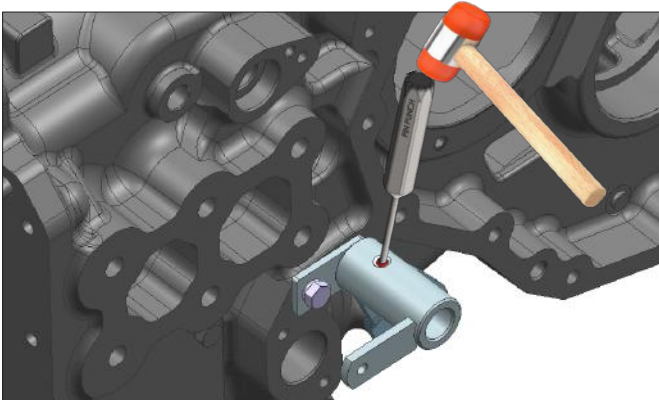

35.Remove the cotter sleeve of 4WD pivot rod.

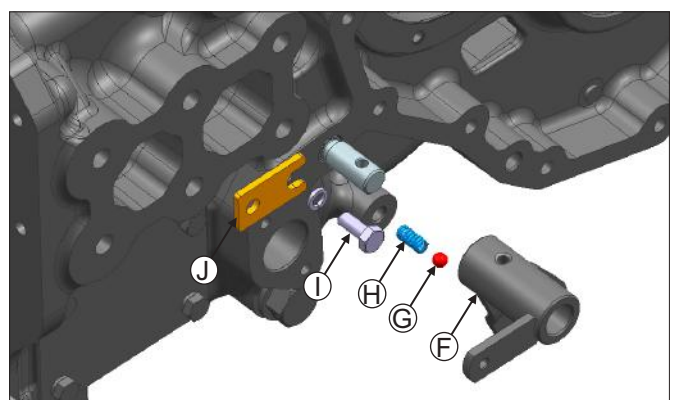

36.Remove the bolt (I) of 4WD pivot rod and remove the 4WD pivot lug (I), ball (G), spring (H) and locking strip (J). Tie ball and spring with pivot lug.

A.3 Disassembly of Differential Housing

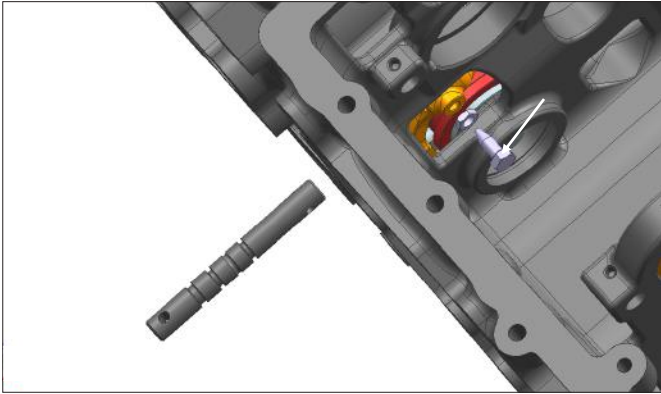

37.Remove the bolt of fork 4WD and remove 4WD pivot rod.

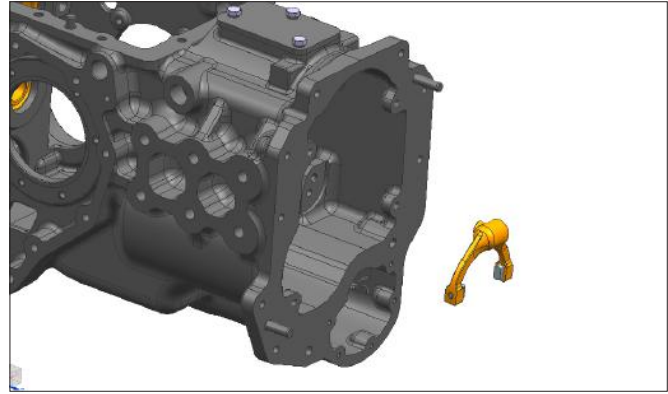

38.Remove the fork 4WD.

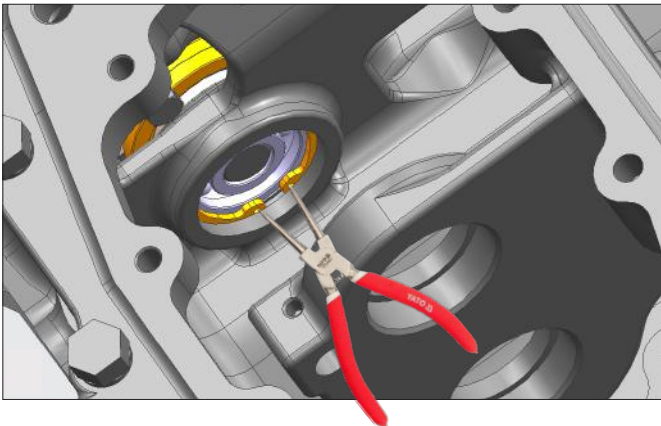

39.Remove the circlip of 4WD rear bearing.

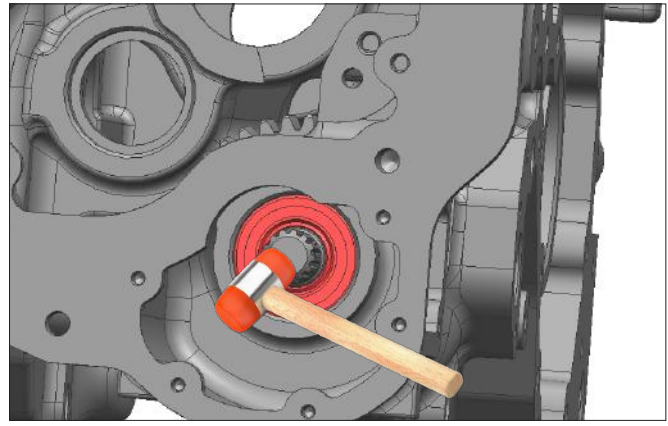

40.Slightly strike on front end of 4WD output shaft by using of hammer.

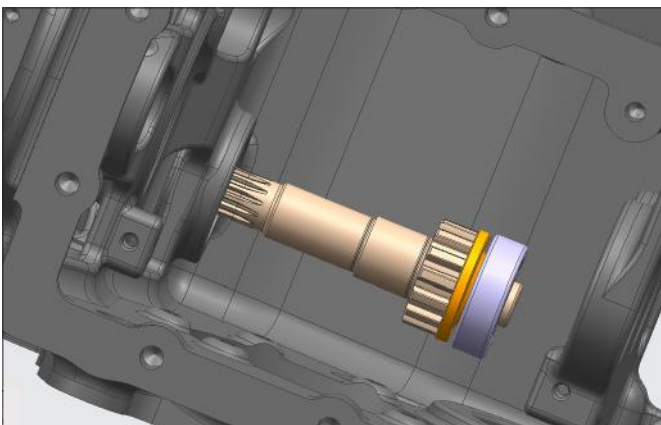

41.Remove the 4WD output shaft, ball bearing 6304 and spacer.

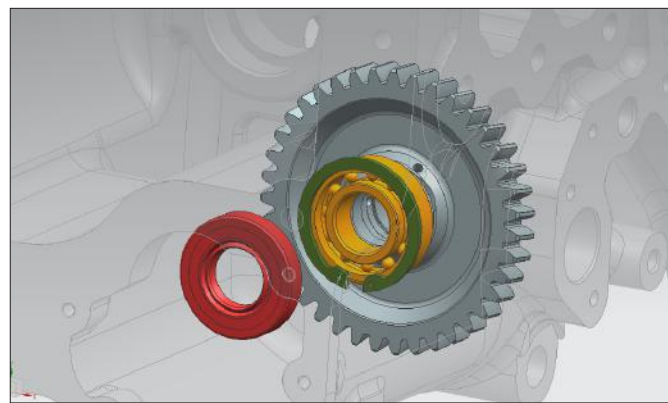

42.Remove the oil seal of 4WD output shaft. Replace the oil seal with new one during assembly.

A.3 Disassembly of Differential Housing

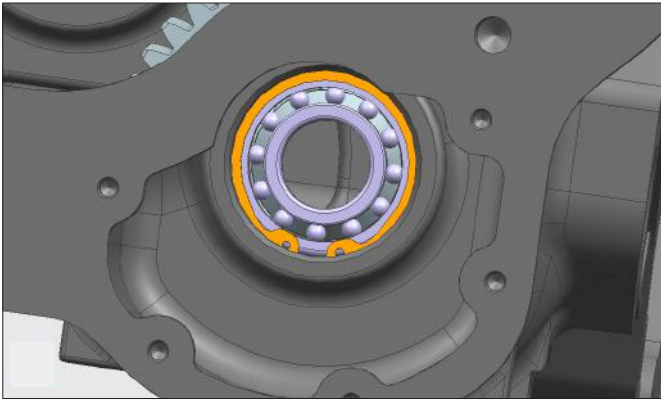

43. Remove the front circlip of 4WD output shaft.

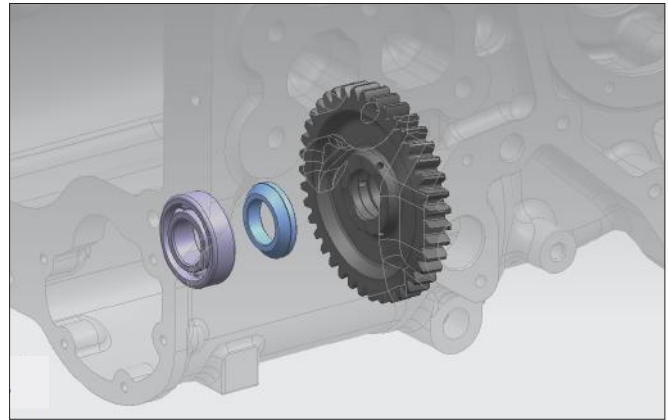

44. Remove the front ball bearing 6205 and spacer of 4WD output shaft.

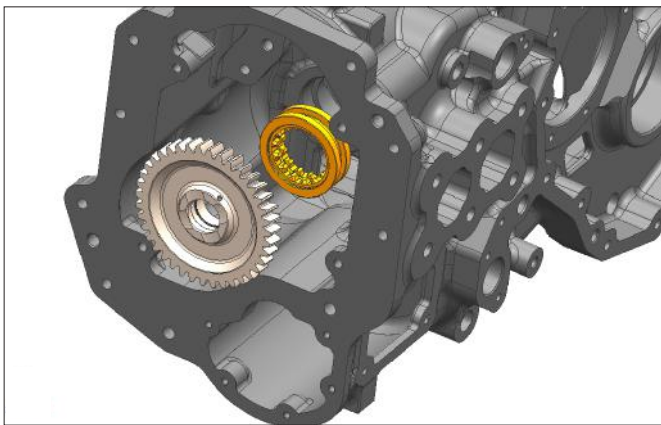

45. Remove the driven gear 4WD, shifter sleeve and spacer.

B.3 Disassembly of Trumpet Housing

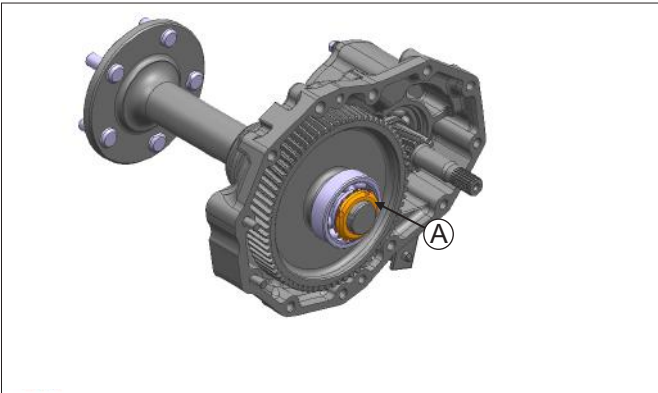

1.Unlock the locking washer (B) and remove the locking nut (A).

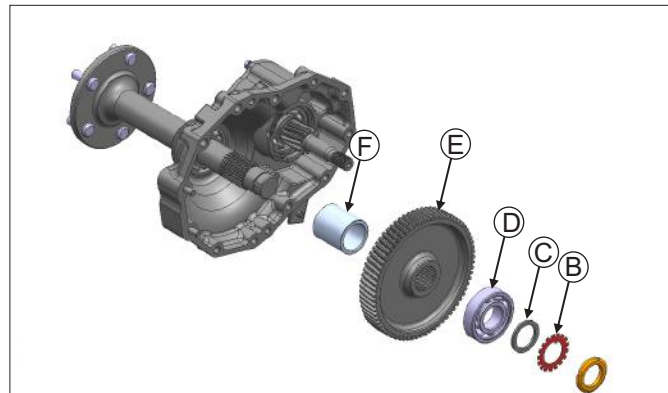

2.Remove the locking washer (B), spacer (C) bearing(D) ,bull gear (E) and sleeve(F).

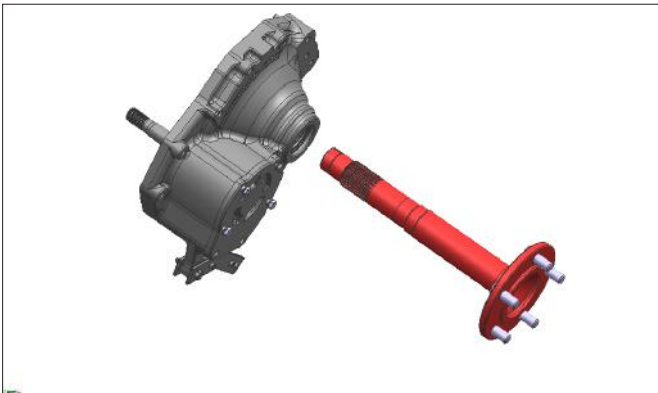

3.Remove the rear axle and oil seal. Discard the Oil Seal and replace with new one during assembly.

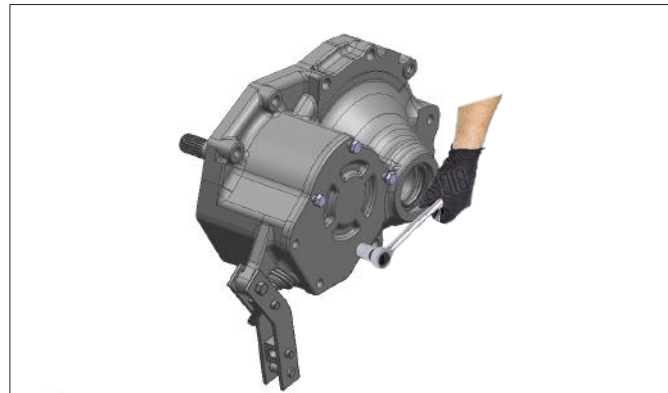

4.Remove the bolts of brake cover.

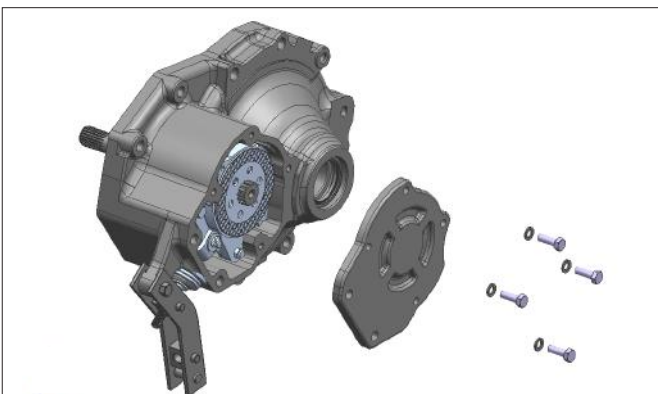

5.Remove the brake cover.

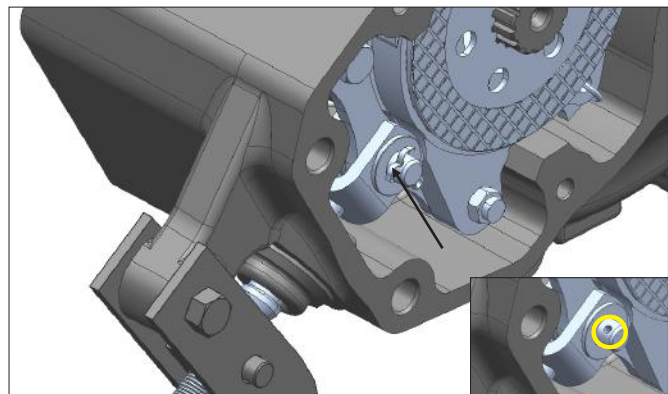

6.Remove the split pin.

B.3 Disassembly of Trumpet Housing

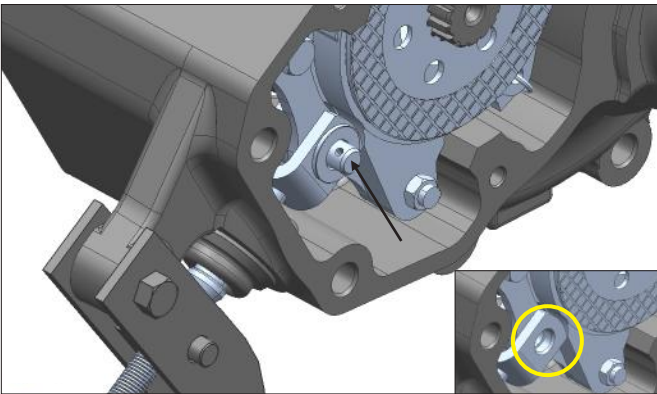

7.Remove the bolt of brake actuating rod.

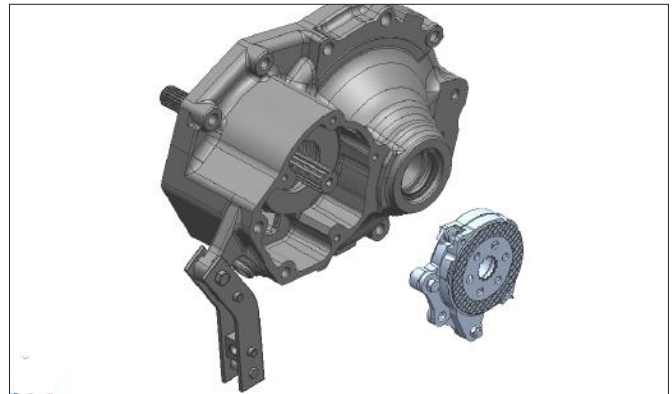

8.Remove the brake assembly.

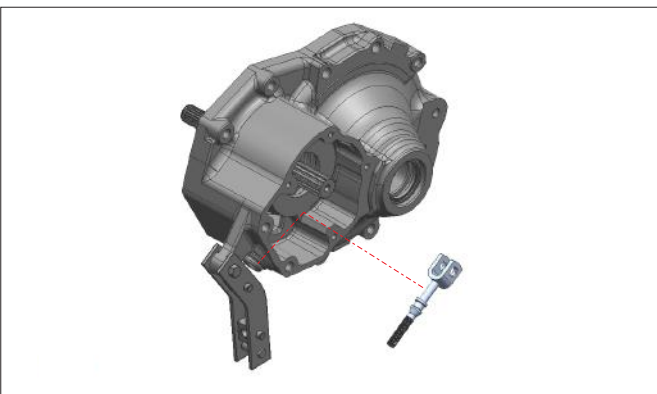

9.Remove the brake actuating rod.

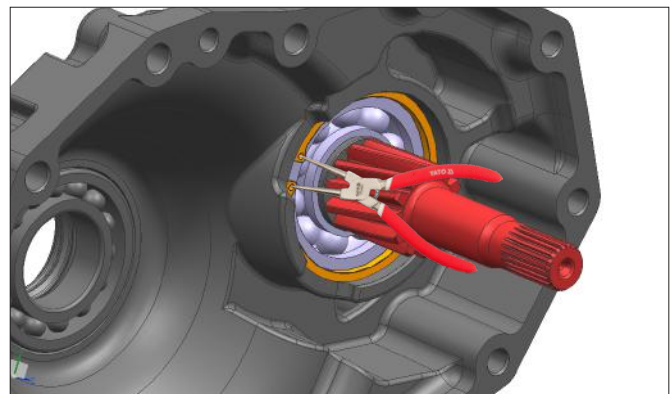

10.Remove the circlip of bull shaft bearing.

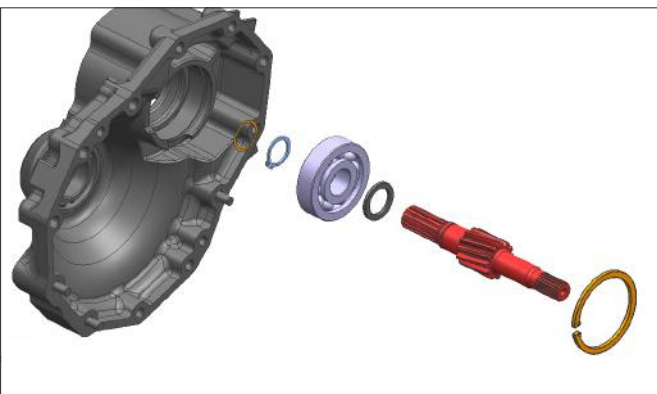

11.Remove the bull shaft, spacer and bearing.

C.3 Disassembly of Tail Pinion Shaft

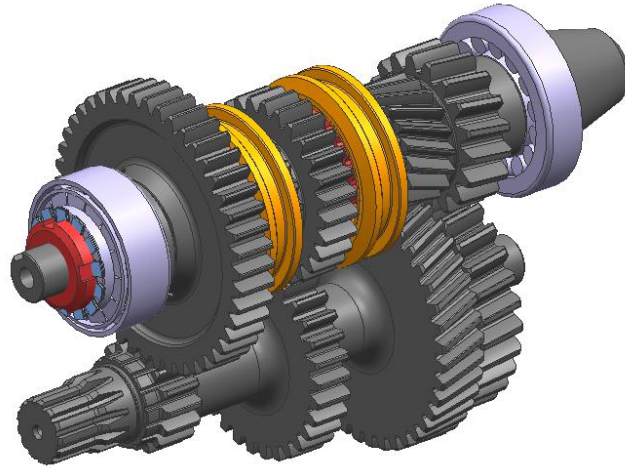

Exploded View

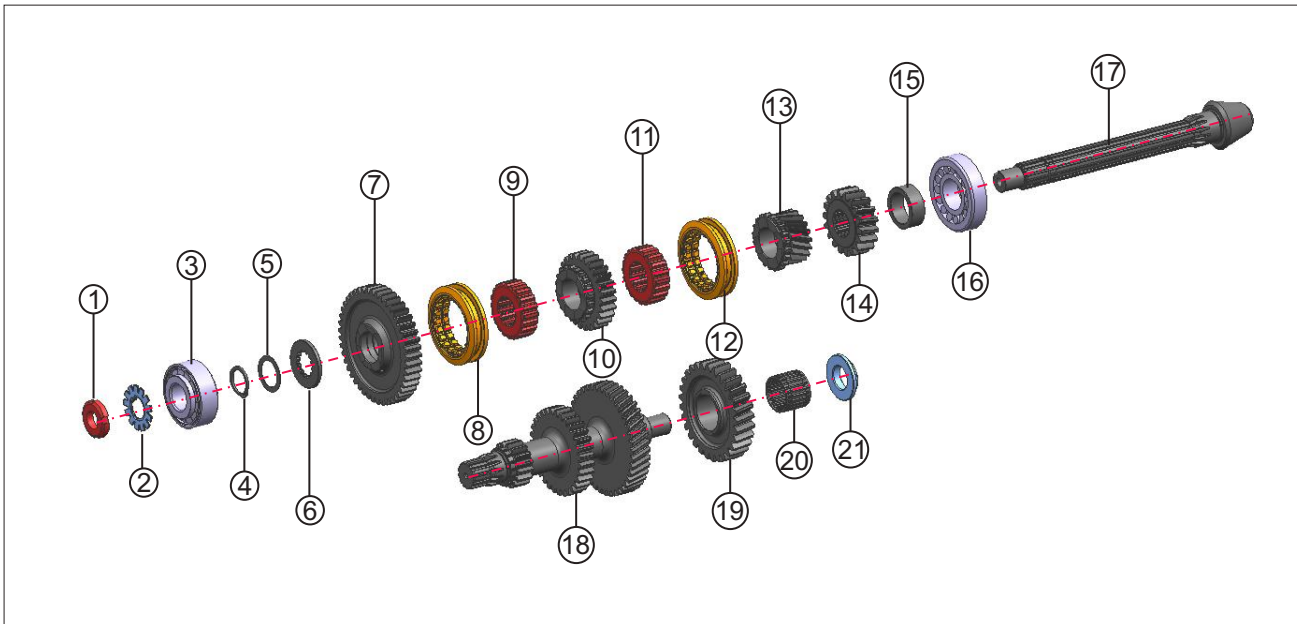

1	Nut
2	Locking Washer
3	Taper Bearing
4	Circlip
5	Shim
6	Splined Washer
7	Dog Gear Low

8	Shifter Sleeve
9	Hub
10	Dog Gear Medium
11	Hub
12	Shifter Sleeve
13	Dog Gear High
14	Driver Gear 4WD

15	Spacer
16	Taper Bearing
17	Tail Pinion
18	Range Lay Shaft
19	Idler Gear 4WD
20	Needle Roller Brg.
21	Spacer

C. 3 Disassembly of Tail Pinion Shaft

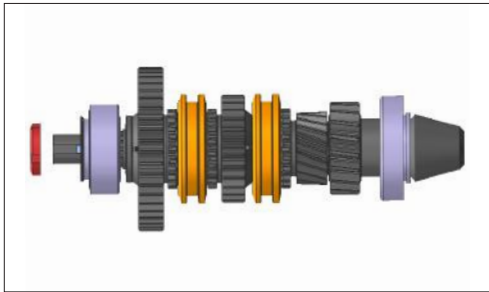

a. Remove the lock nut.

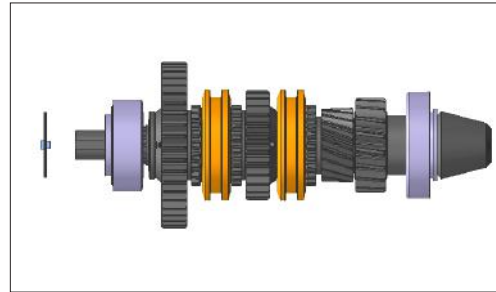

b. Remove the locking washer.

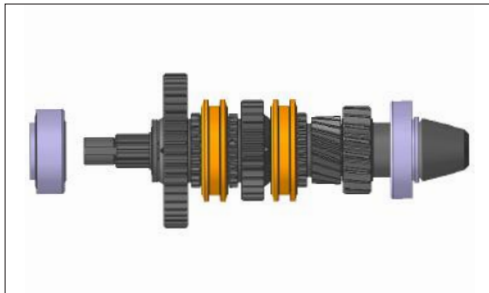

c. Remove the taper roller bearing.

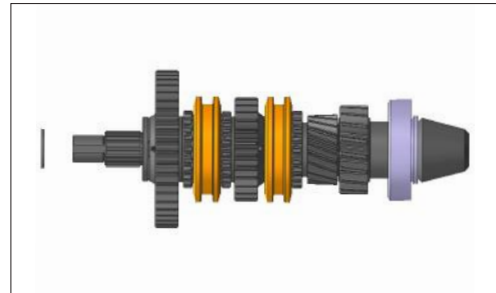

d. Remove the circlip.

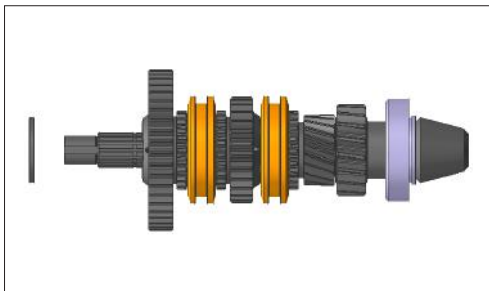

e. Remove the thrust washer.

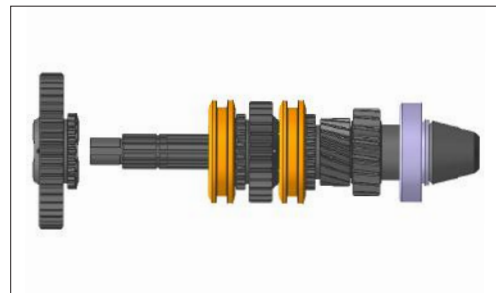

f. Remove the low dog gear.

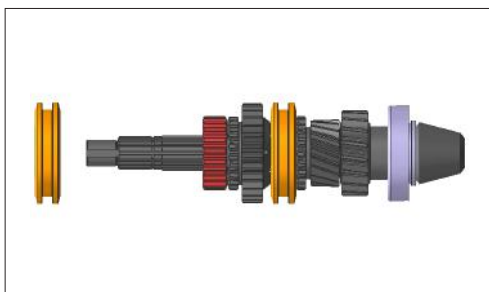

g. Remove the shifter sleeve.

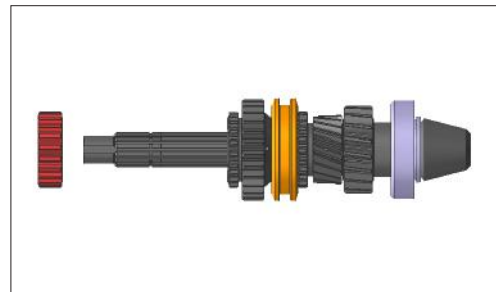

h. Remove the hub.

C.3 Disassembly of Tail Pinion Shaft

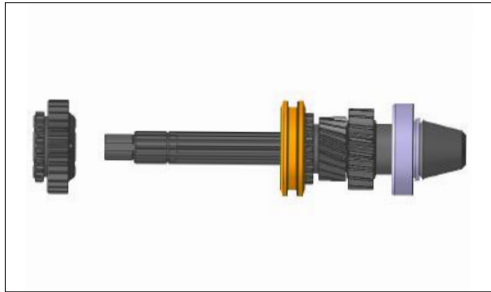

l. Remove the medium dog gear.

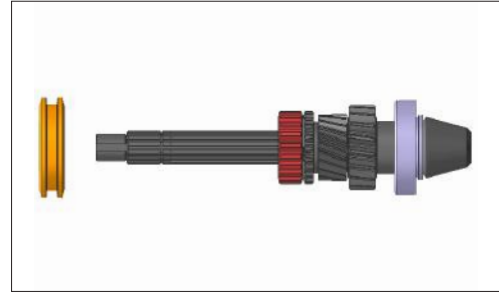

j. Remove the shifter sleeve.



k. Remove the hub.



l. Remove the High Dog Gear.



m. Remove the driver gear 4WD.



n. Remove the spacer.

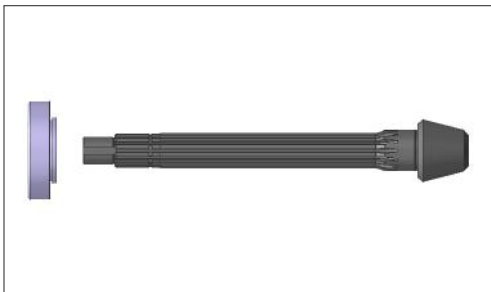

o. Remove the taper roller bearing.

D.3 Disassembly of Range Lay Shaft

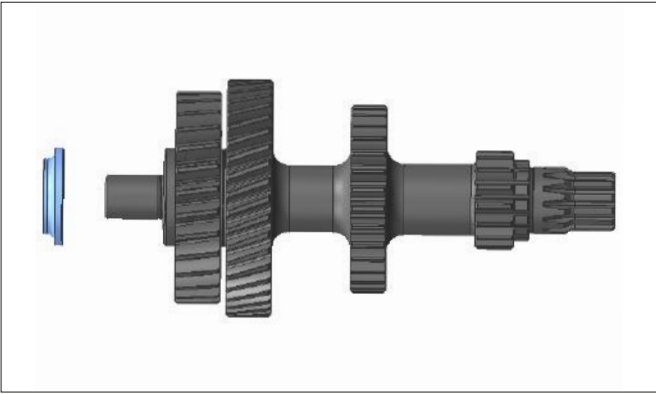

a. Remove the spacer.



b. Remove the idler gear 4WD.

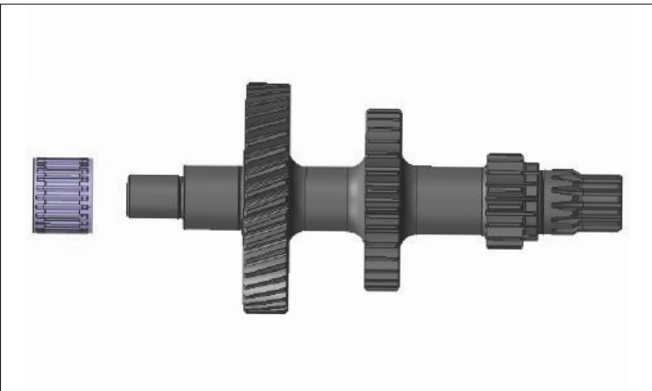

c. Remove the needle roller bearing.

E.3 Disassembly of Differential Sub Cage

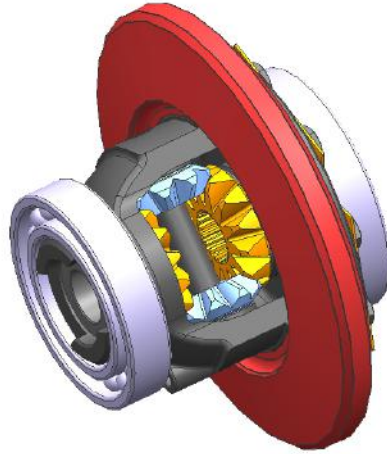

Exploded View

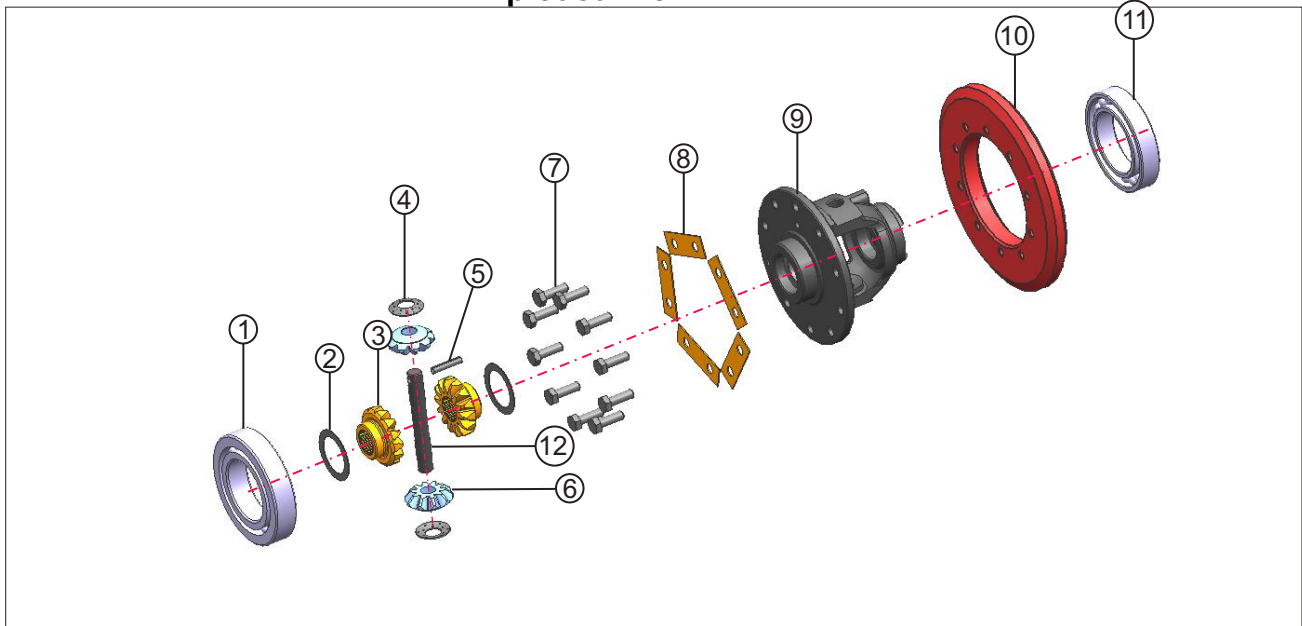

1	Ball Bearing 6011
2	Diff Side Gear Liner
3	Diff. Side Gear 14T
4	Thrust Washer
5	Spring Cotter Sleeve
6	Diff Pinion Gear 10T

7	Bolt
8	Locking Washer
9	Diff Cage Assembly
10	Crown Wheel
11	Ball Bearing 6211
12	Pinion Shaft

E.3 Disassembly of Differential Sub Cage



a.Remove the differential cage ball bearing 6011.



b.Remove the differential cage ball bearing 6211.

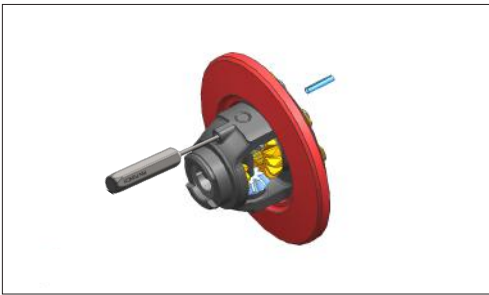

c.Remove the spring cotter sleeve.



d.Remove the pinion shaft.

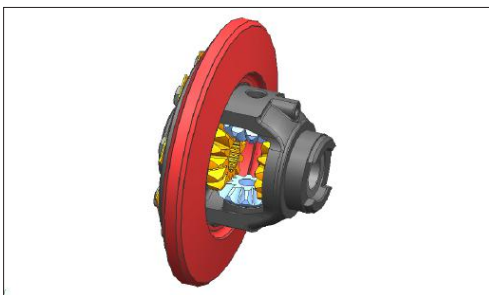

e. Remove the differential pinion gear.

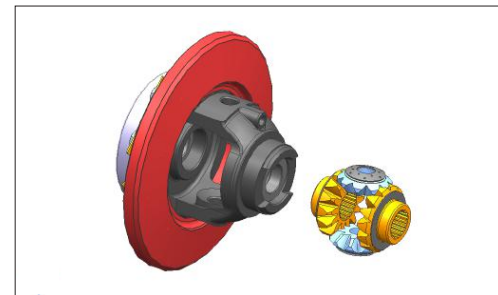

f.Remove the all differential side gear, thrust washer and liner.



g. Remove the bolt and locking washer.



h.Remove the crown wheel.

Assembly of Gear Box

CONTENTS

REF. NO	DESCRIPTION	PAGE
A.4	Torque Chart-Gear Box	52-53
B.4	Inspection of Synchronizer Assembly	54-55
C.4	Assembly of Synchronizer	56
D.4	Slip Clutch Assembly	57
E.4	Assembly of Gear Box	58-72
F.4	Lay Shaft Assembly	60-61
G.4	Intermediate Shaft Assembly	64

A.4 Torque Chart-Gear Box

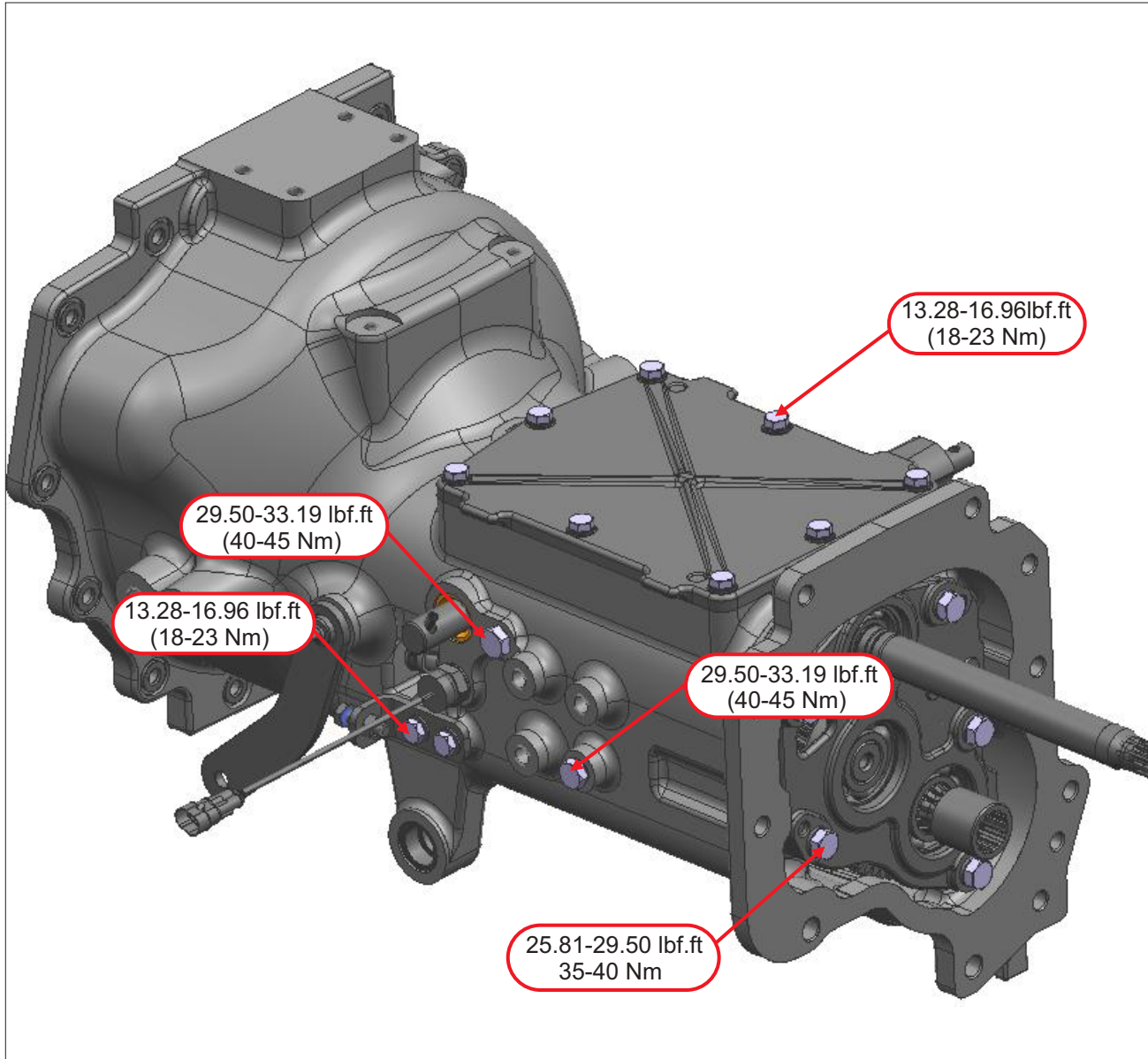

A.4 Torque Chart-Gear Box

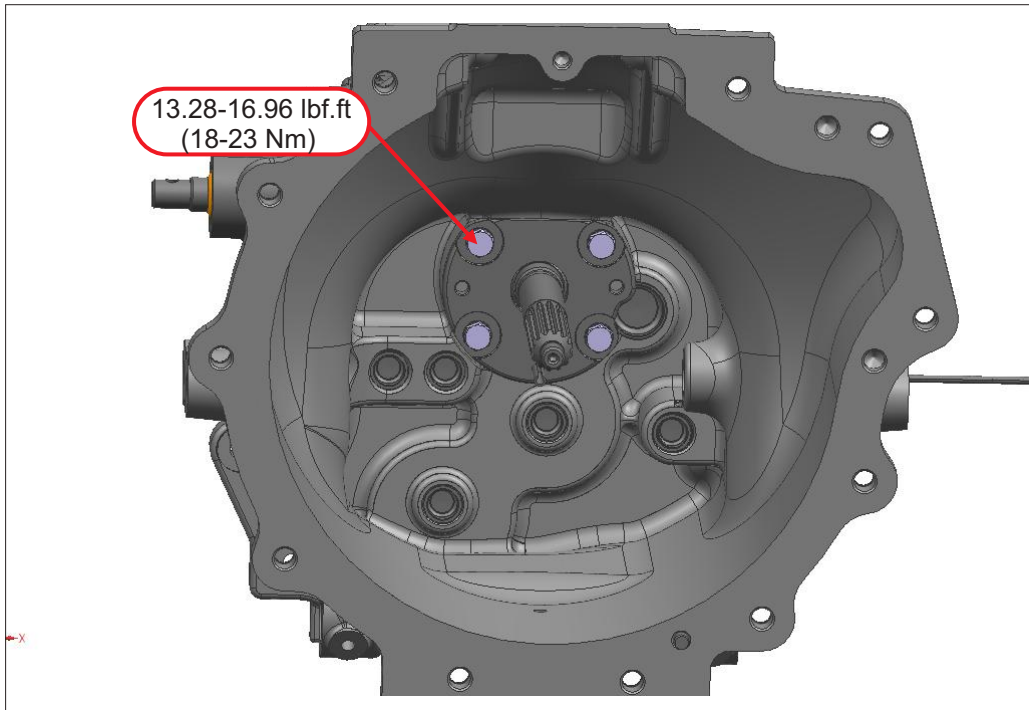
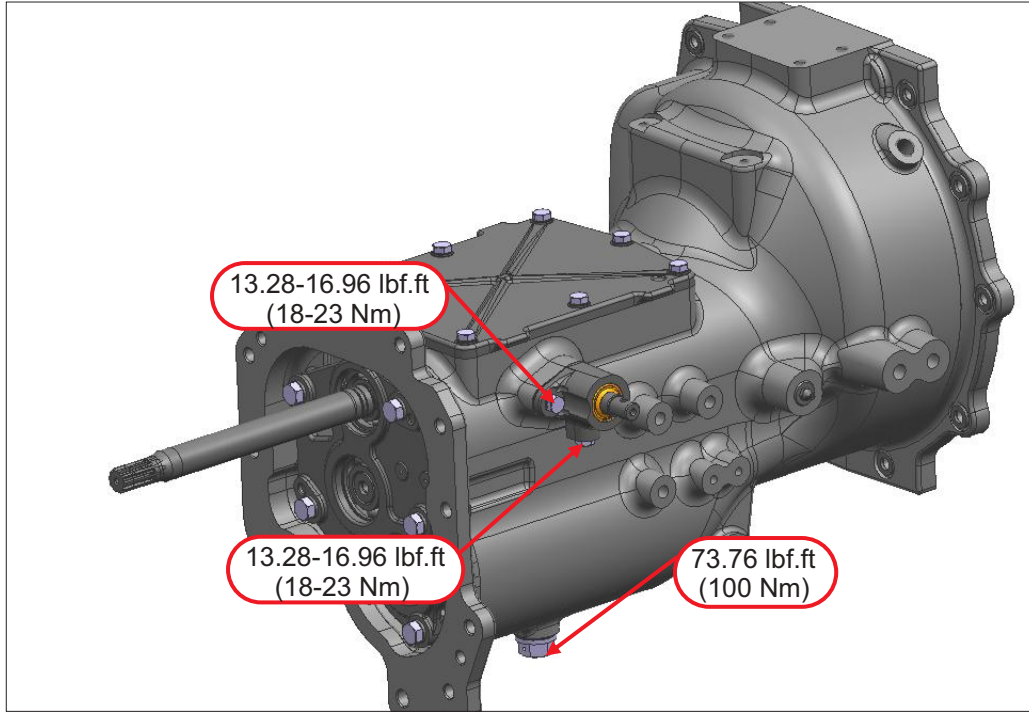

B.4 Inspection of Synchronizer Assembly

1. Inspect the synchro rings for scoring, cracks, and damage (A)

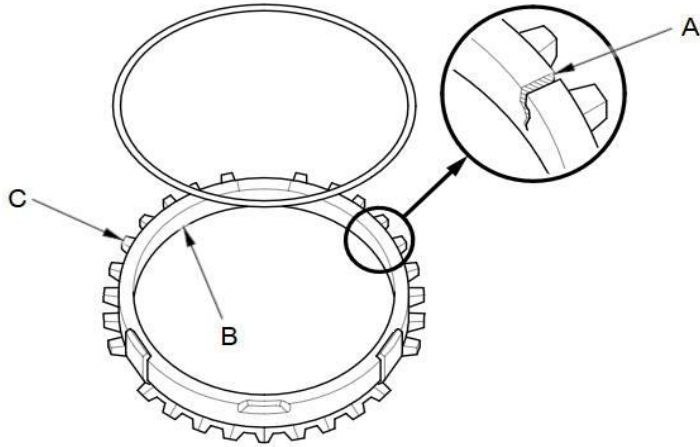

Example of synchro ring teeth

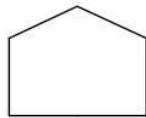

GOOD

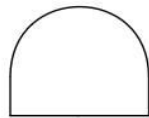

WORN

2. Inspect the inside of each synchro ring (B) for wear. Inspect the teeth (C) on each synchro ring for wear (rounded off).

3. Inspect the teeth (A) on each synchro sleeve and the matching teeth on each gear for wear (rounded off).

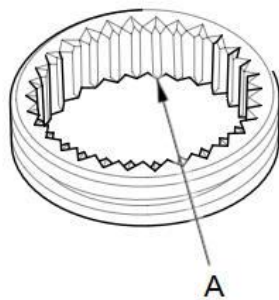

Example of synchro sleeve teeth and gear teeth

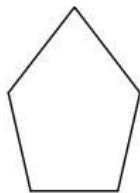

GOOD

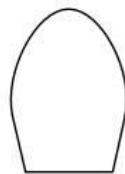

WORN

B.4 Inspection of Synchronizer Assembly

4. Inspect the synchro teeth on gear for scoring, cracks, and damage (A).

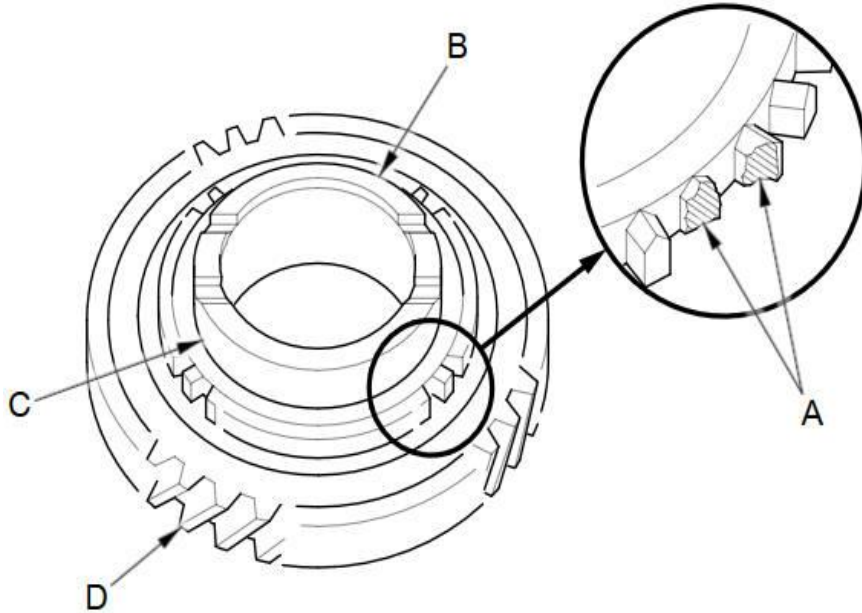

5. Inspect the thrust surface (B) on each gear hub for wear.

6. Inspect the cone surface (C) on each gear hub for wear and roughness.

7. Inspect the teeth on all gears (D) for uneven wear, scoring, and cracks.

8. Coat the cone surface of each gear with MTF, and place its synchro ring on it. Rotate the synchro ring, making sure that it does not slip.

9. Measure the clearance between each gear (A) and its synchro ring (B) all around the gear. Hold the synchro ring against the gear evenly while measuring the clearance. If the clearance is less than the service limit, replace the synchro ring and gear.

C.4 Assembly of Synchronizer



a. Take the synchro hub.

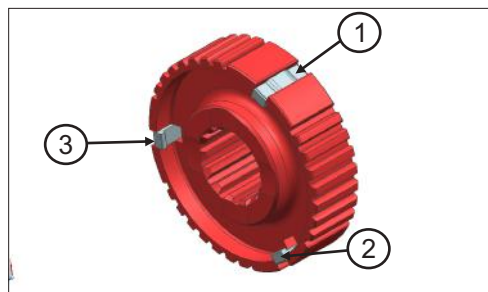

b. Assemble the three strut in synchro hub.



c. Take two spring lock ring.



d. Assemble spring lock ring in synchro hub and lock the all strut on both side .

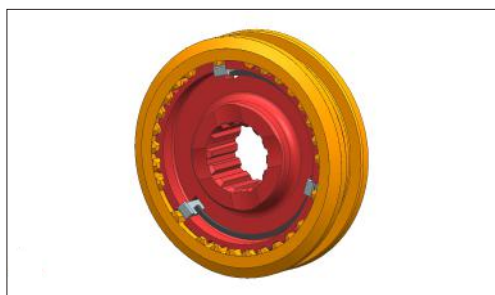

e. Assemble the shifter sleeve.

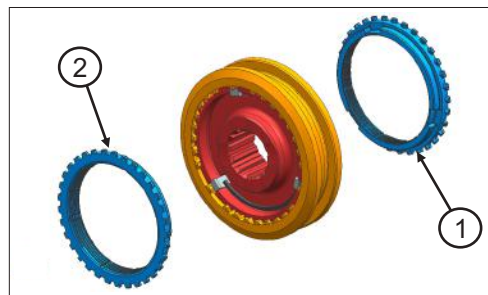

f. Take the two synchro cone.



g. Assemble the synchro cone on both side.

D.4 Slip Clutch Assembly

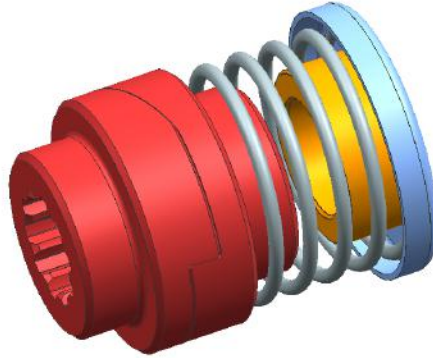

Exploded View

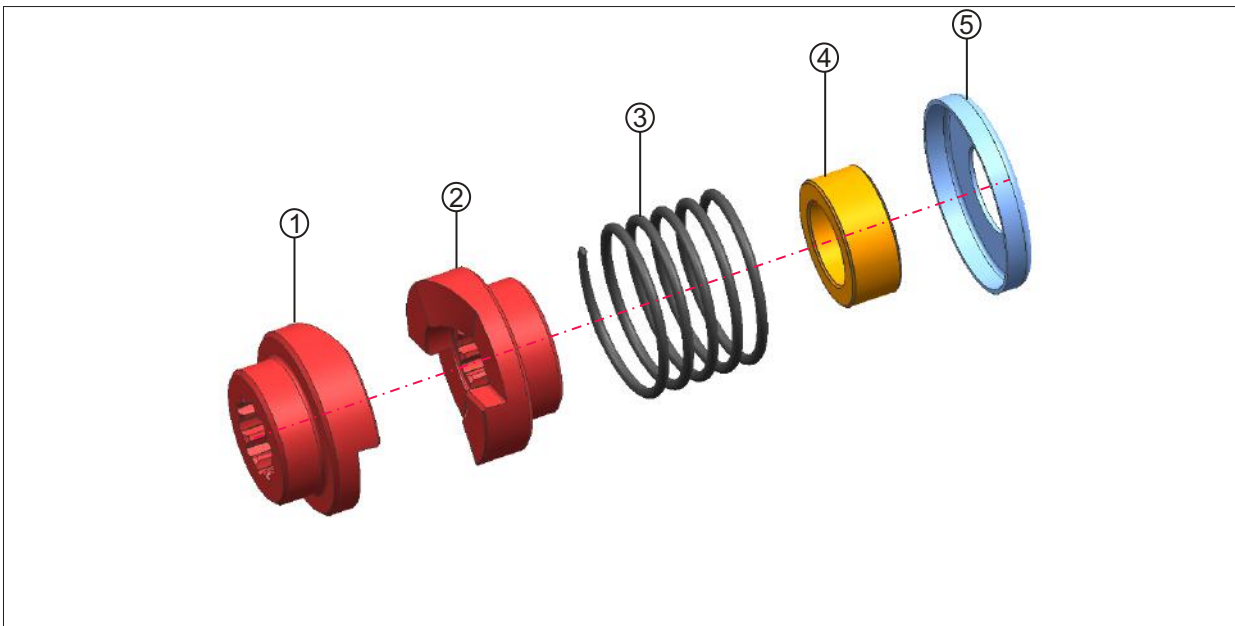

1	Slip Clutch Coupler - 1
2	Slip Clutch Coupler - 2
3	Spring
4	Spacer
5	Spring Reatainer

E.4 Assembly of Gear Box

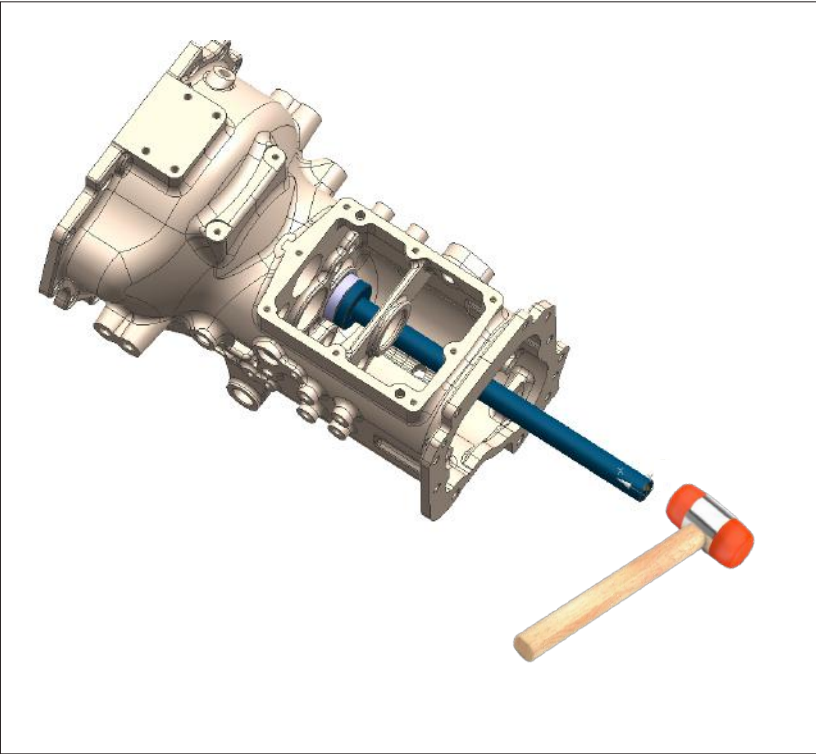

A. Press the ball bearing 1063 of lay shaft assembly in clutch housing by using mandrel (9+9 007).

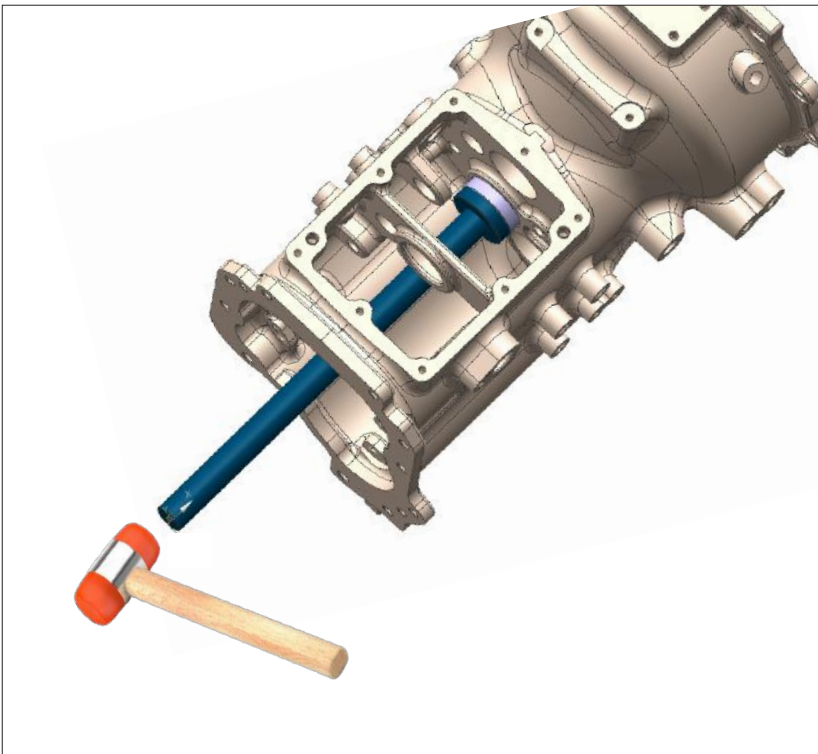

B. Press the ball bearing 1063 of intermediate shaft assembly in clutch housing by using mandrel (9+9 007).

E.4 Assembly of Gear Box

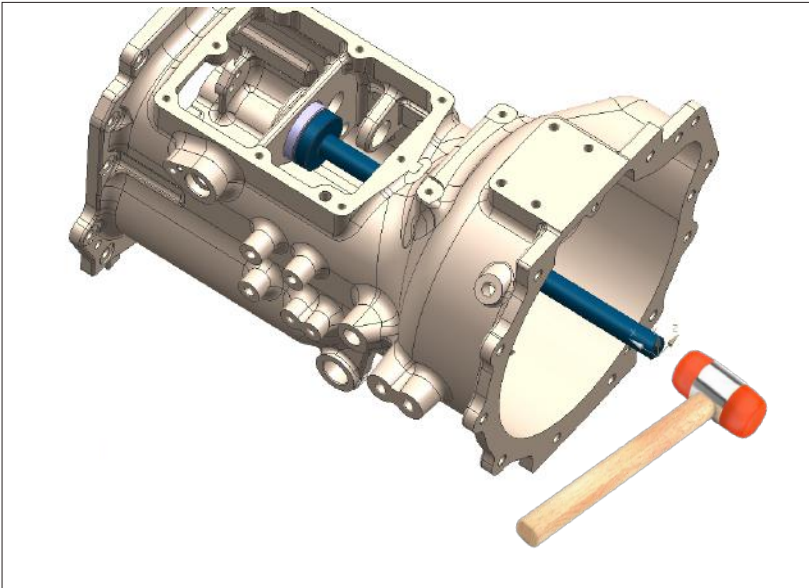

C. Press the ball bearing 6007 of input shaft assembly in clutch housing by using mandrel (9+9 011).

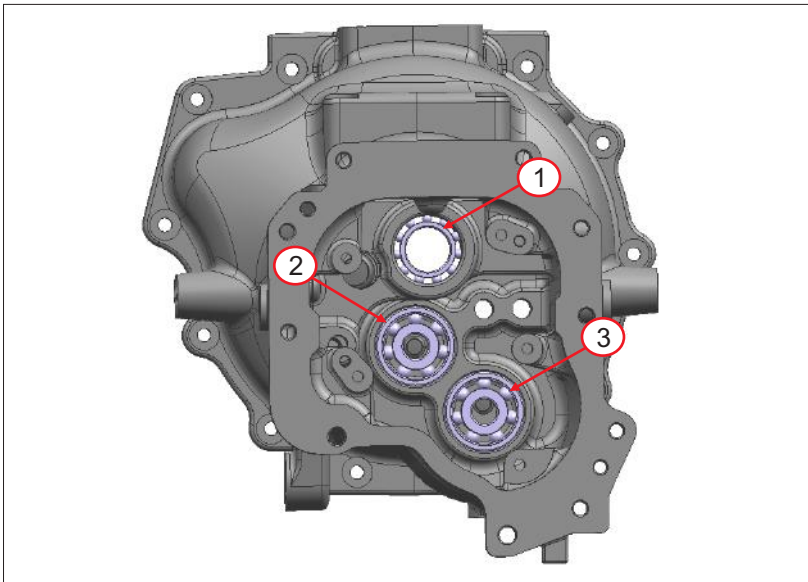

- i. Ball bearing 6007 for input shaft assembly
- ii. Ball bearing 1063 for intermediate shaft assembly
- iii. Ball bearing 1063 for lay shaft assembly

F.4 Lay Shaft Assembly



a. Assemble the lay shaft in ball bearing 6206.



b. Insert the 2ND gear.



c. Insert the hub.

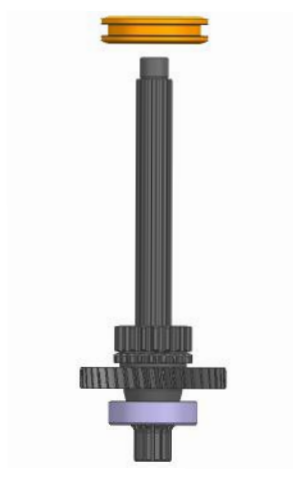

d. Insert the shifter sleeve.



e. Insert the 3RD dog gear.



f. Insert the thrust washer.

F.4 Lay Shaft Assembly



g. Insert the 1ST gear.



h. Insert the hub.



i. Insert the shifter sleeve.



j. Insert the spacer.



k. Insert the spacer in dog clutch gear.

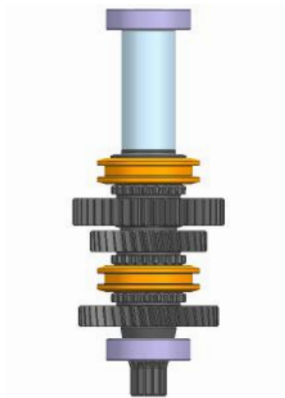

l. Assemble the bearing 1063.

G.4 Intermediate Shaft Assembly



a. Assemble intermediate shaft in ball bearing 6305.



b. Insert the spacer.



c. Insert the reverse shuttle gear.



d. Insert the sleeve and synchro assembly.



e. Insert the forward shuttle gear.



f. Insert the spacer of FWD gear.

E.4 Assembly of Gear Box



1. Assemble the lay shaft assembly in clutch housing.

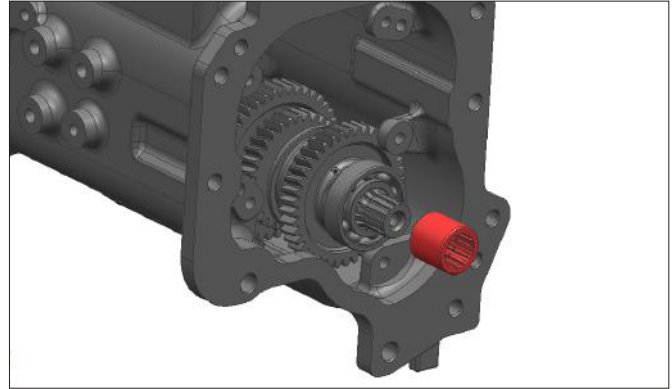

2. Assemble the coupling sleeve in lay shaft.

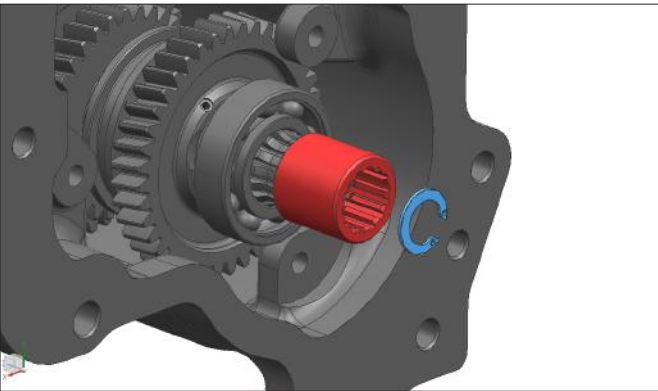

3. Lock the internal circlip.

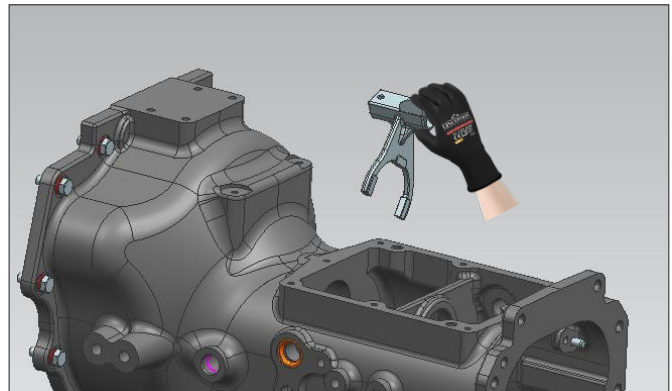

4. Insert the shifter fork 1st gear.

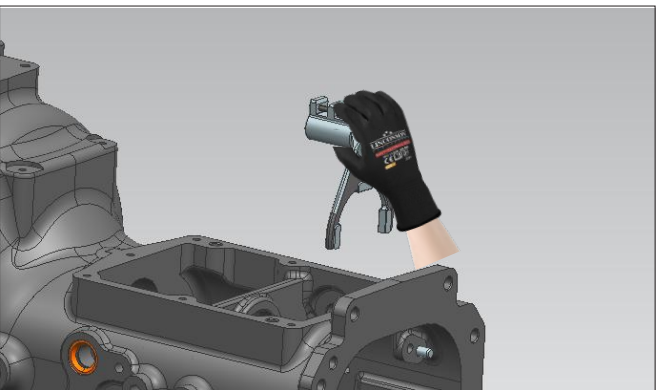

5. Insert the shifter fork 2nd-3rd gear.

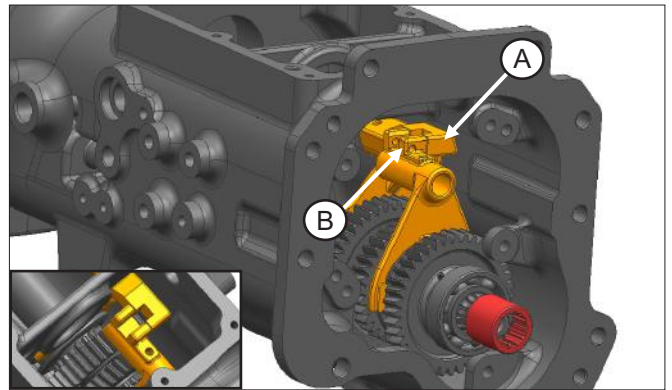

6. Assemble 1st (A) and 2nd-3rd (B) fork as per shown in picture.

E.4 Assembly of Gear Box

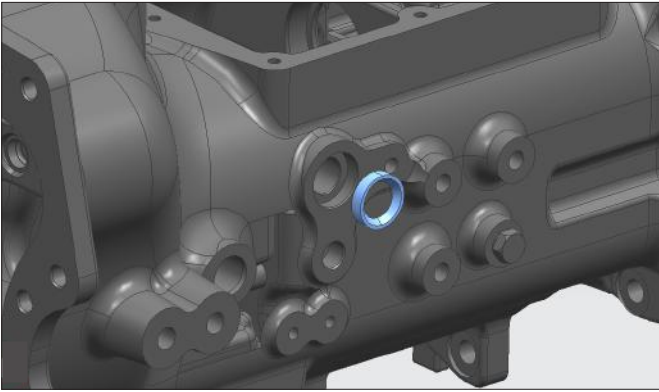

7. Assemble the oil seal of forward and reverse pivot lug in clutch housing.

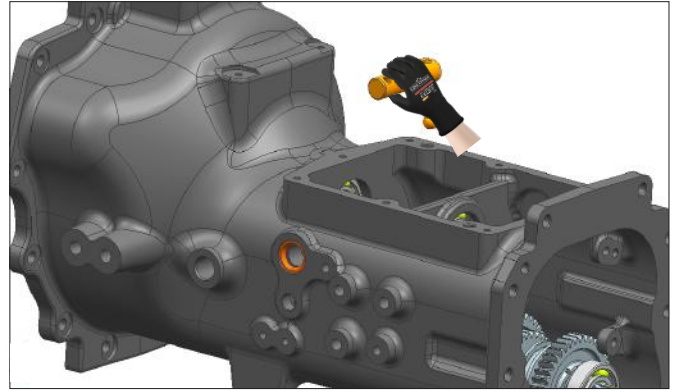

8. Assemble pivot lug of forward and reverse gears in clutch housing.

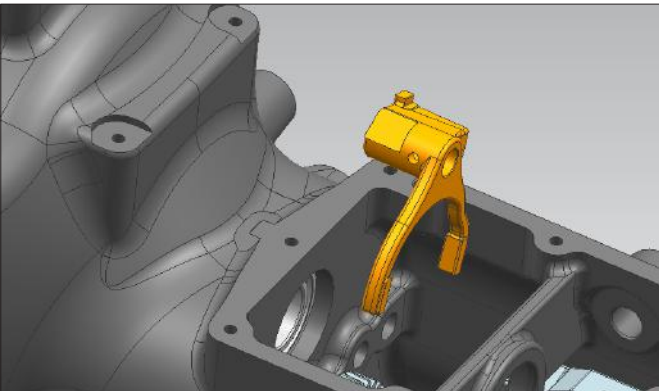

9. Insert the fork of forward and reverse gear.

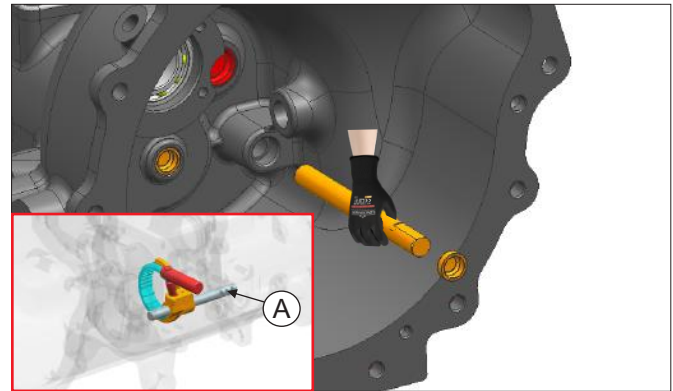

10. Insert the shifter rod from front side. Locking groove (A) should be outside of the face of clutch housing.

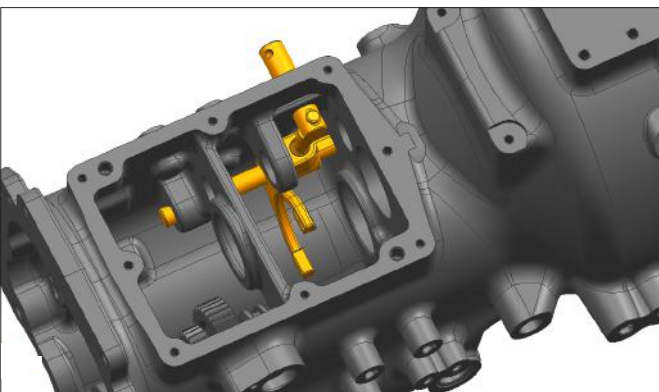

11. Assemble the shuttle fork , pivot lug and shifter rod as per show in figure.

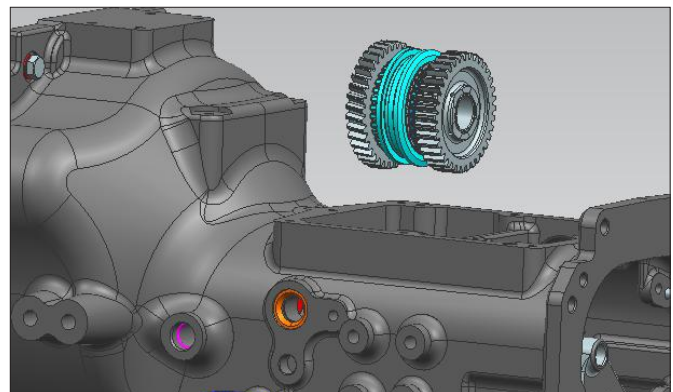

12. Assemble the shuttle gears and synchro assembly in intermediate shaft.

E.4 Assembly of Gear Box

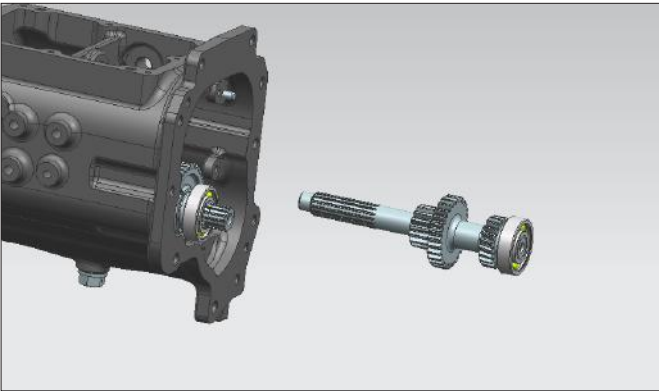

13. Assemble the intermediate shaft assembly.

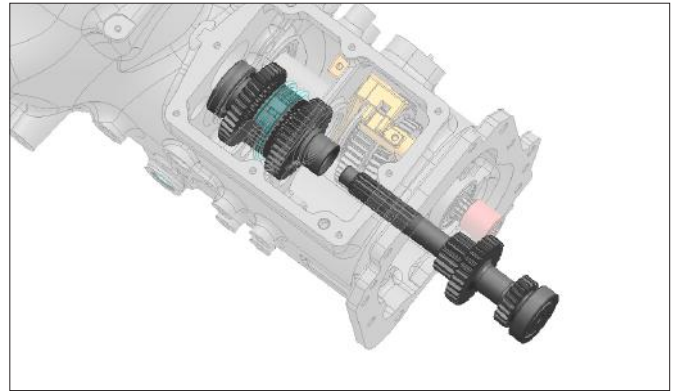

14. First hold synchronizer assembly and assemble intermediate shaft with press fitted bearing 6305.

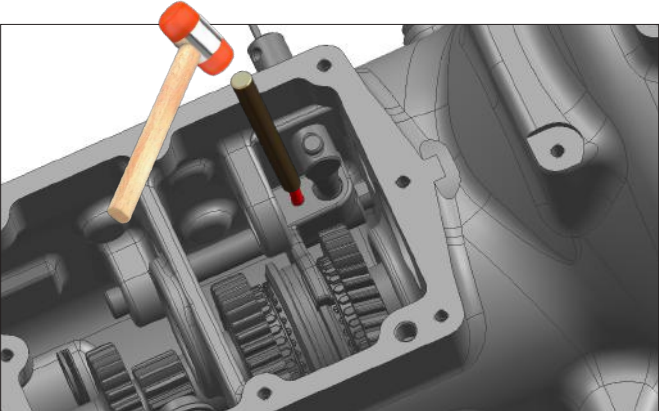

15. Insert the split pin in shuttle fork and engage the shifter rod.

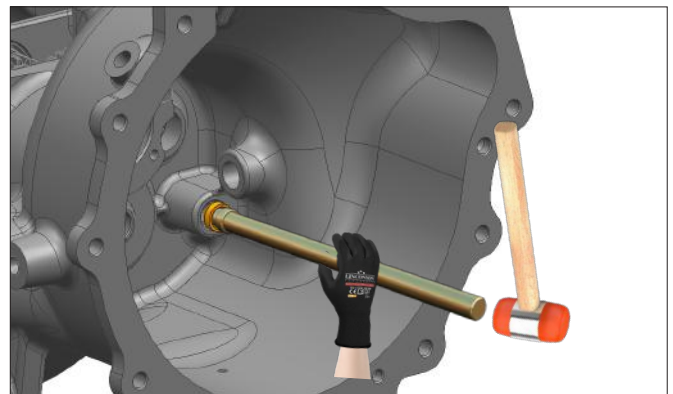

16. Pressing the cap in clutch housing to help of mandrel (9+9 010).

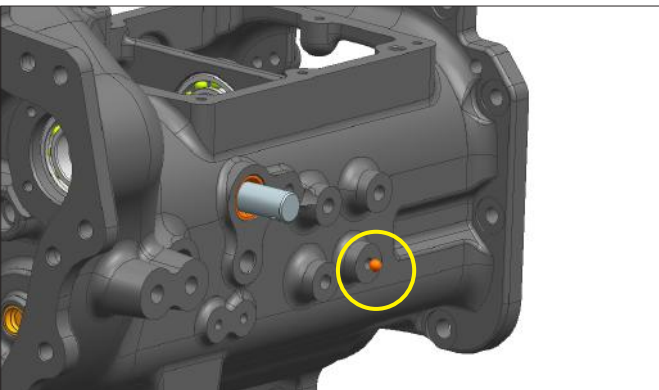

17. Insert the ball 5/16 in clutch housing.

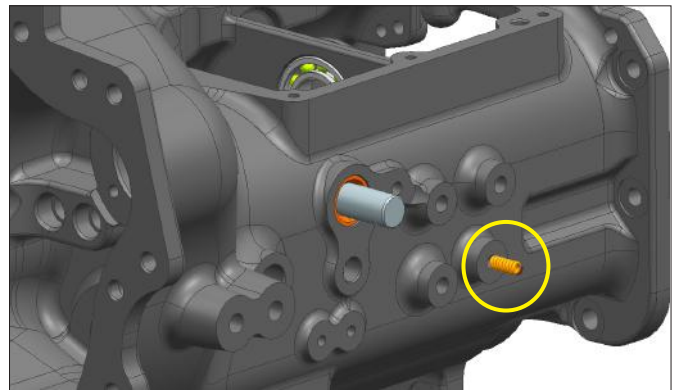

18. Insert the spring in clutch housing.

E.4 Assembly of Gear Box

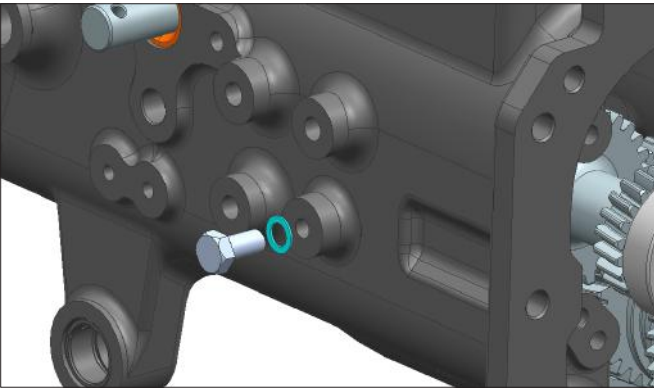

19. Apply loctite 243 on bolt. Tight the bolt of shuttle shifter rod.
Torque= 29.50-33.19 lbf.ft (40-45 Nm)

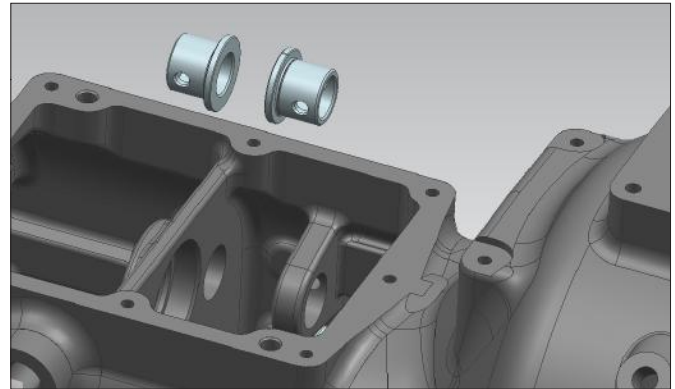

20. Insert the spacers.

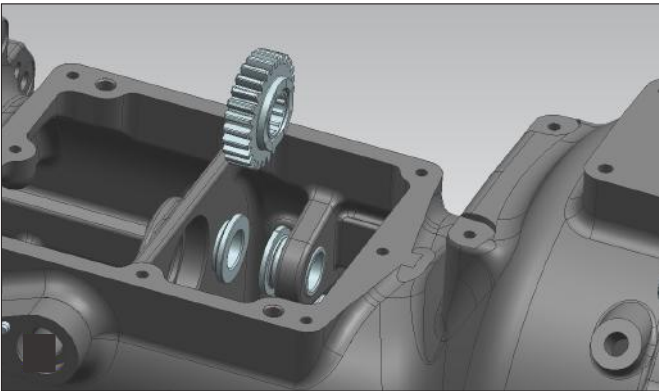

21. Assemble the idle gear between the spacers.
Note: Idle gear slot face should keep in front side of the clutch housing.

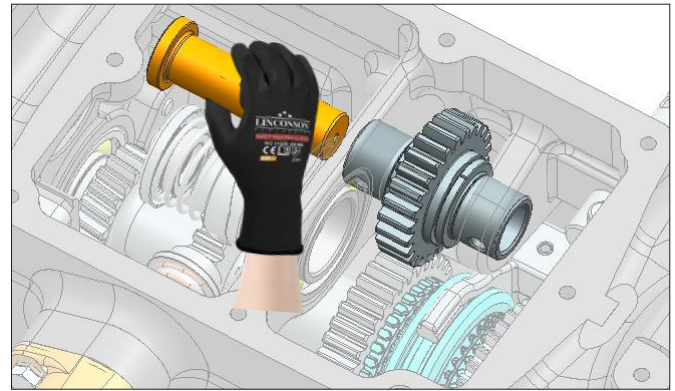

22. Insert the idle gear shaft reverse.

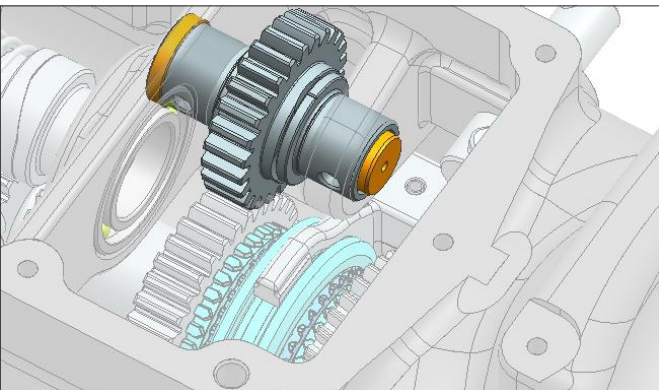

23. Align the hole of bush and gear shaft reverse.

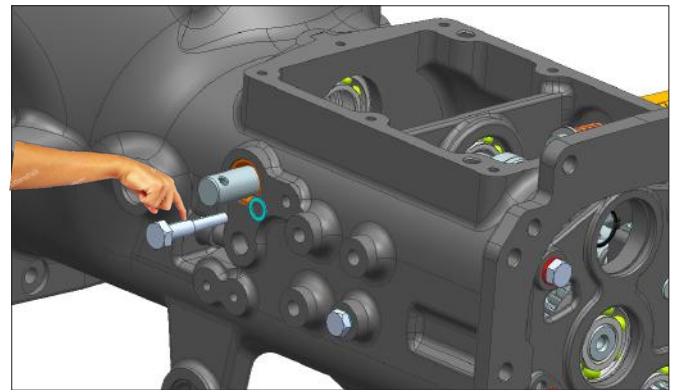

24. Apply loctite on the bolt and assemble the bolt in clutch housing.
(Loctite 243)

E.4 Assembly of Gear Box

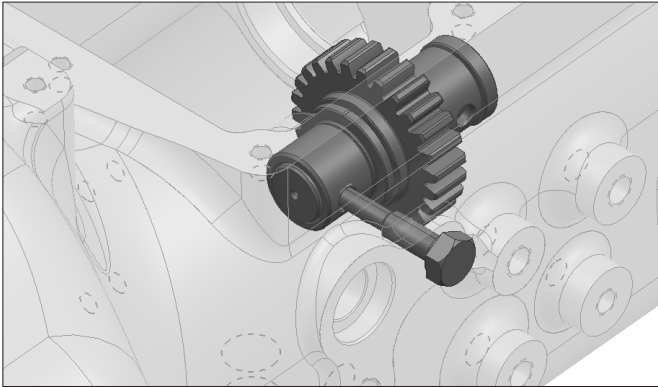

25. End of the bolt is match with hole of the idler gear shaft as shown in figure. Tight the bolt of the gear shaft reverse.

Torque= 29.50-33.19 lbf.ft (40-45 Nm)



26. Insert the required thickness of shim in bearing holder plate to maintain the lay shaft assembly float.

Float limit :- 0.05- 0.2 mm

Shim size available :- 0.1,0.2,0.5 mm

27. Exploded view of Bearing Holder Plate :

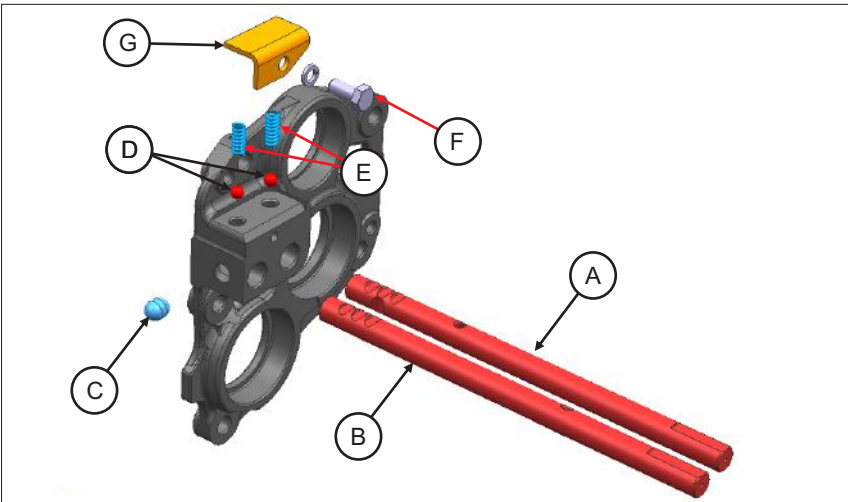

- A. Shifter Rod 2ND-3RD**
- B. Shifter Rod 1ST**
- C. Locking Pin**
- D. Ball 8 mm DIA**
- E. Spring**
- F. Bolt**
- G. Cover Plate for Spring**

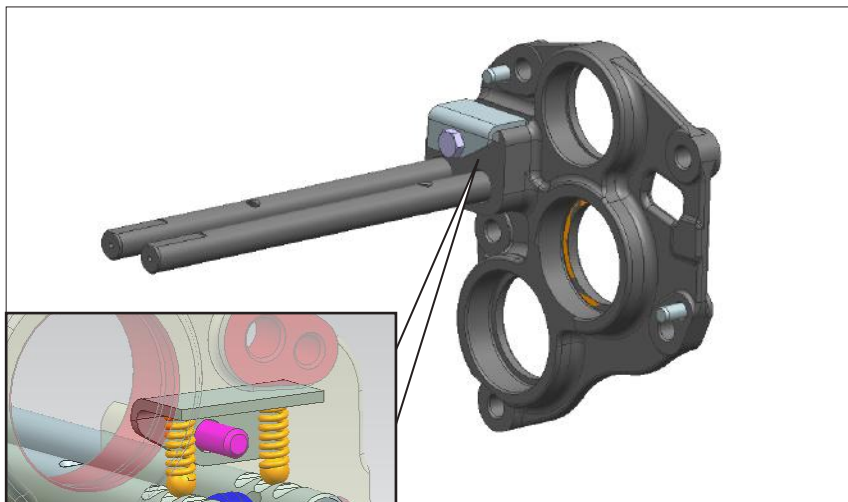

Assembly View

SOP :-

1. First insert shifter rod 2ND-3RD (A) in bearing holder plate.
2. After insert locking pin (C) in bearing holder plate.
3. Then next insert shifter rod 1ST (B).
4. Insert the ball 8 dia (D) in bearing holder plate.
5. Insert the spring (E) in bearing holder plate.
6. Assemble cover plate in bearing holder plate.
7. Tight the bolt. Torque=18-23 Nm.

E.4 Assembly of Gear Box

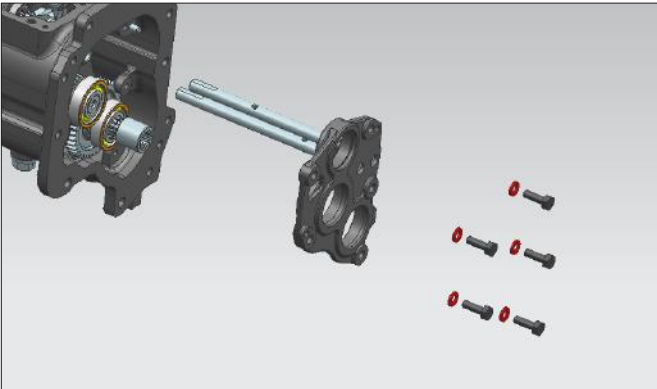

28. Apply loctite 243 on the bolt of bearing holder plate.

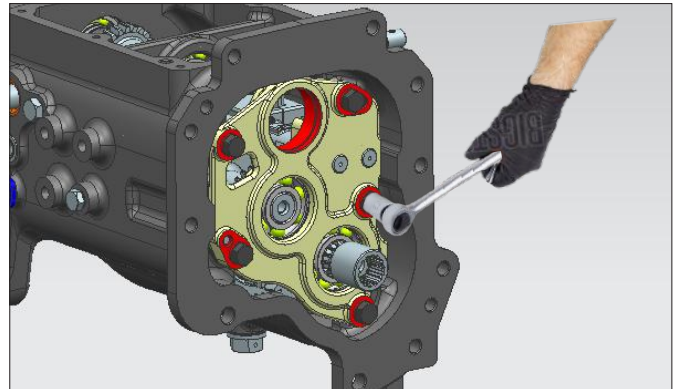

29. Tight the bolts of bearing holder plate.
Torque= 25.81-29.50 lbf.ft (35-40 Nm).

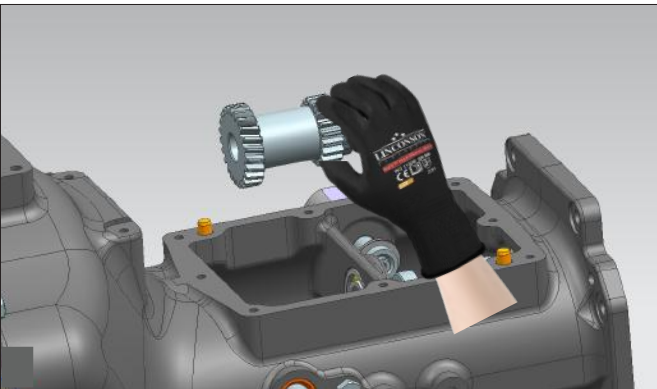

30. Insert the cluster gear.

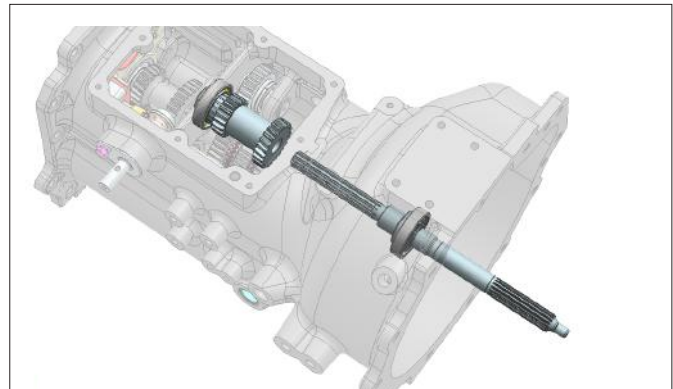

31. Assemble the ball bearing 6007 in clutch housing by using mandrel 9+9 011 and insert the input shaft and cluster gear.

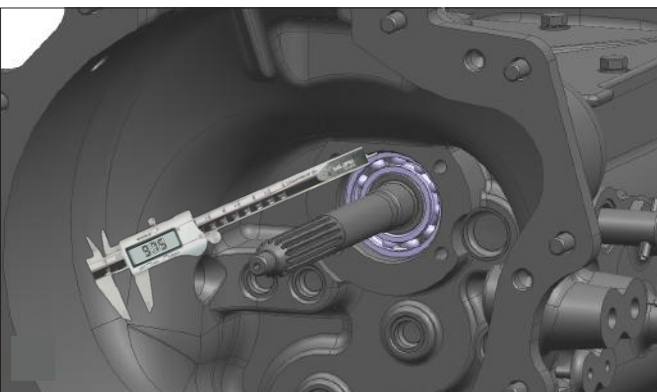

32. Check the gap of housing face to bearing face.
Specified Limit (A)= 9.55-9.65 mm (with shim).

Ex:- Gap housing face to bearing face(B)= 9.75 mm
Required thickness of shim = B - A = 9.75 mm - 9.55 mm
= 0.2 mm

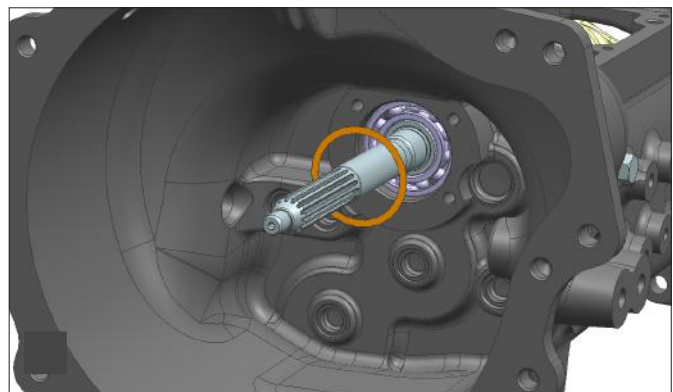

33. Insert the 0.2 mm thickness of shim .

Shim size :- 0.1, 0.2, 0.5 mm

E.4 Assembly of Gear Box

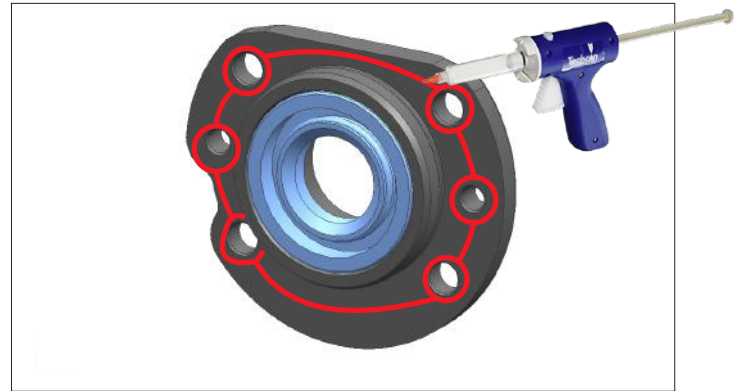
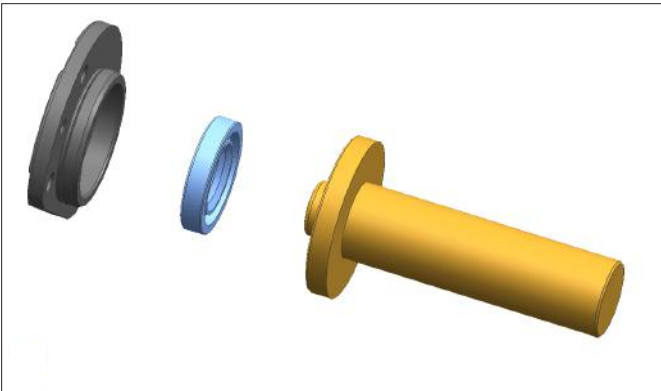

35. Apply sealant (5188) on input shaft retainer.

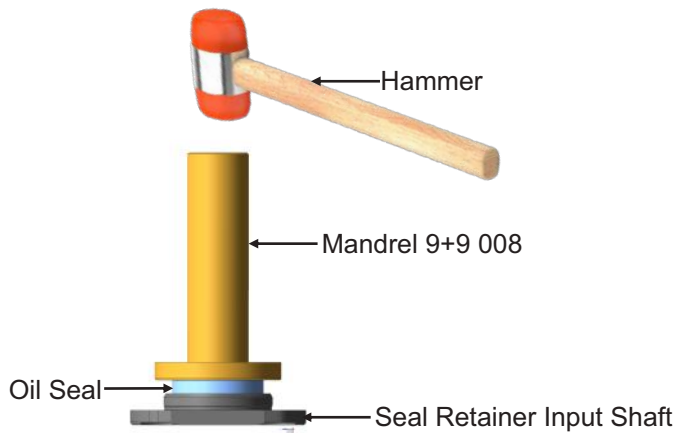

34. Install the oil seal in seal retainer input shaft by using mandrel 9+9 008. plane face of seal towards seal retainer.

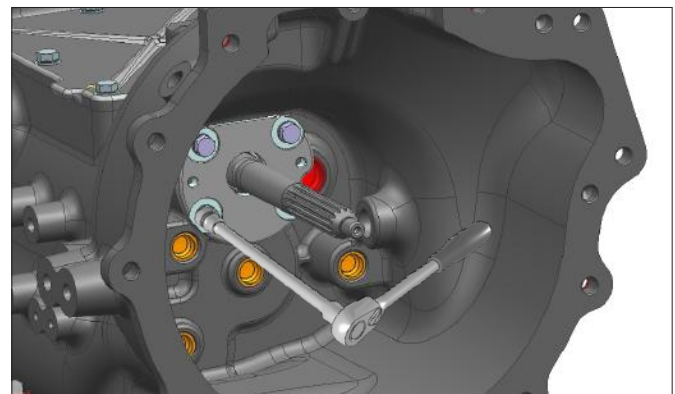

36. Apply loctite 243 on the bolts and tight the bolts of input shaft retainer. Torque= 13.28-16.96 lbf.ft (18-23 Nm) .

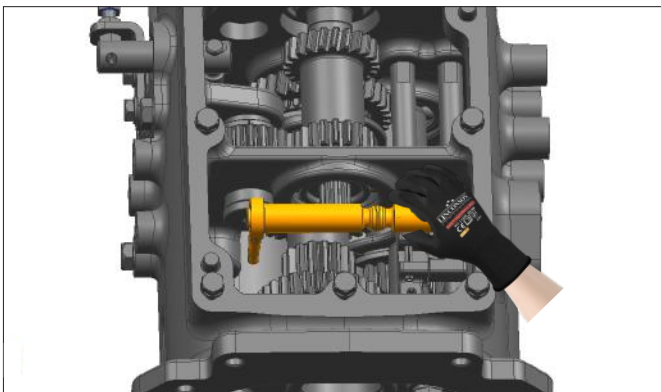

37. Insert the pivot lug.

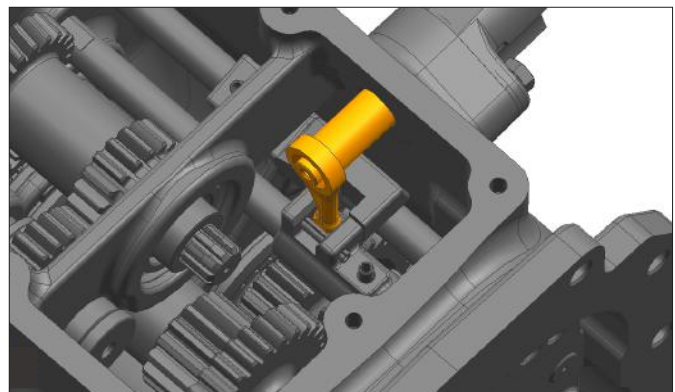

38. Assemble the pivot lug as show in figure.

E.4 Assembly of Gear Box

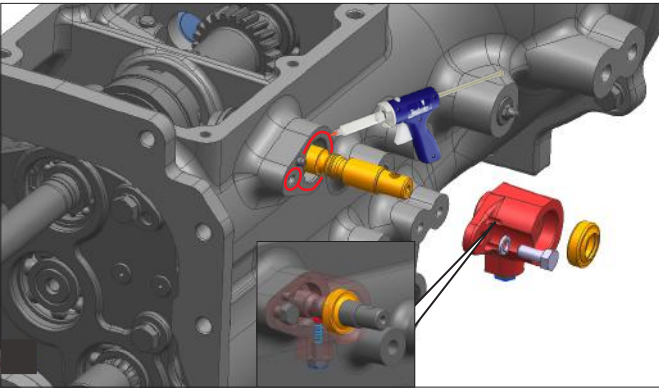

39. Apply sealant (5188) on the mounting hub area, assemble ball and spring in mounting hub and mounting hub and seal fitted on the clutch housing.

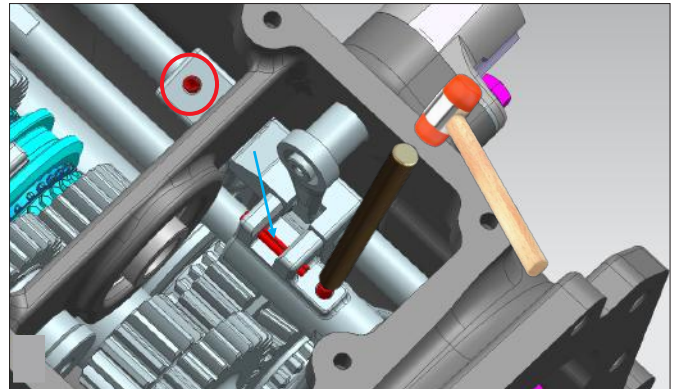

40. Insert the split pins and engage the fork 2ND-3RD and fork 1ST gear with shifter rod to help of mandrel (9+9 003).

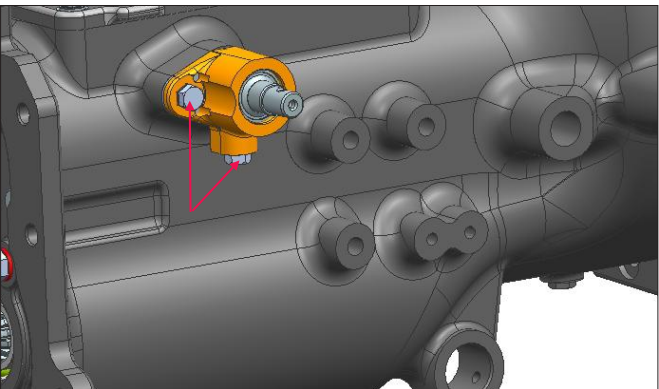

41. Tight the bolt of mounting hub.
Torque= 13.28-16.96 lbf.ft (18-23 Nm).
(loctite 243)

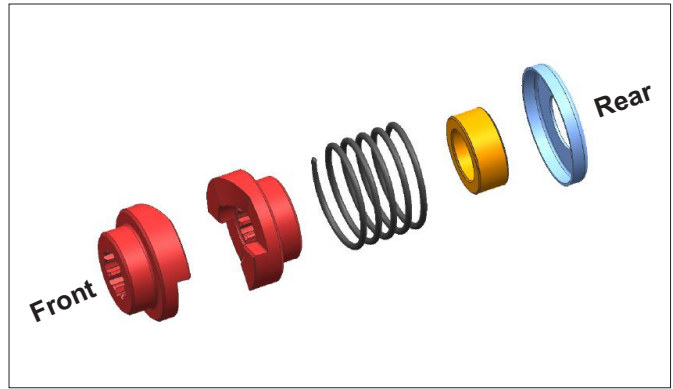

42. Exploded View of PTO Slip Clutch Assembly.

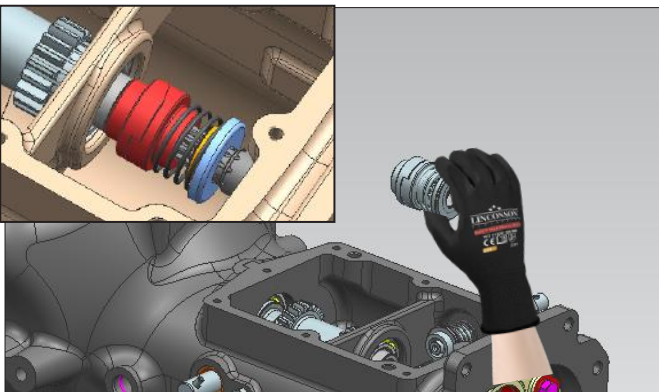

42a. Insert the PTO slip clutch assembly.

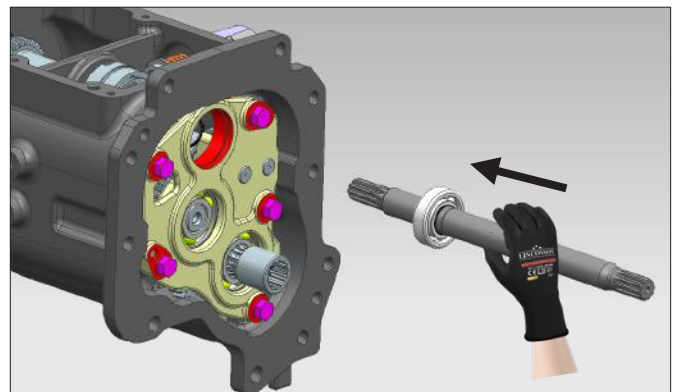

43. Assemble the PTO clutch shaft.

E.4 Assembly of Gear Box

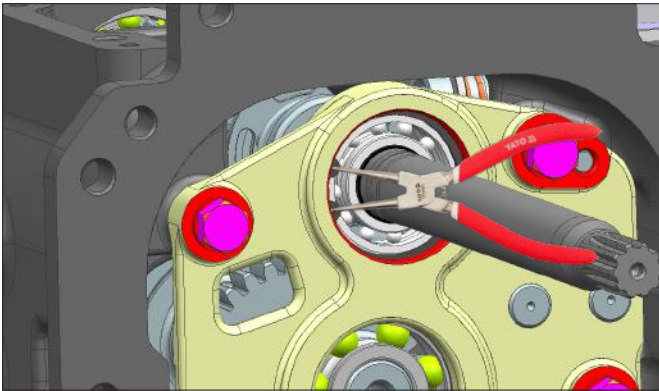

44. Remove the circlip of PTO coupler shaft assembly.

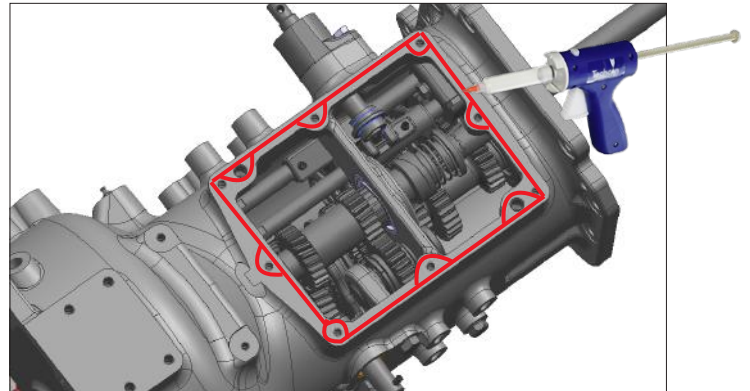

45. Apply the sealant (5188) on the clutch top cover area.

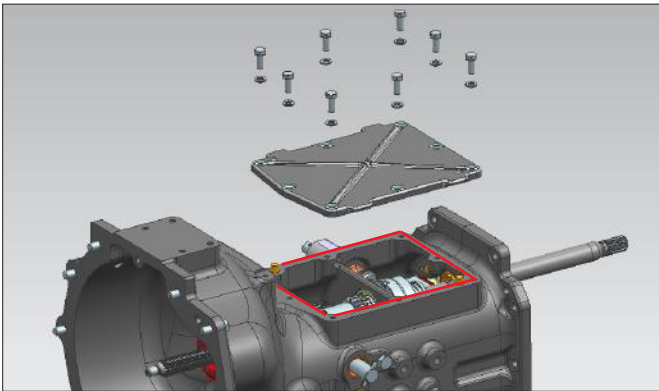

46. Assemble the top cover plate.

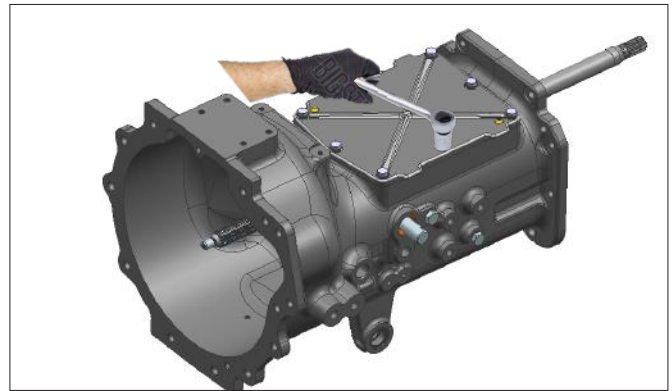

47. Apply loctite 243 on the bolts and tight the bolts of clutch top cover. Torque= 13.28-16.96 lbf.ft (18-23 Nm)

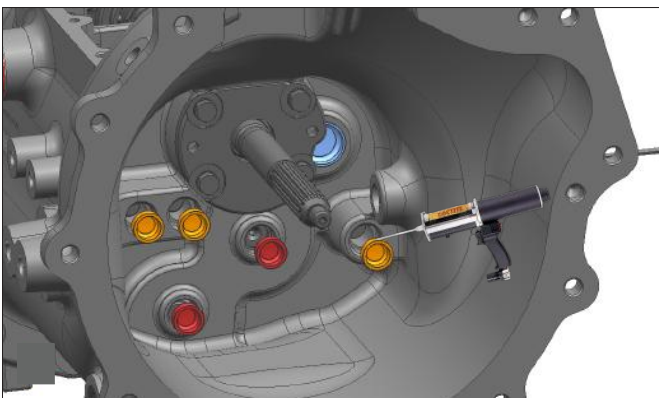

48. Apply loctite 243 on the clutch housing all cap.

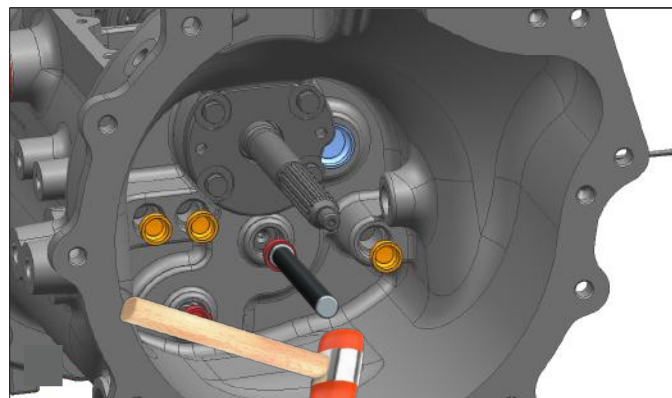

49. Press the all cap in clutch housing to help of mandrel (9+9 009, 9+9 010).

E.4 Assembly of Gear Box

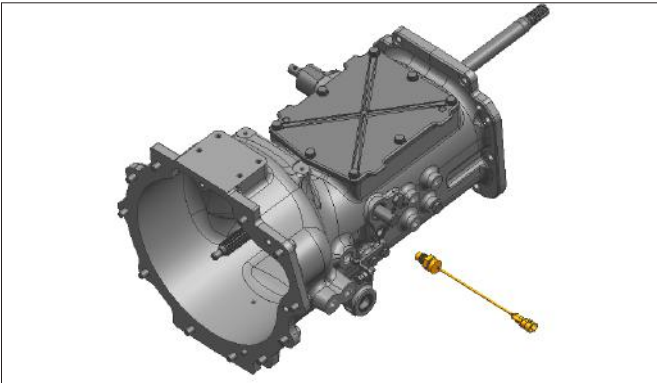

50. Assemble the neutral switch.

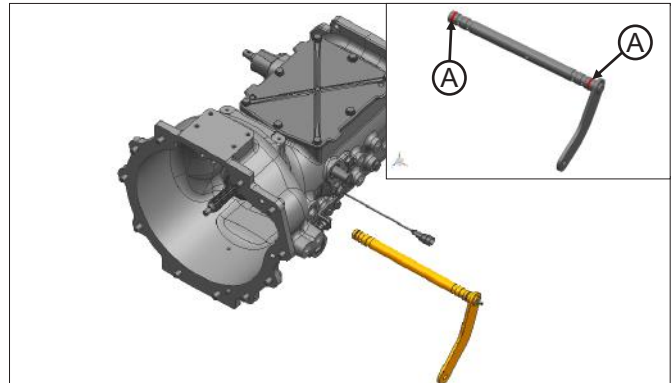

51. O-ring (A) assemble in clutch lever and insert the clutch lever shaft and CRB fork.

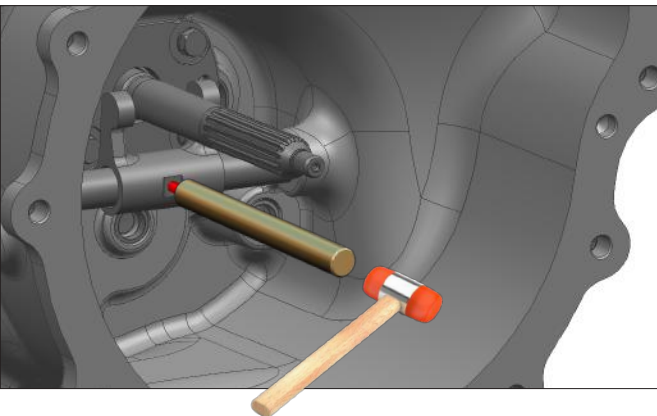

52. Engage the split pin of fork clutch.

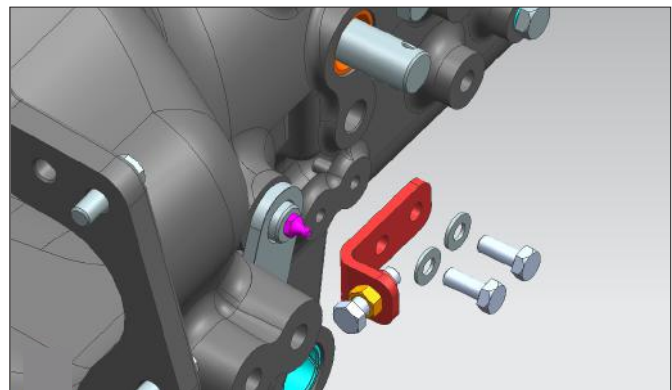

53. Assemble the clutch stopper bracket.

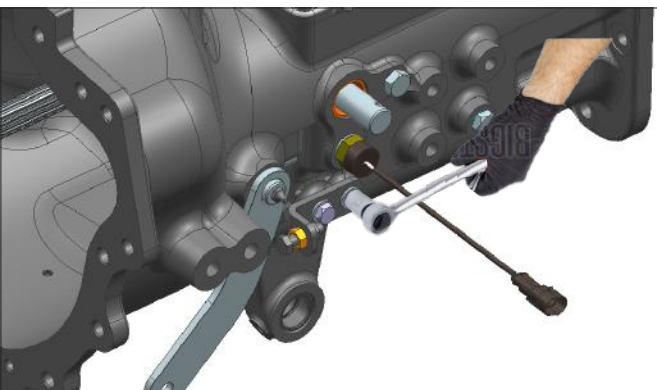

54. Apply loctite 243 on the bolts and tight the bolts of clutch stopper bracket. Torque= 13.28-16.96 lbf.ft (18-23 Nm).

Assembly of Differential & Rear Axle housing

CONTENTS

REF. NO	DESCRIPTION	PAGE
A.5	Torque Chart-Differential Housing	74
B.5	Assembly of Cage Sub Assembly	75-77
C.5	Assembly of Tail Pinion Shaft	78-80
D.5	Assembly of Range Lay Shaft	81
E.5	4WD Shaft Sub Assembly	82-83
F.5	Rear PTO Assembly	84-87
G.5	Assembly of Trumpet Housing	88-90
H.5	Assembly of Differential Housing	91-103
I.5	Differential Backlash Adjustment	98
J.5	Troubleshooting	104-105

A.5 Torque Chart-Differential Housing

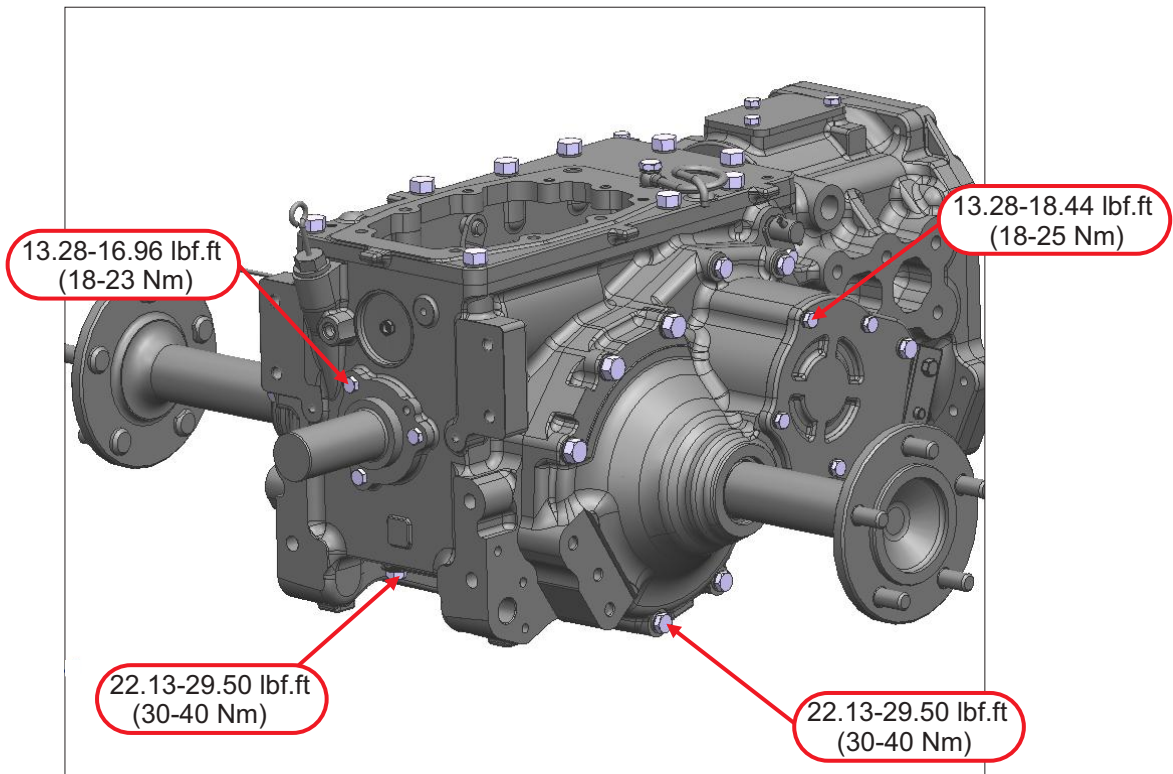
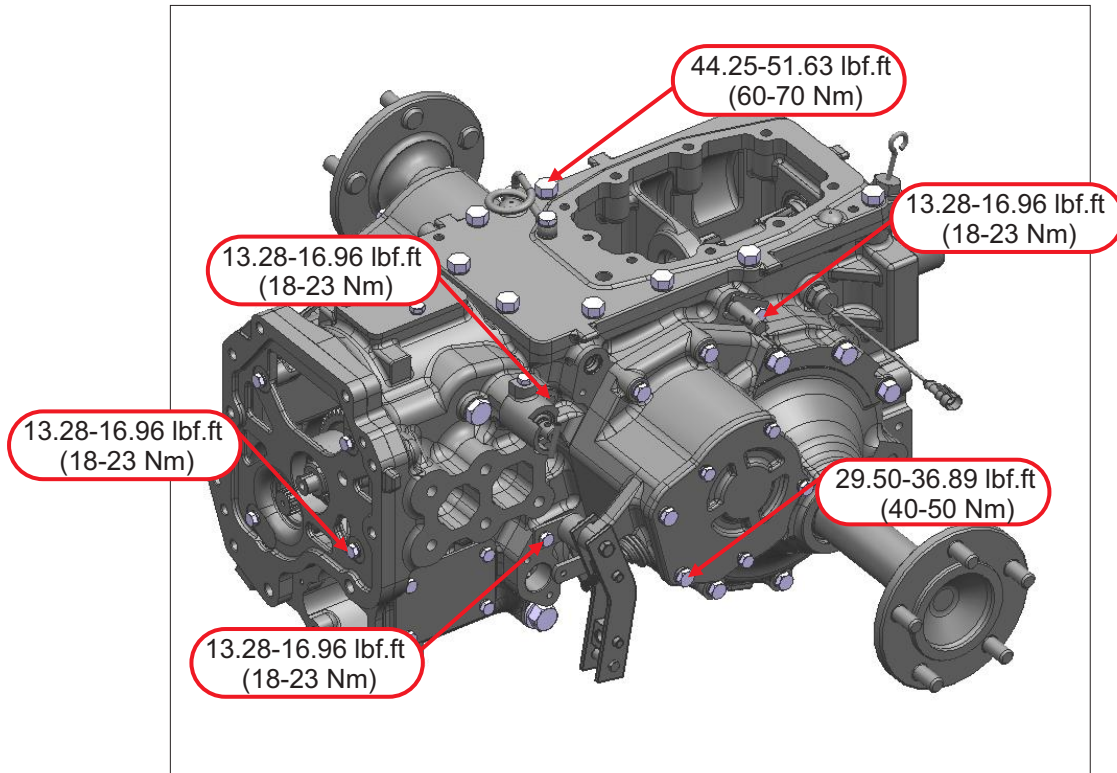

B.5 Differential Sub Cage Assembly

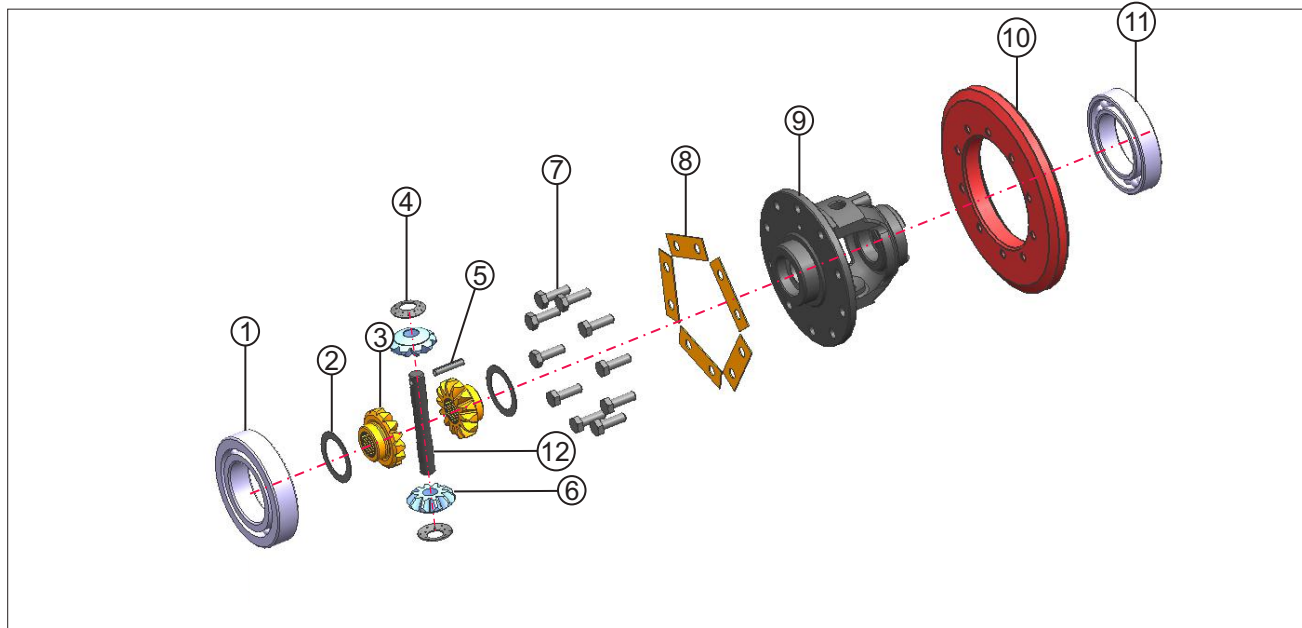
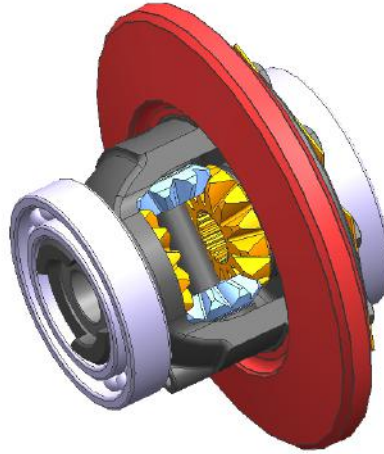

1	Ball Bearing 6011
2	Diff Side Gear Liner
3	Diff. Side Gear 14T
4	Thrust Washer
5	Spring Cotter Sleeve
6	Diff Pinion Gear 10T

7	Bolt
8	Locking Washer
9	Diff Cage Assembly
10	Crown Wheel
11	Ball Bearing 6211
12	Pinion Shaft

B.5 Differential Sub Cage Assembly

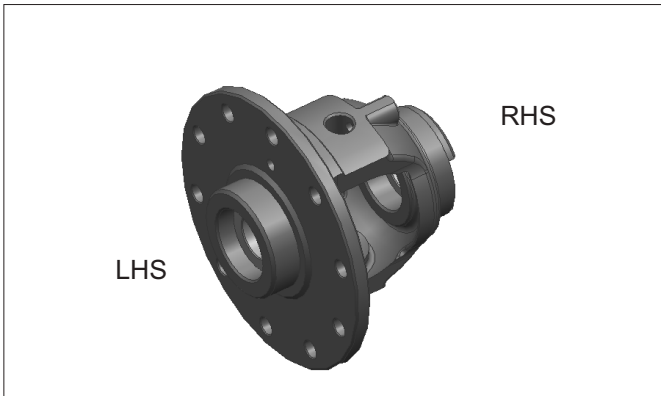

a. Take the differential cage.

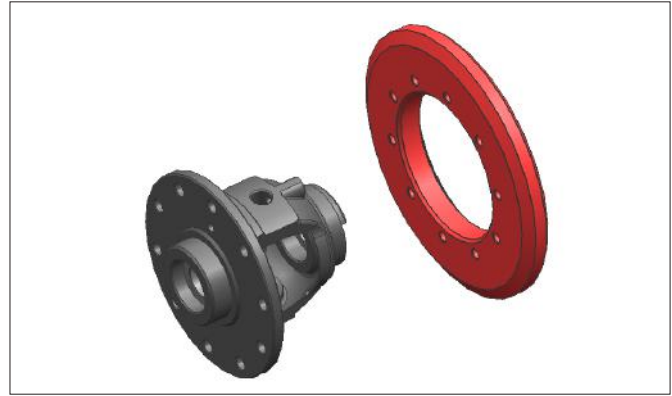

b. Assemble the crown wheel in RHS of differential cage. Plain face of the crown wheel towards cage side.

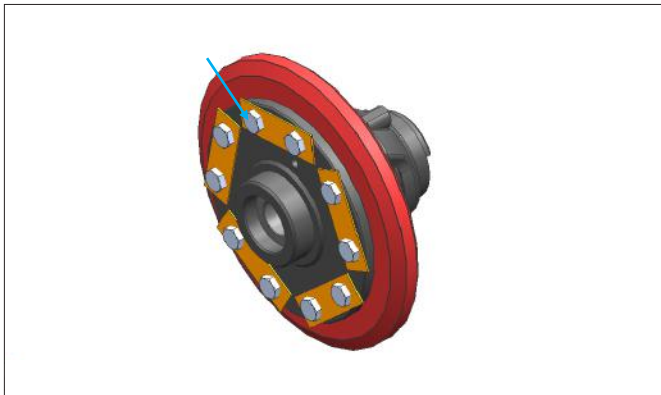

c. Tight the bolts of diff. cage and lock the locking strip. Torque= 13.28-16.96 lbf.ft (18-23 Nm). Loctite 243

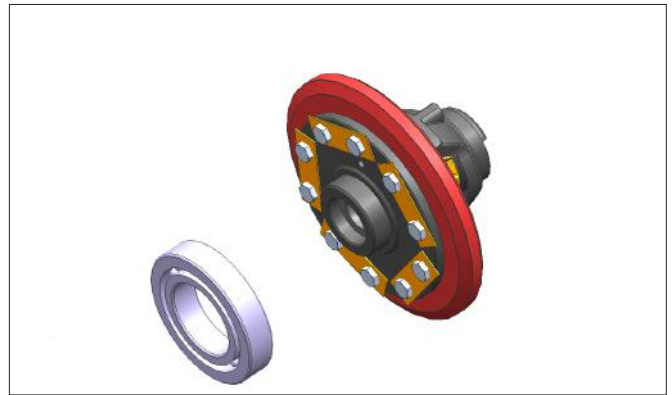

d. Press the LHS ball bearing 6211 on the differential cage by using mandrel.

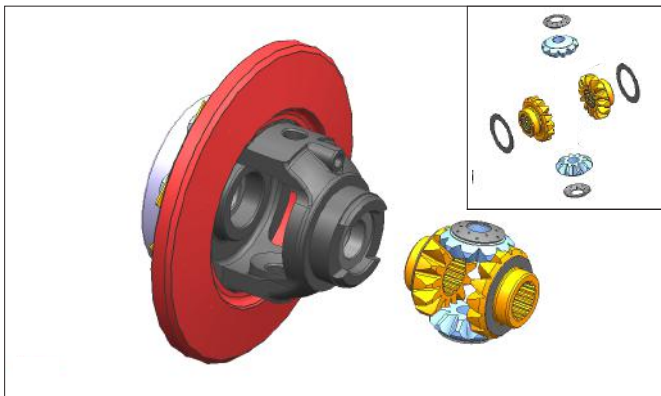

e. Assembly differential side gear.

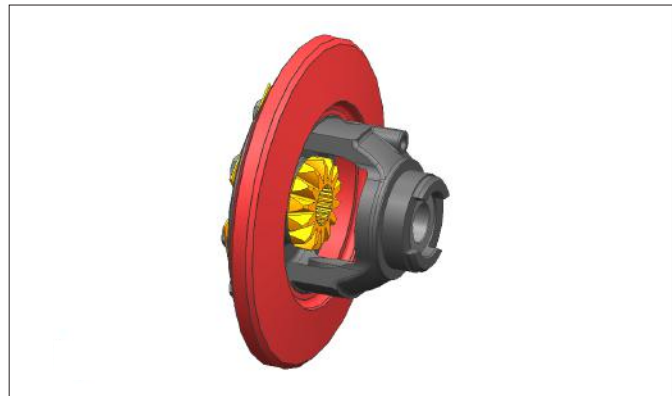

f. Assemble the inner and outer gear with liner.

B.5 Differential Sub Cage Assembly

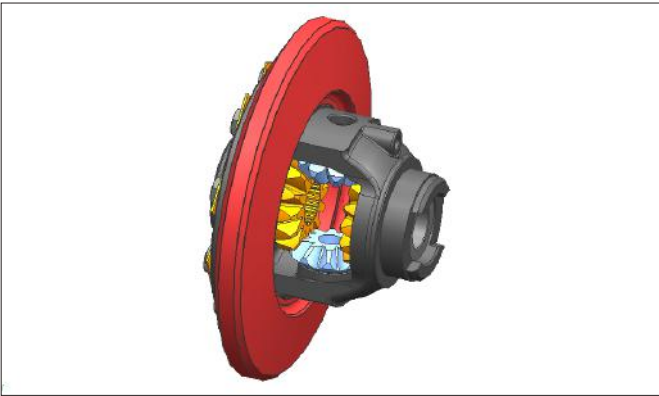

g. Assemble the second differential pinion gear with thrust washer.



h. Insert the pinion shaft.

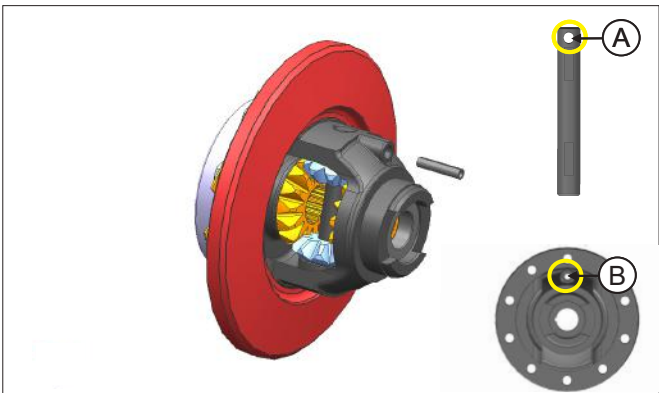

i. Align the hole (A) of shaft with hole (B) end. Press the sleeve by using hammer.

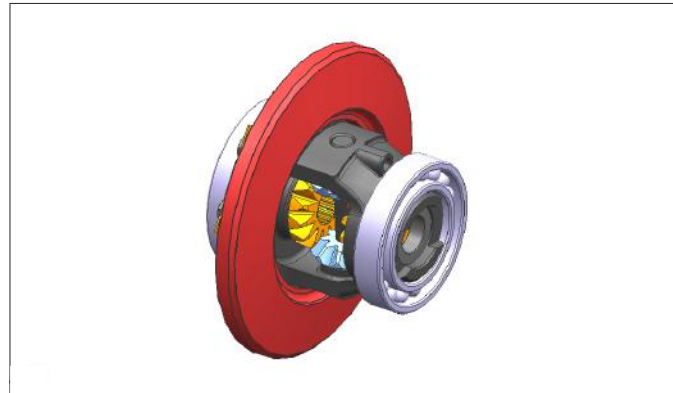

j. Assemble ball bearing 6011 on the RHS differential cage by using mandrel.

C.5 Assembly of Tail Pinion Shaft

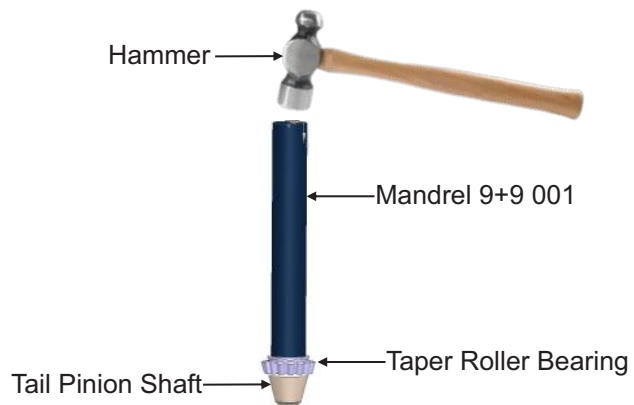

1. Install the taper roller bearing by using mandrel 9+9 001.



2. Insert the spacer.

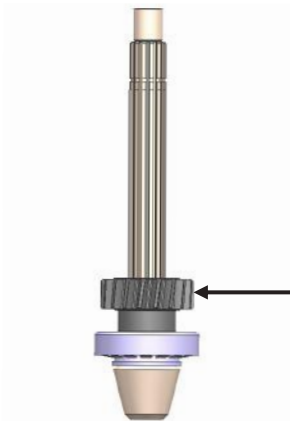

3. Insert the driver gear 4WD.

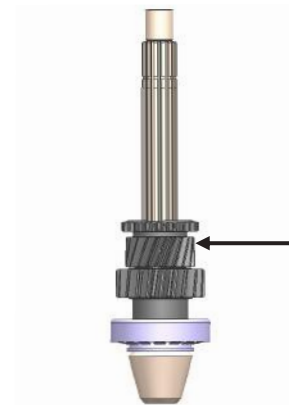

4. Insert the dog gear high.

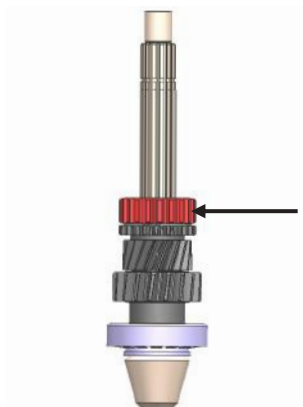

5. Insert the hub.

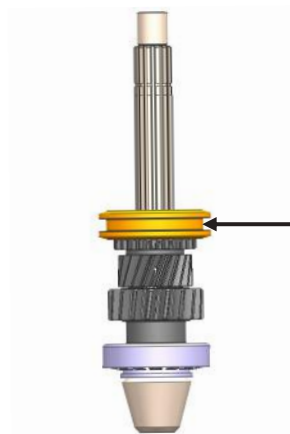

6. Insert the shifter sleeve.

C.5 Assembly of Tail Pinion Shaft

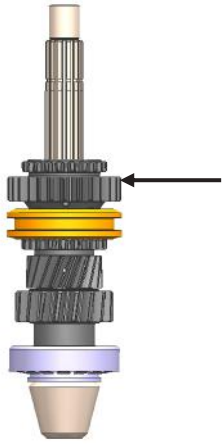

7. Insert dog gear medium.

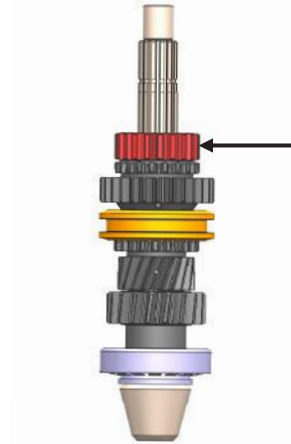

8. Insert the hub.

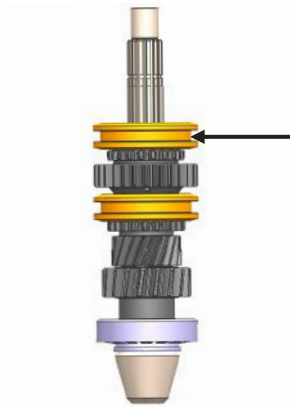

9. Insert the shifter sleeve.

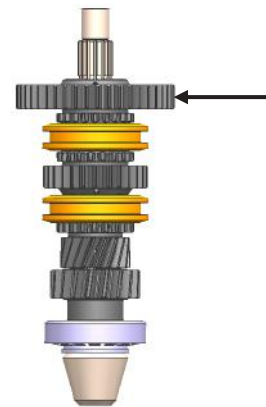

10. Insert the dog gear low.



11. Insert the thrust washer.

C.5.a Procedure of Shim Selection for Tail Pinion Shaft :

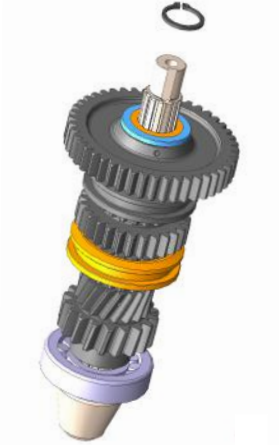

Step.1 : Assemble the circlip and lock the tail pinion shaft.



Step.3 : Remove the circlip. Insert the shims as per required. Reassemble the circlip at its position.

Shim selection process :-

Example :

Clearance between spacer and dog gear low = 0.25 mm (A)

Specified limit = 0.10-0.15 mm (B)

Required shim thickness = A - B

$$= 0.25 - 0.10$$

$$= 0.15 \text{ mm}$$

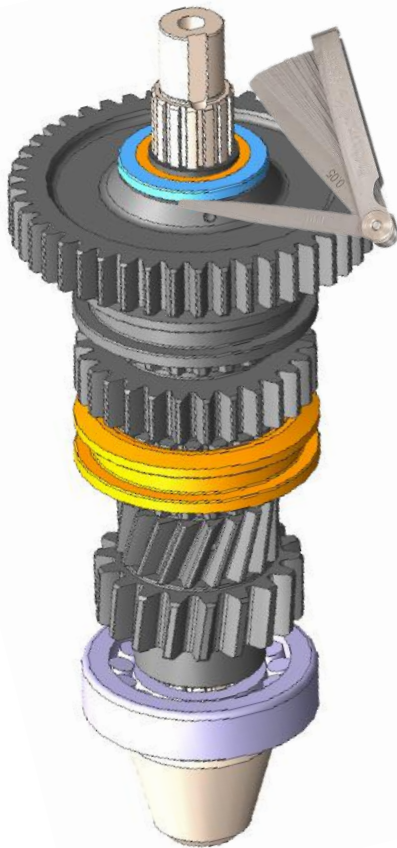

Step.2 : Measure the clearance between spacer and dog gear low.

D.5 Assembly of Range Lay Shaft



a. Insert the needle roller bearing.



b. Insert the idler gear 4WD.



c. Insert the spacer.

E.5 4WD Shaft Sub Assembly

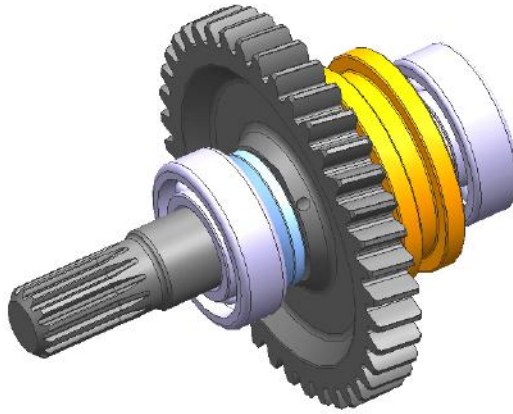

Exploded View

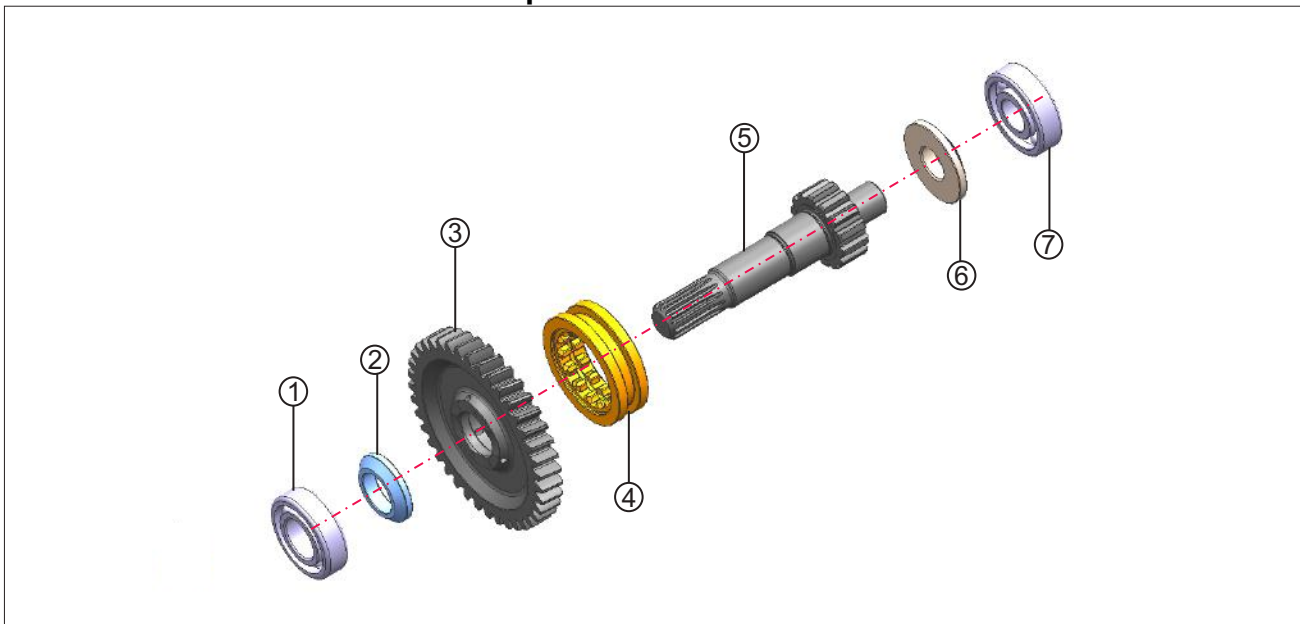

1	Ball Bearing 6205
2	Spacer
3	Driven Gear 4WD
4	Shifter Sleeve
5	4WD Output Shaft
6	Spacer
7	Ball Bearing 6304

E.5 4WD Shaft Sub Assembly



a. Insert the spacer.



b. Insert the ball bearing 6304.



c. Insert the driven gear 4WD.



d. Insert the spacer.

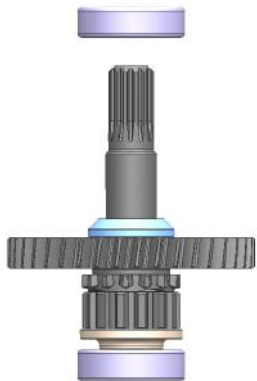

e. Insert the ball bearing 6205.

F.5 Rear PTO Assembly

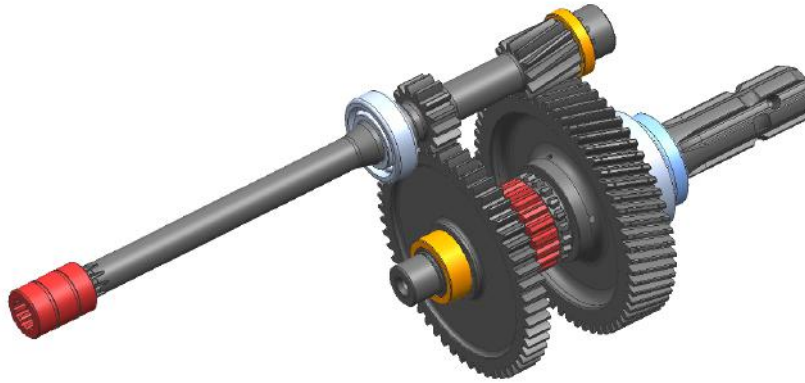

Exploded View

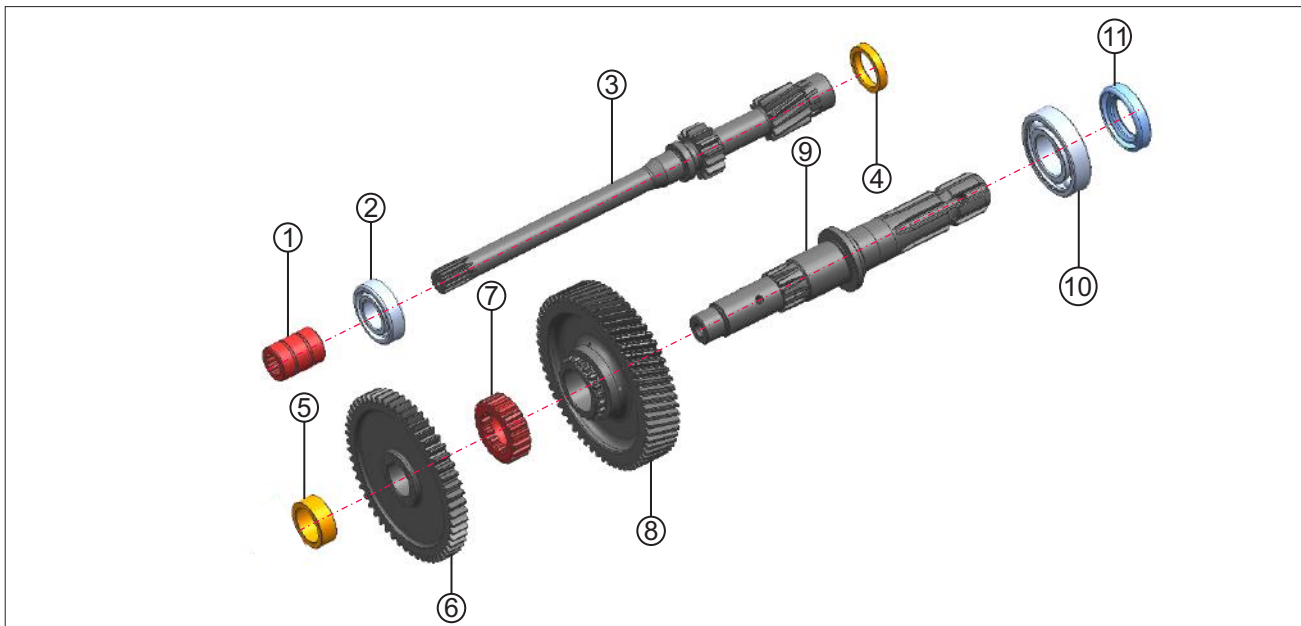

1	Connecting Sleeve PTO
2	Ball Bearing 6205
3	PTO Intermediate Shaft
4	Spacer
5	Spacer
6	PTO Gear Z-54
7	Hub

8	PTO Gear Z-59
9	Rear PTO Output Shaft
10	Ball Bearing 6207
11	Oil Seal

F.5 Rear PTO Shaft Assembly



a. Take PTO intermediate shaft.



b. Insert the spacer.

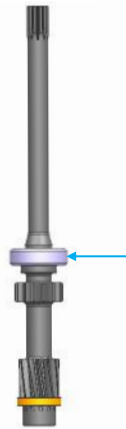

c. Press fitted the ball bearing 6205.



d. Assemble the connecting sleeve PTO.



e. Lock the circlip.

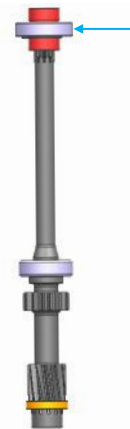

f. Insert the ball bearing.

F.5 Rear PTO Shaft Assembly



g. Lock the circlip.

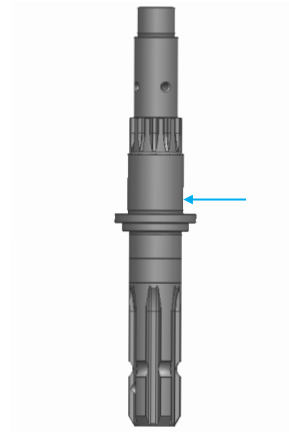

h. Take rear PTO output shaft.

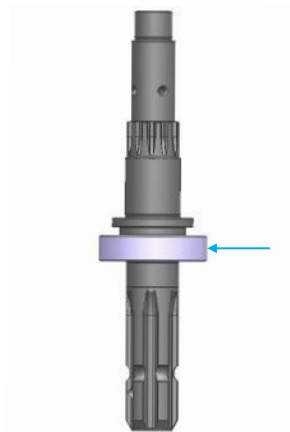

i. Press fitted the ball bearing 6207.

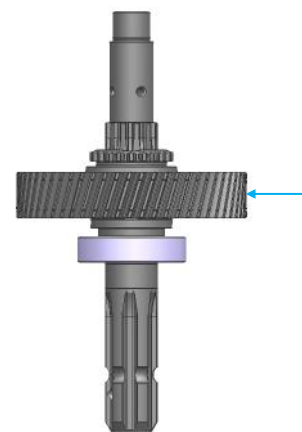

j. Insert the PTO gear Z-59.

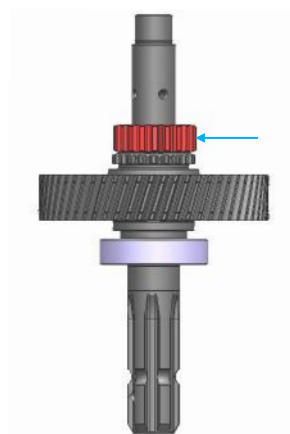

k. Insert the hub.

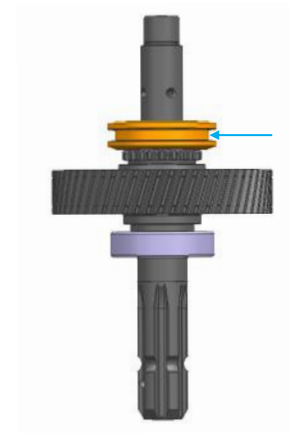

l. Insert the shifter sleeve.

F.5 Rear PTO Shaft Assembly

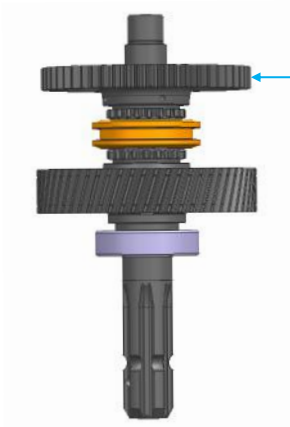

m. Insert the PTO gear Z-54.



n. Insert the spacer.

G.5 Assembly of Trumpet Housing

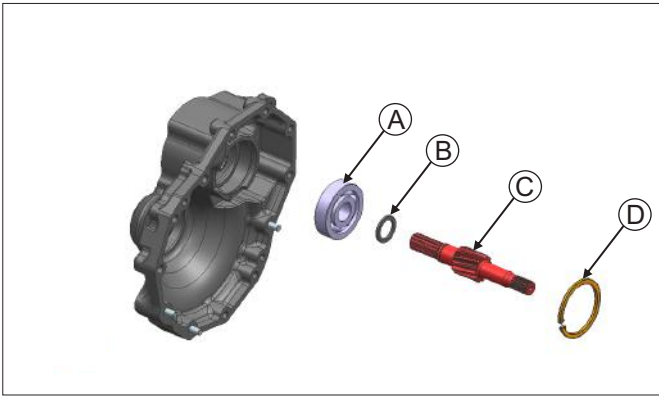

1. Assemble ball bearing 6406 (A) in trumpet housing by using mandrel 18ME248 and insert spacer (B), bull pinion shaft (C).

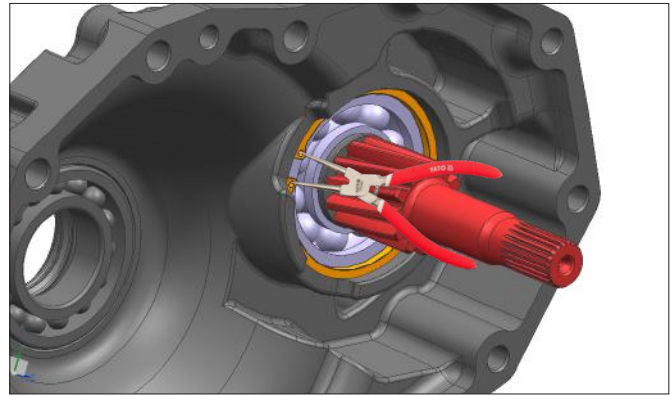

2. Lock the external circlip (D).

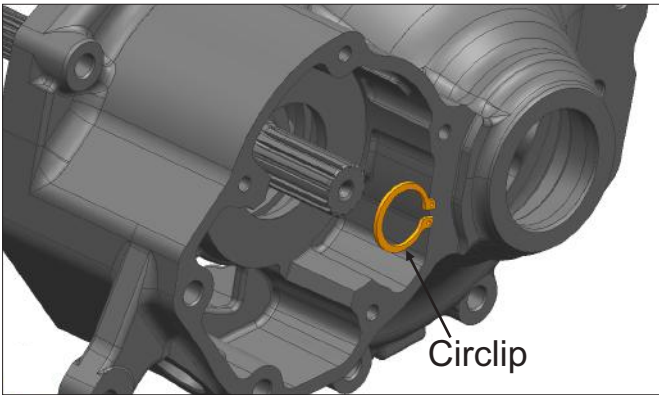

3. Lock the internal circlip.

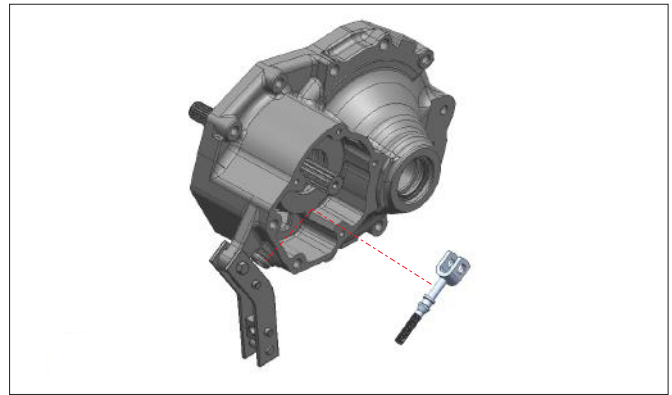

4. Assemble the brake actuating shaft.

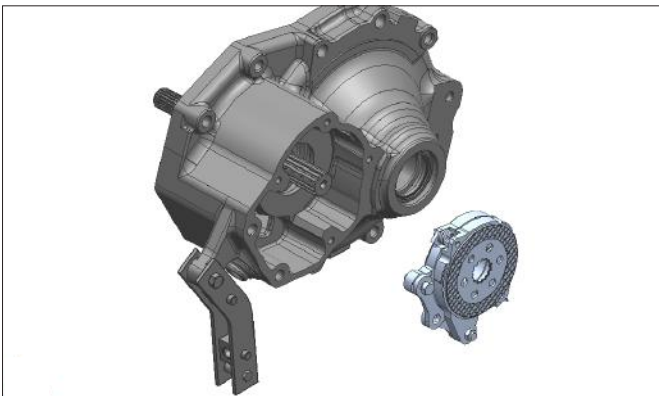

5. Insert the brake assembly.

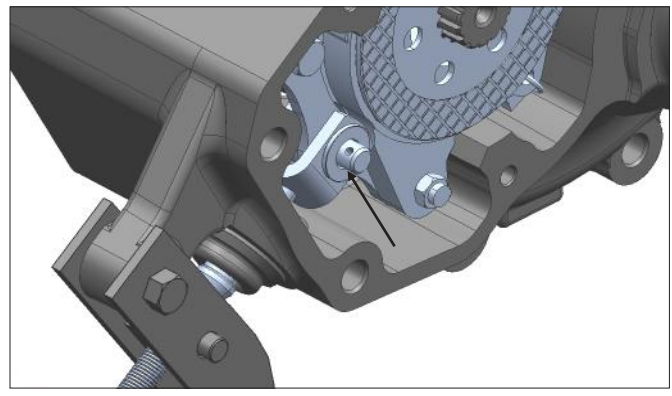

6. Insert the bolt in brake assemble and engage with brake actuating shaft.

G.5 Assembly of Trumpet Housing

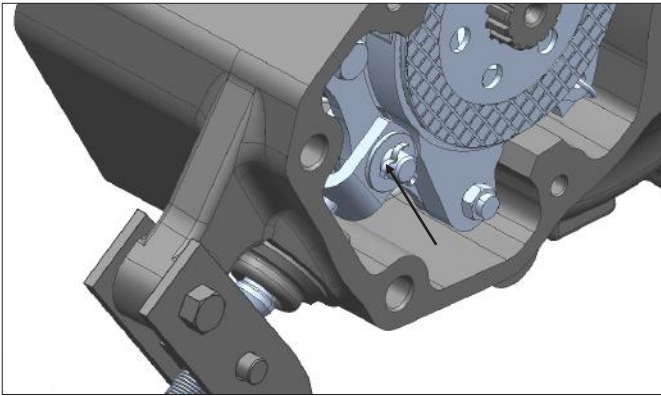

7. Insert the cotter pin.

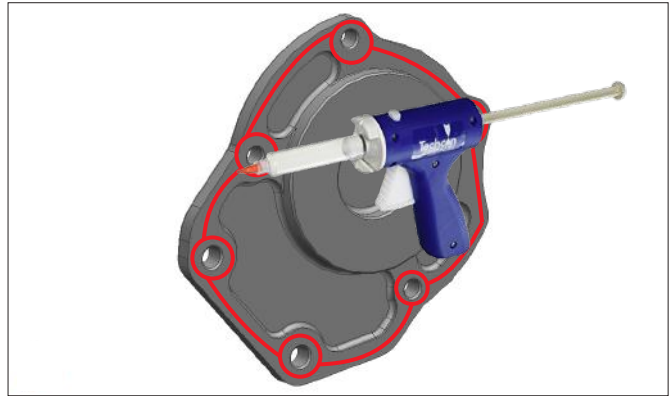

8. Apply sealant 5188 on the brake cover.

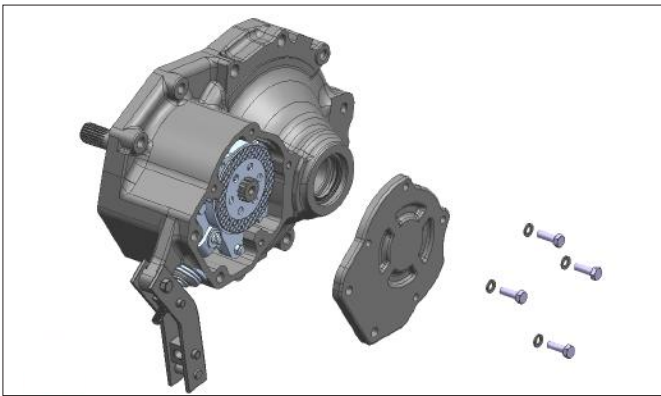

9. Apply loctite on the bolts and tight the bolts of brake cover.(loctite 243)
Torque= 13.28-18.44 lbf.ft (18-25 Nm).

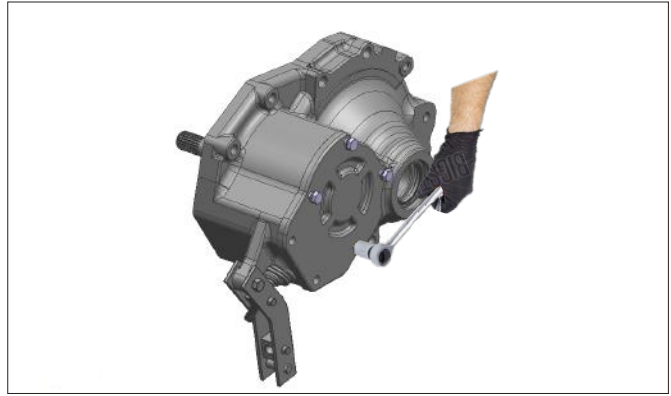

10. Assemble the brake cover.

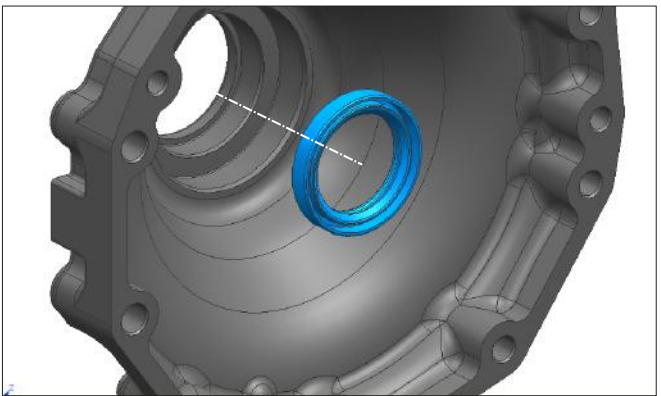

11. Assemble the oil seal in brake housing by using mandrel 18ME252 .

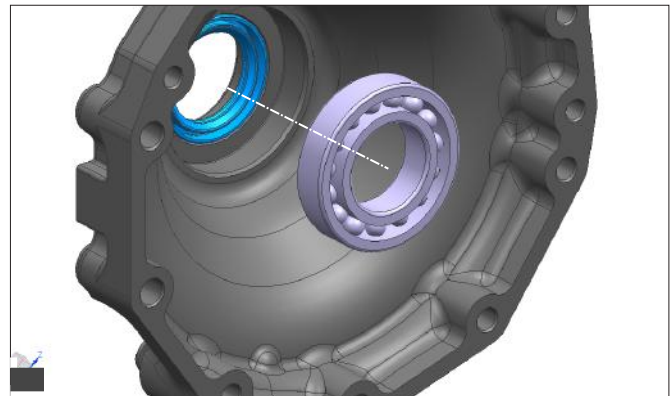

12. Assemble the ball bearing 6209 in brake housing.

G.5 Assembly of Trumpet Housing

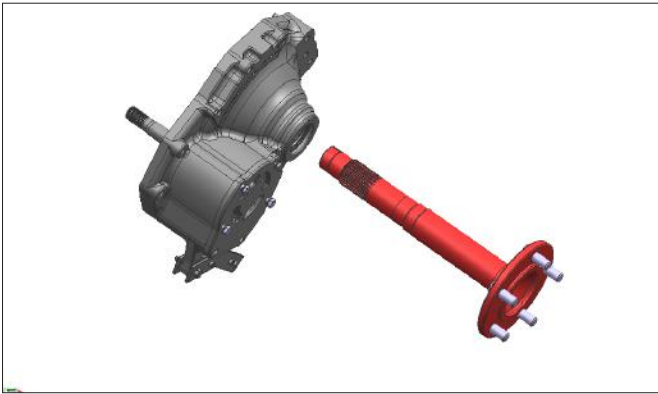

13. Assemble the rear axle.

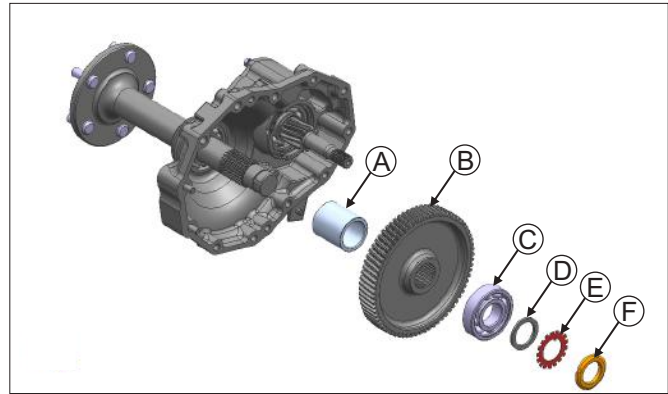

14. Insert the spacer (A), bull gear (B) and assemble ball bearing 6308 (C) by using mandrel HST 07 . Insert spacer(D), lock washer (E).

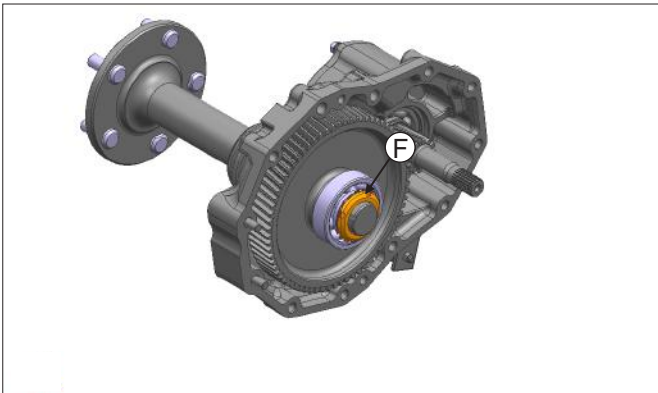

15. Tight the locking nut (F) by using tool 18ME235.
Torque= 44.25-51.63 lbf.ft (60-70 NM)

H.5 Assembly of Differential Housing

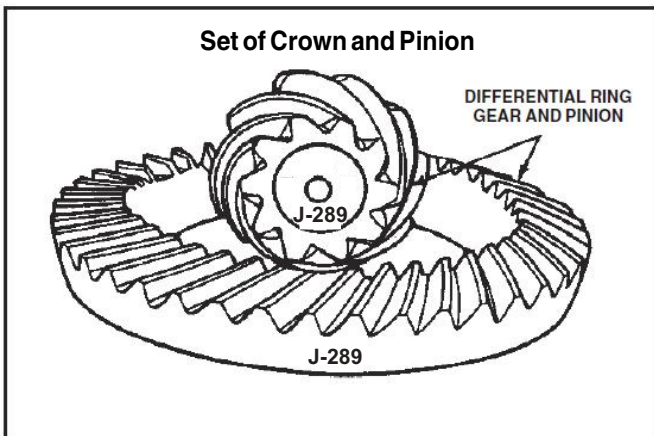

Ring gear and pinion are supplied in matched sets only. Matching numbers on both pinion and ring gear are etched for verification. If a new gear set is being used, verify the numbers of each pinion and ring before proceeding with assembly.

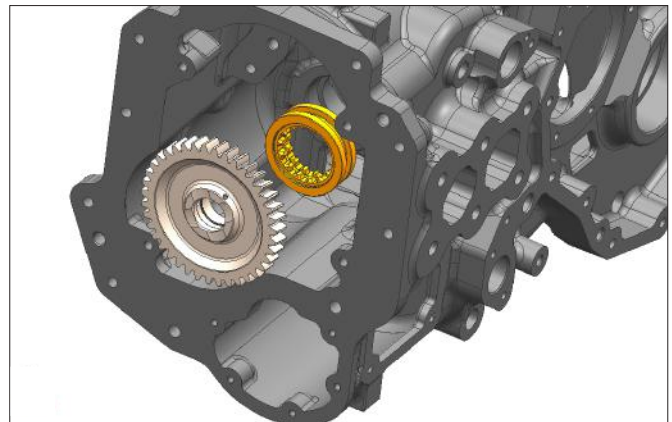

1. Insert 4WD gear and shifter sleeve.

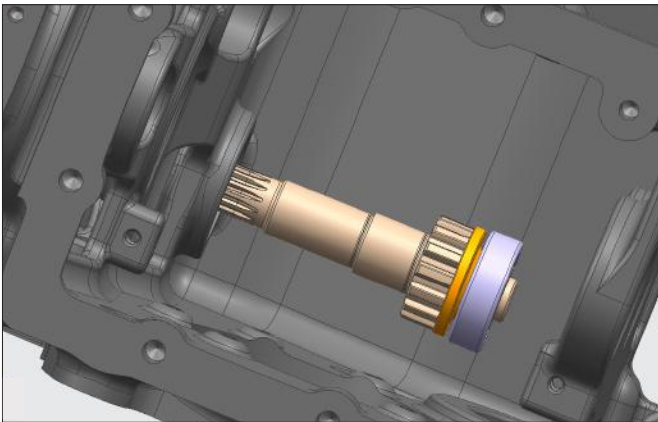

2. Assemble 4WD output shaft, spacer and ball bearing 6304.

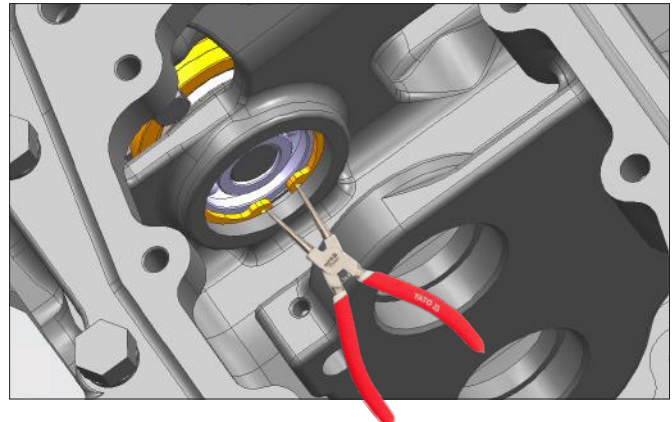

3. Lock the circlip.

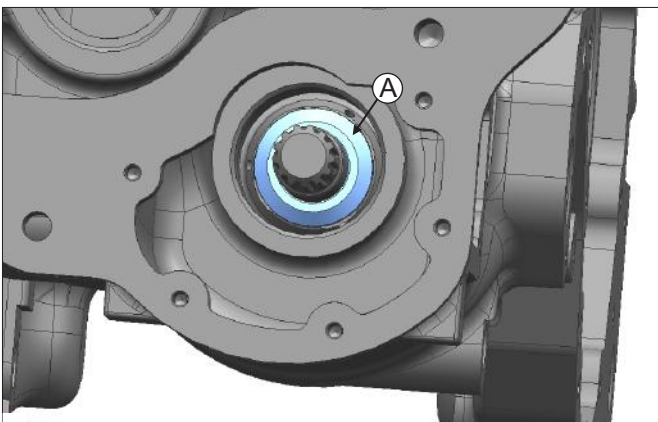

4. Insert the spacer (A) in 4WD shaft.

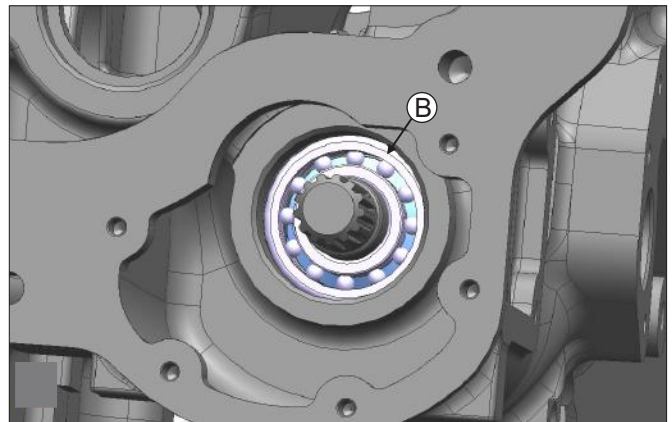

5. Assemble the ball bearing (B) by using mandrel 18ME251.

H.5 Assembly of Differential Housing

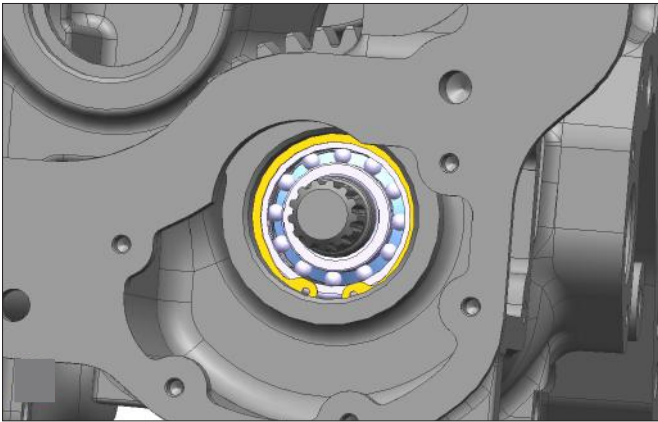

6.Lock the circlip.

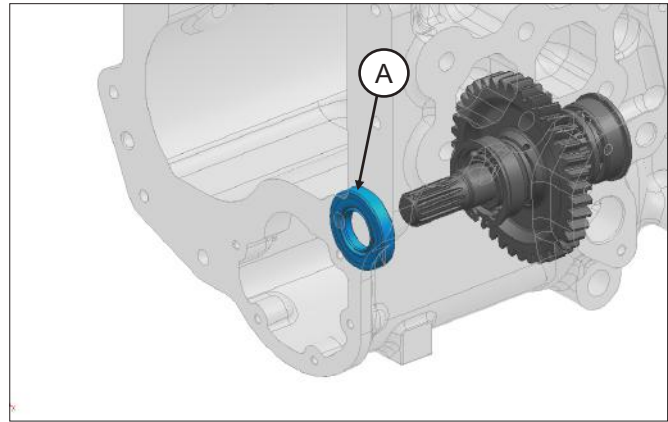

7.Assemble 4WD seal (A) by using mandrel 18ME251.

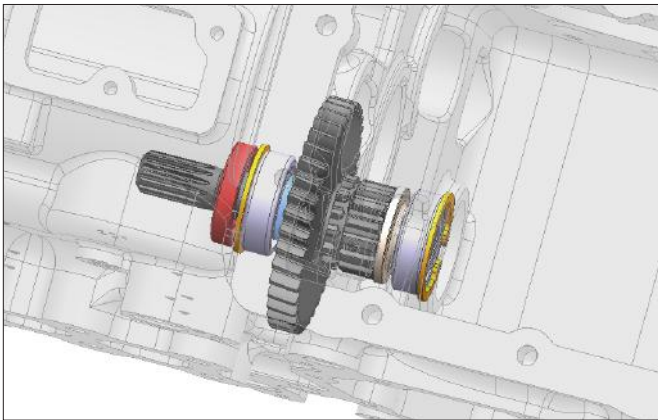

8.Assemble 4WD shaft sub assembly as show in fig.

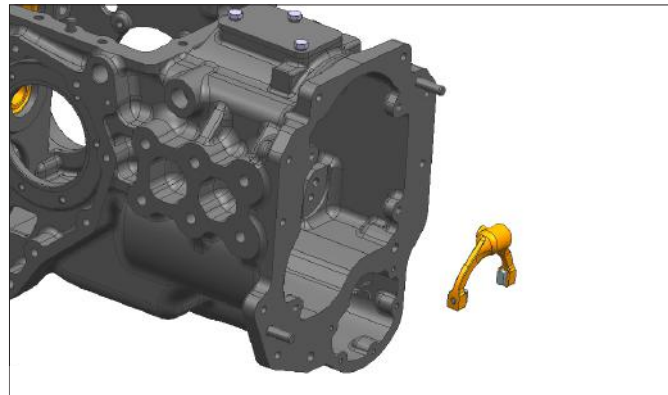

9.Insert the fork 4WD.

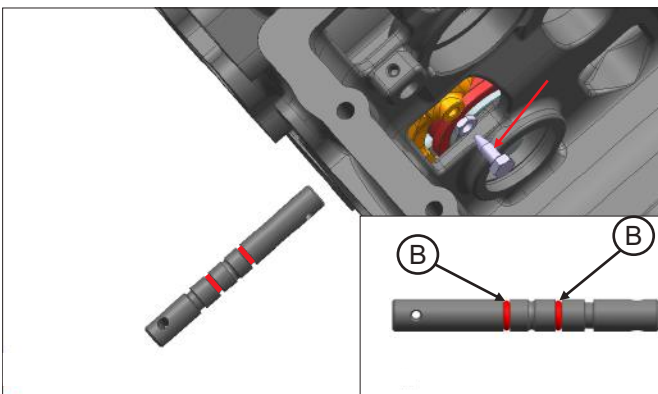

10.Assemble o-ring (B) in the 4WD pivot rod and insert in 4WD fork. Tight the bolt of 4WD fork.
Torque=13.28-16.96 lbf.ft (18-23 Nm).

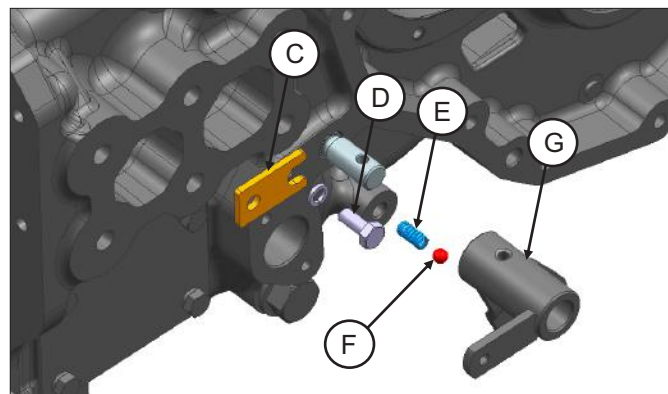

11.Assemble the ball (F), spring (E) ,4WD pivot lug (G) and locking strip (C) and apply loctite on the Bolt (C) and tight the bolt. Torque= 13.28-16.96 lbf.ft (18-23 Nm) (loctite 243)

H.5 Assembly of Differential Housing

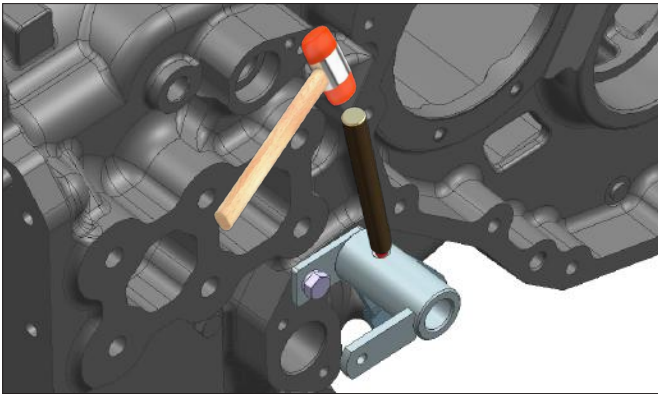

12. Engage the cotter sleeve of 4WD pivot rod by using mandrel.

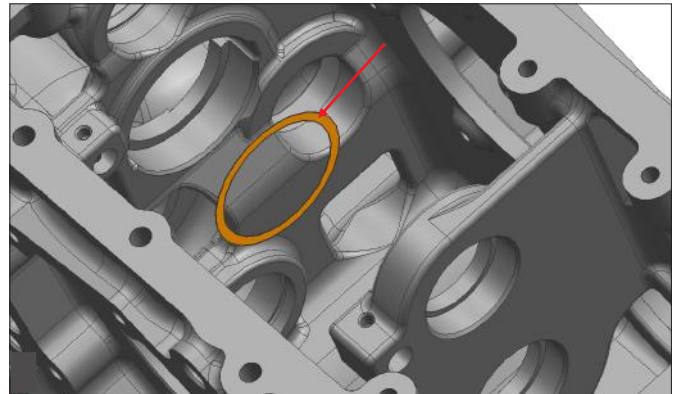

13. Insert the shim as per requirement in taper roller bearing slot.

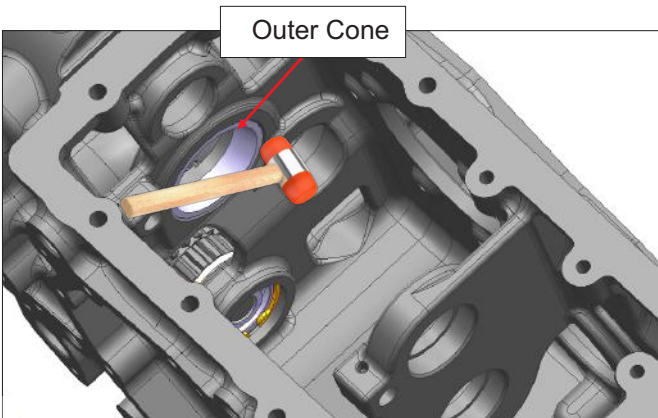

14. Assemble the outer cone of taper roller bearing.

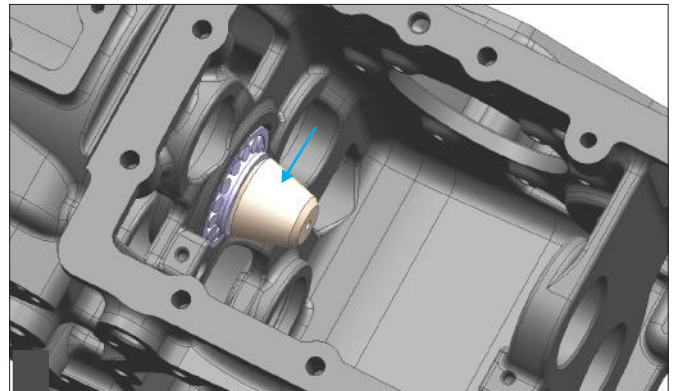

15. Assemble the tail pinion shaft in differential housing.

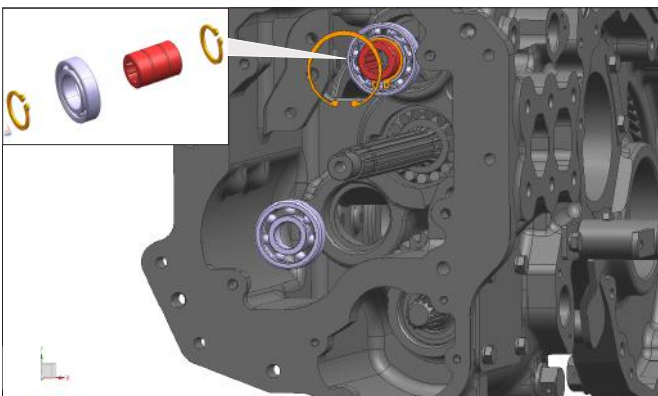

16. Assemble the ball bearing 6304 in differential housing by using mandrel 18ME249. Assemble the connecting sleeve PTO with bearing in differential housing. Install internal circlip in differential housing.

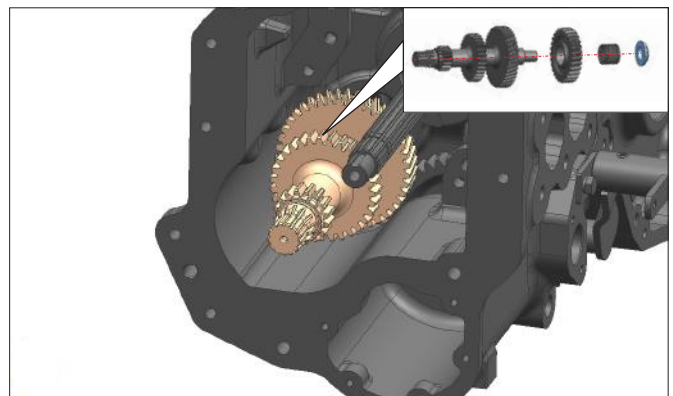

17. Insert the range lay shaft assembly.

H.5 Assembly of Differential Housing

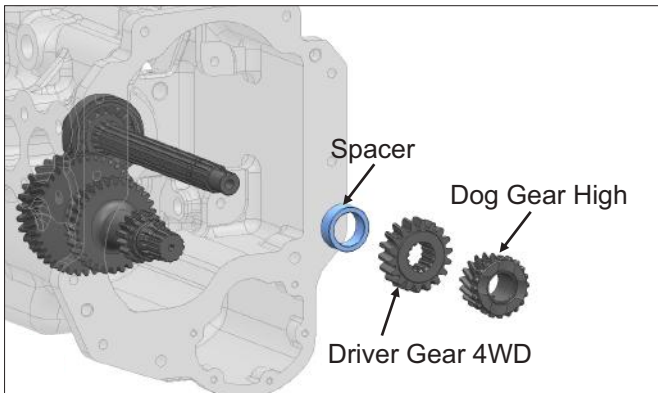

18. Insert the spacer, driver gear 4wd and dog gear high.

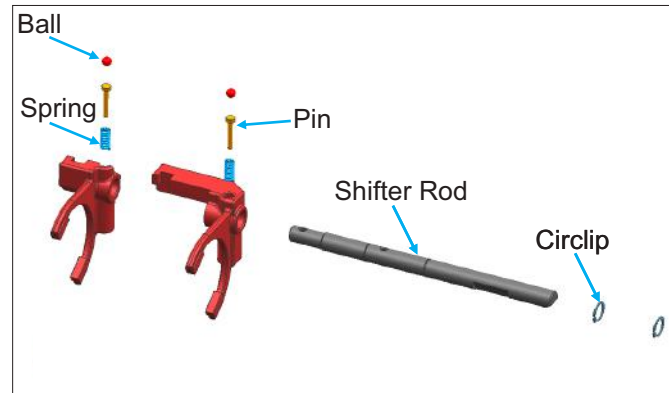

19. Exploded view of fork assembly.

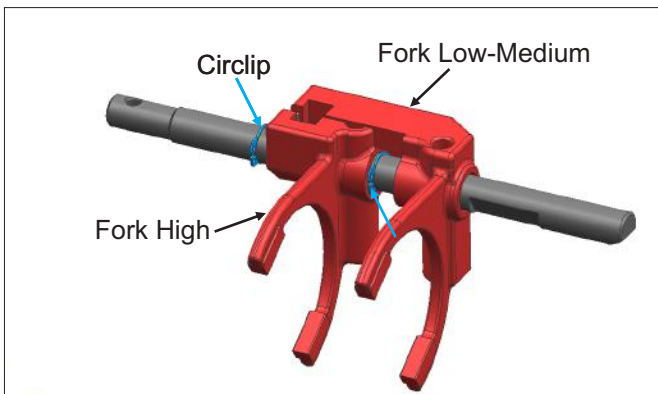

19a. Insert fork low-medium and fork high in shifter rod and assemble the circlip as shown in figure.

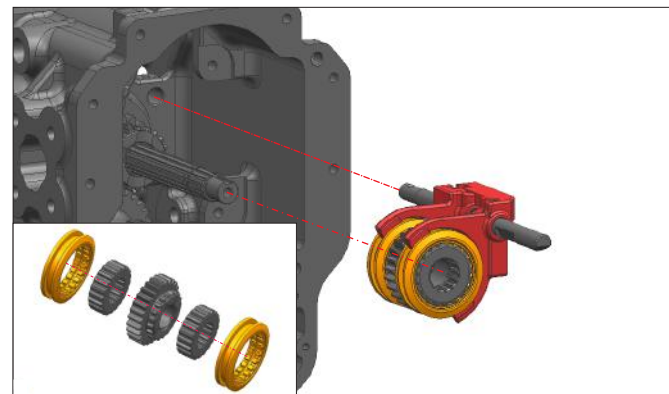

20. Insert the shifter sleeve and hub, dog gear medium and Shifter fork and rod assembly.

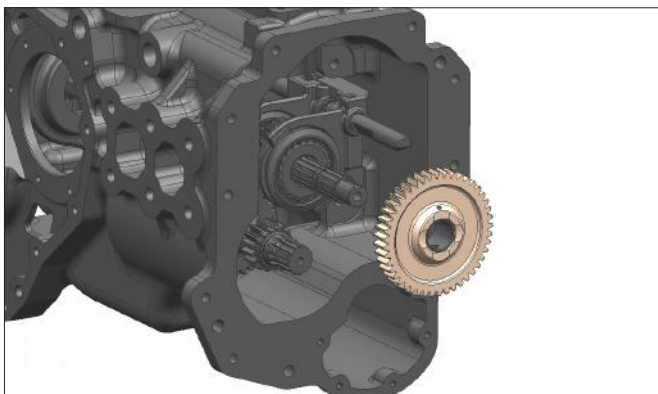

21. Insert the dog gear low.

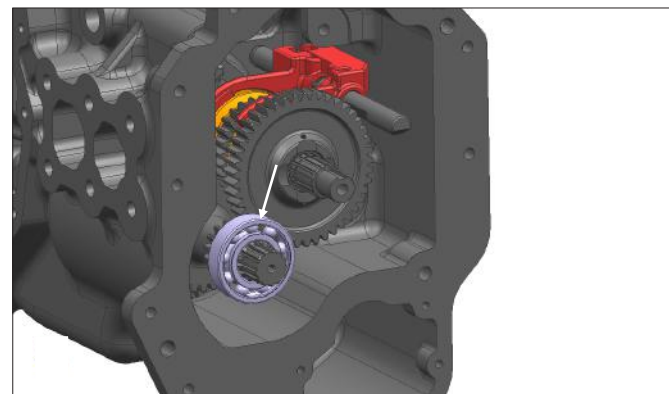

22. Assemble ball bearing 6206 in range lay shaft.

H.5 Assembly of Differential Housing

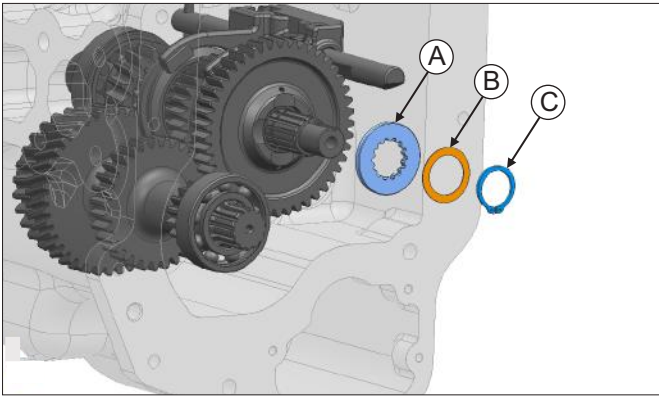

23. Insert the thrust washer (A), shim (B) and lock the circlip (C).

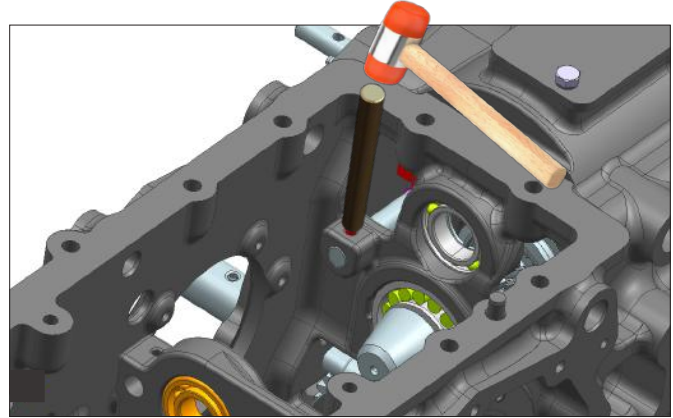

24. Engage the cotter sleeve with range shifter rod.

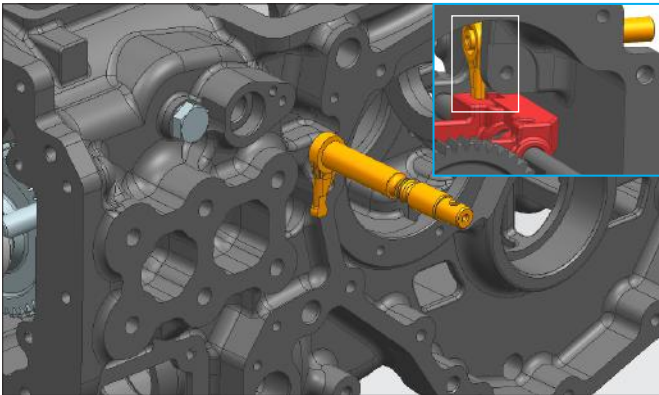

25. Insert the range pivot lug.

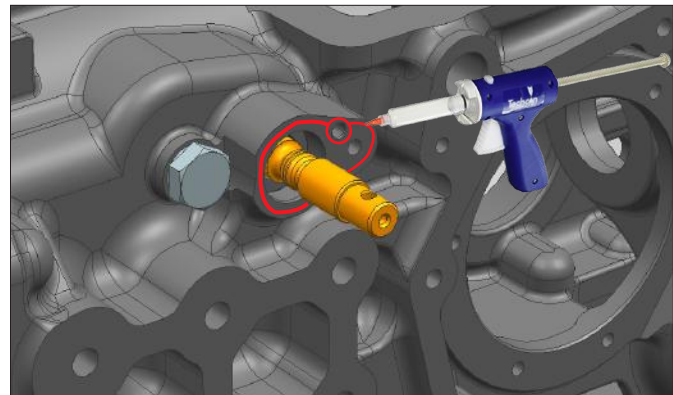

26. Apply sealant 5188 on the mounting hub area.

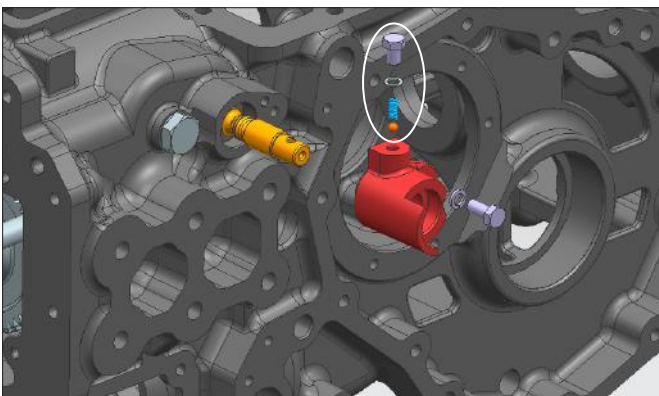

27. Insert spring, ball and tight the bolt as shown in figure. Assemble the range mounting hub. Tight bolt of range mounting hub. Torque= 13.28-16.96 lbf.ft (18-23 Nm)

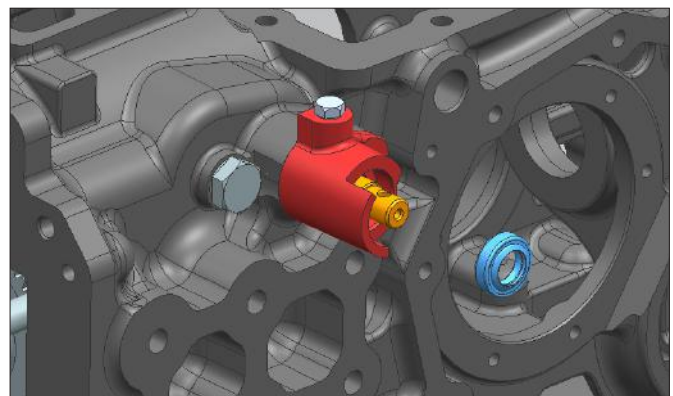

28. Seal fitted on the mounting hub.

H.5 Assembly of Differential Housing

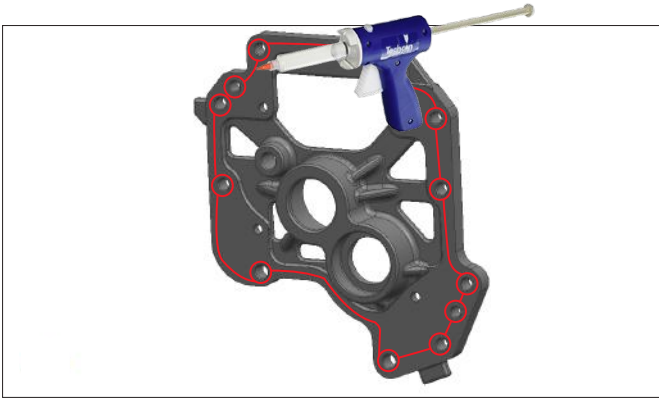

29. Apply sealant 5188 on the intermediate plate.

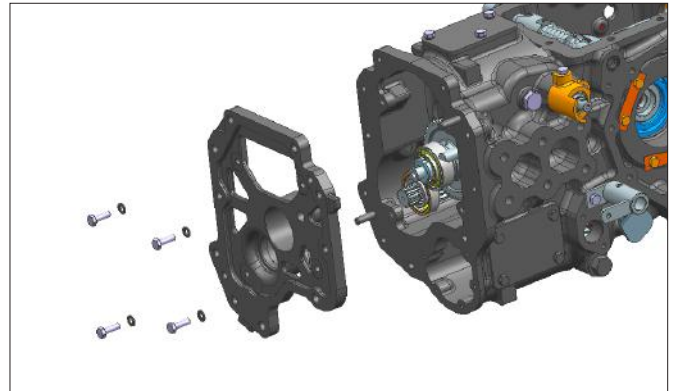

30. Assemble the intermediate plate.

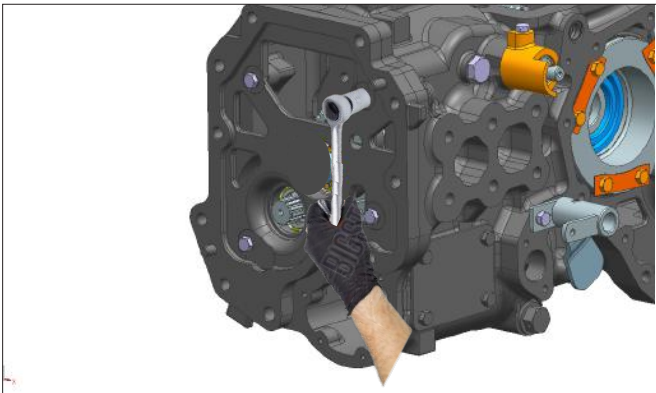

31. Tight the Bolts of intermediate plate.

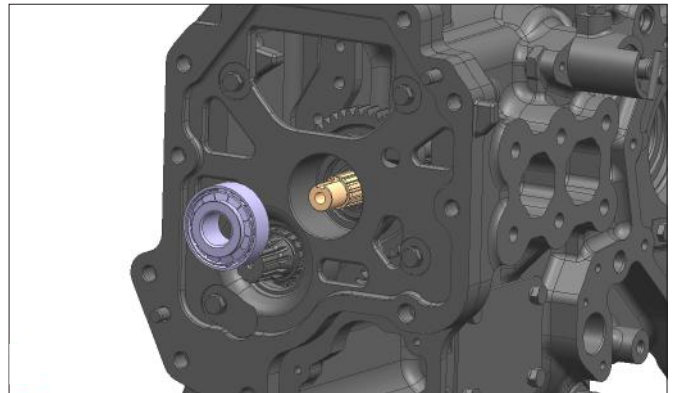

32. Assemble the taper roller bearing.

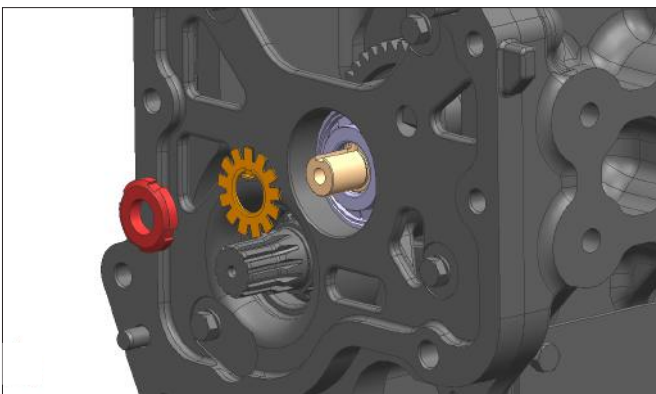

33. Insert the locking washer. Screw the withdrawal nut as per recommended pre-load between 6-9 kg by using tool 18ME235. Lock the withdrawal nut with locking washer.

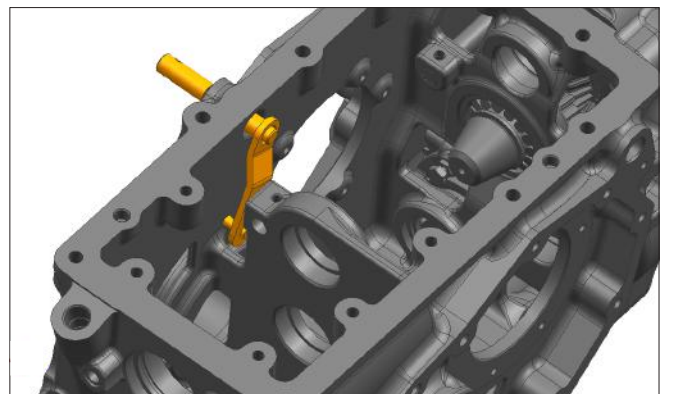

34. Assemble PTO pivot lug.

H.5 Assembly of Differential Housing

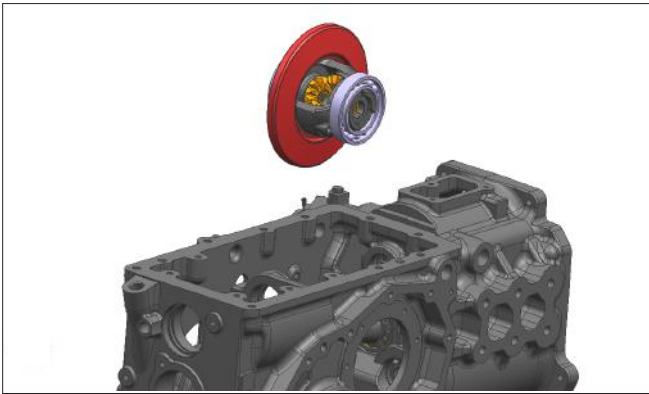

35. Assemble the cage sub assembly.

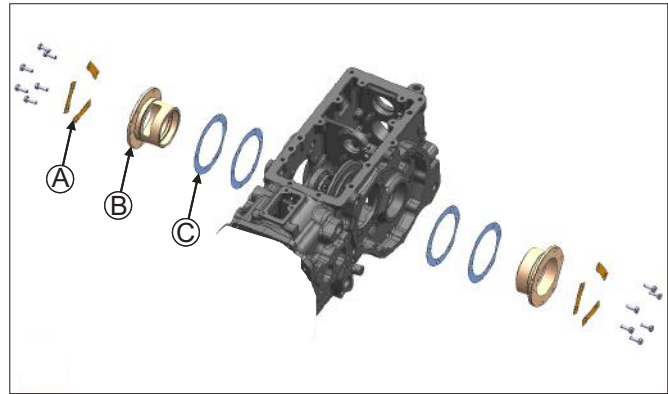

36. Insert the cage (B), locking washer (A) and shim (C) as per requirement. Apply loctite and tight the bolts.

Shim thickness size : 0.1, 0.2 and 0.5 mm.

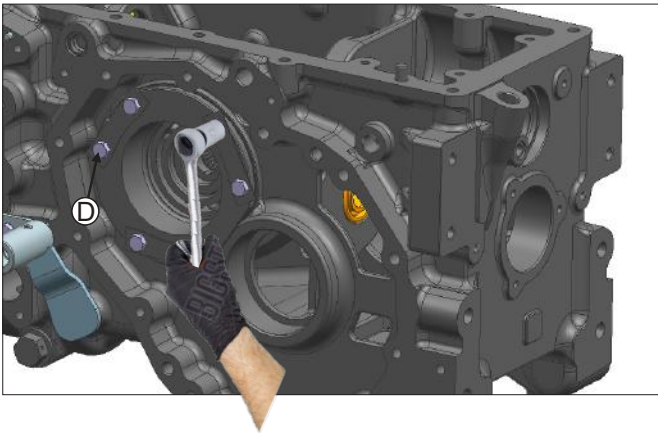

37. Tight the bolts (D) of cage and lock the bolts with locking strips.

Torque= 13.28-16.96 lbf.ft (18-23 Nm)

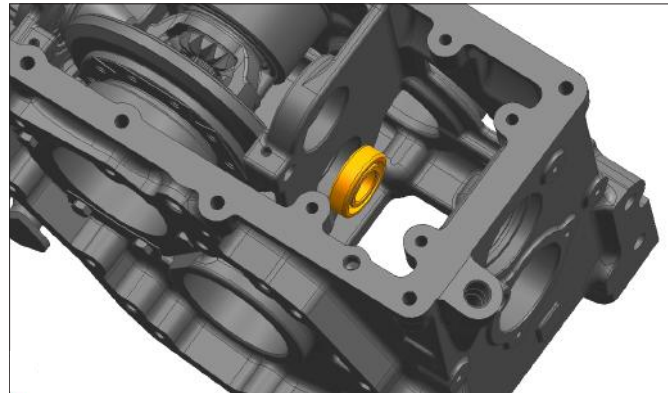

38. Assemble ball bearing 6205 in transmission housing by using mandrel 18ME244.

I.5 Differential Backlash Adjustment

1. While slowly rotating differential carrier, lightly tap carrier with a soft-faced mallet to make sure bearing on other side of ring gear is seated.
2. Attach a dial indicator to housing, as shown, with contact point positioned on ring gear splines.

NOTE: Ring gear carrier is not preloaded and will have normal side-to-side movement.

3. While holding input shaft, move carrier and ring gear to determine differential backlash. Backlash should be within specification.

Specification

Differential Backlash—Distance0.18—0.33 mm

4. To adjust backlash, remove six cap screws (C) Turn differential quill (A) to specified angle and install cap screws in the two threaded holes. Use cap screws to draw out the quill.

Specification

Differential Quill—Angle30°

5. Remove shims (B) to decrease backlash and add shims to increase.
6. Recheck backlash after removing or adding shims.
7. Tighten differential cap screws to specification.

Specification

Differential Cap Screw—Torque.....52 N•m (43 lb-ft)

- A—Differential Quill
- B—Shim
- C—Cap Screw (6 used)

IMPORTANT: Always check and adjust backlash after cone point adjustment has been made.

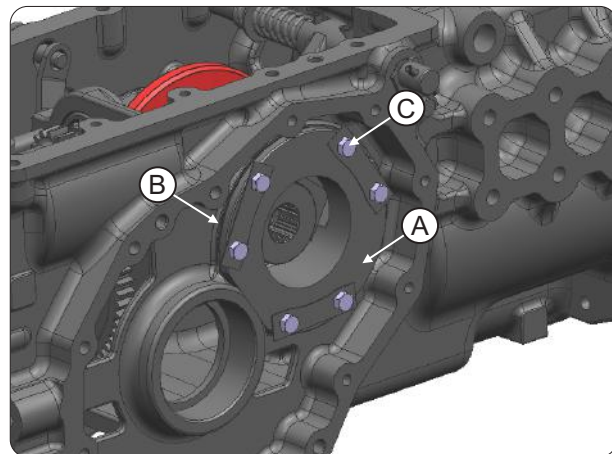
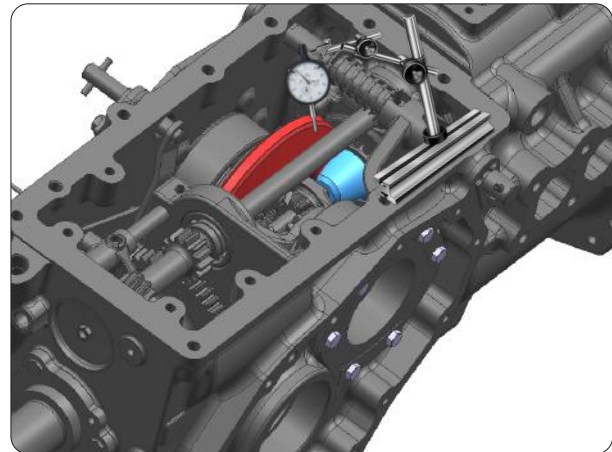
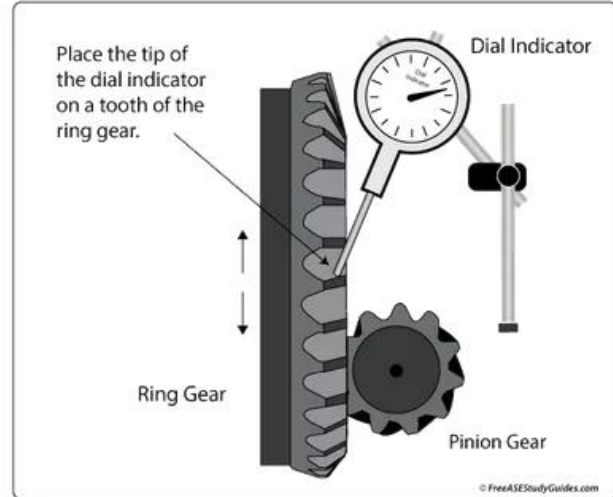

H.5 Assembly of Differential Housing

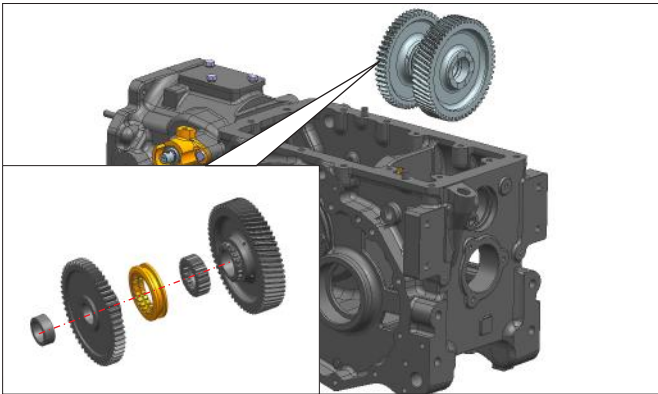

39. Assemble the PTO gears assembly.

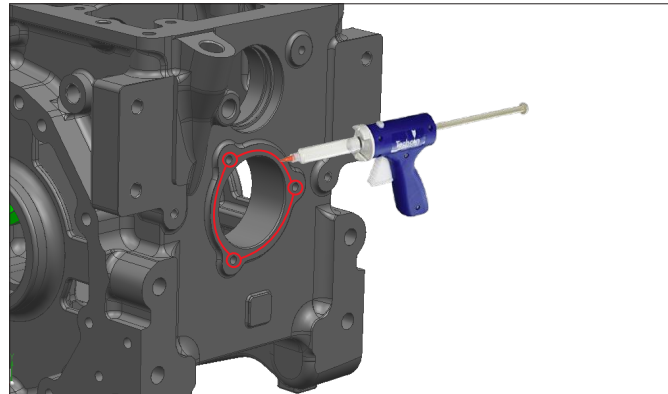

40. Apply sealant 5188 on transmission housing.

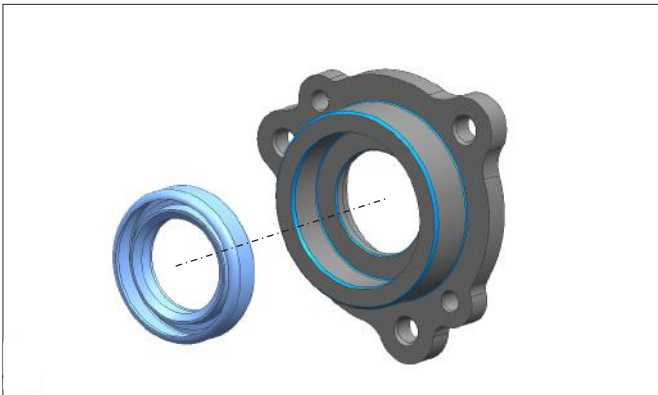

41. Assemble oil seal in cover PTO output shaft by using mandrel 18ME244.

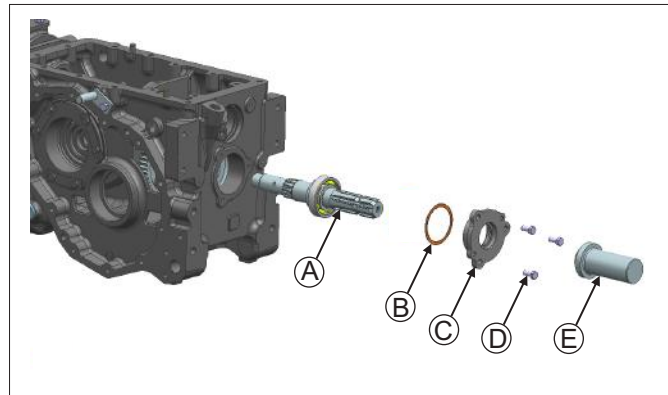

42. Assemble the PTO shaft rear with press fitted ball bearing 6207 (A). Maintain distance between bearing and housing face 17.85~17.9 and insert the shim (B). Assemble oil seal with cover (C).

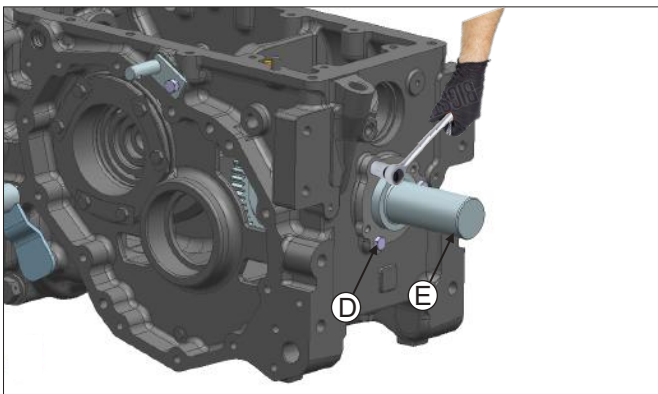

43. Tight the bolts (D) of cover PTO output shaft. Assemble the PTO cap (E).
Torque= 13.28-16.96 lbf.ft (18-23 Nm)

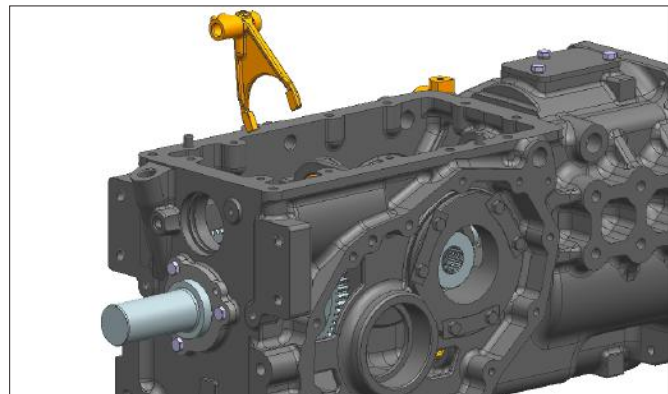

44. Insert the fork PTO.

H.5 Assembly of Differential Housing

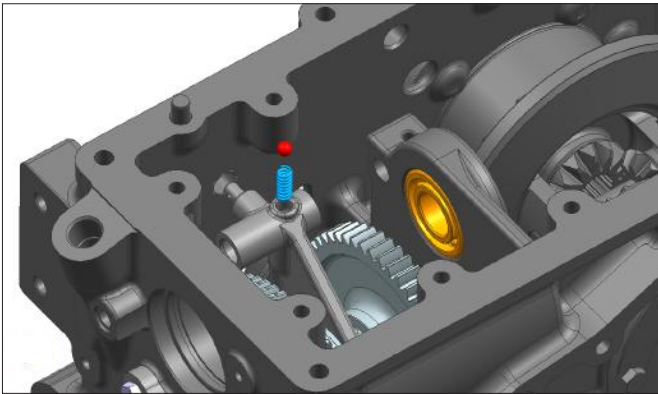

45. Insert the ball and spring in fork PTO.

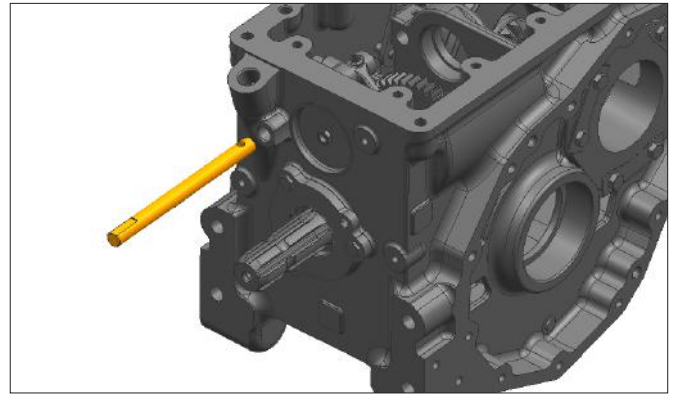

46. Assemble shifter rod PTO in fork and transmission housing.

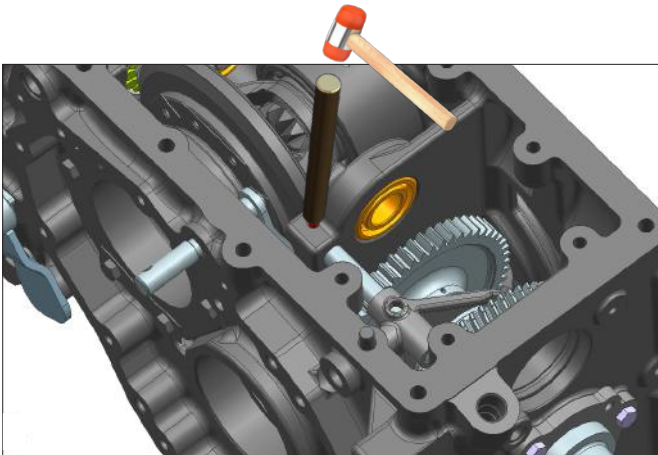

47. Engage the cotter sleeve of PTO shifter rod.

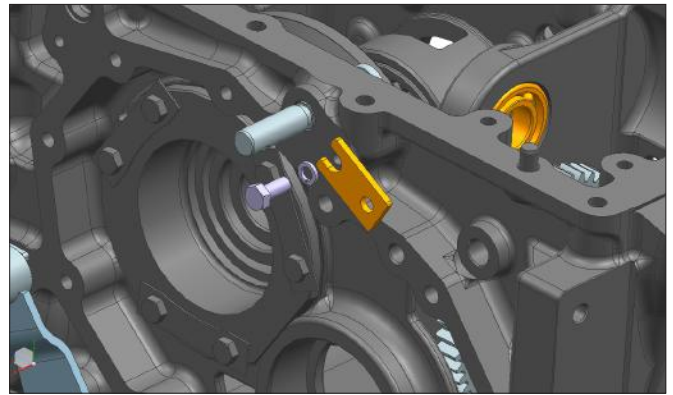

48. Insert the locking strip and tighten the bolt of PTO pivot lug.

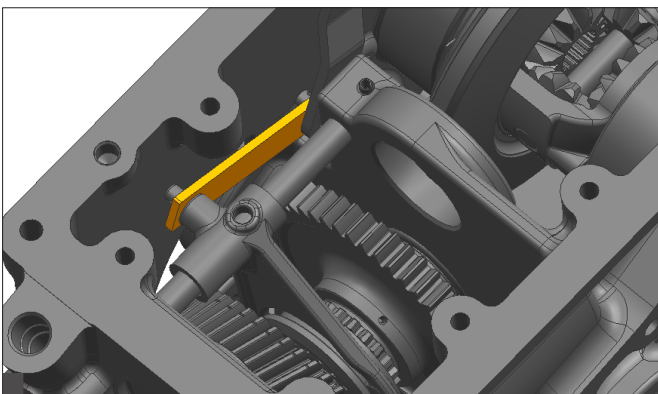

49. Insert the locking strip and tighten the bolt of PTO pivot lug.

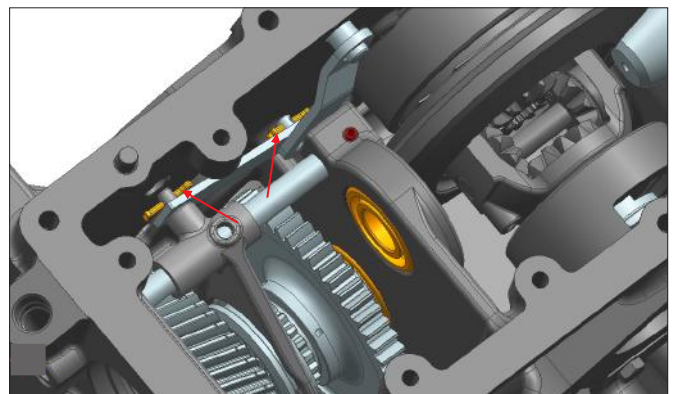

50. Insert the cotter pins and lock the PTO link shifter.

H.5 Assembly of Differential Housing



51. Assemble ball bearing 6205 in transmission housing by using mandrel 18ME244.

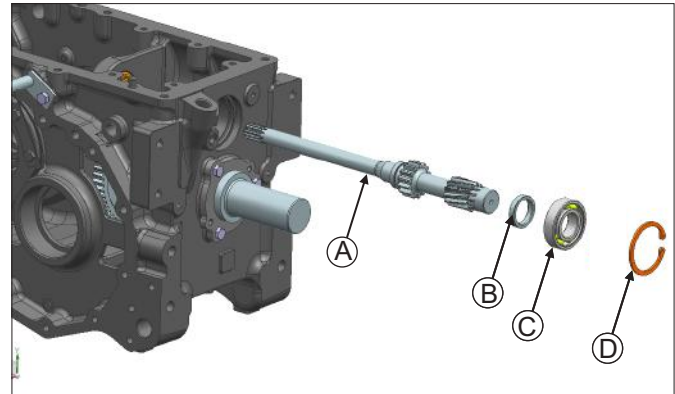

52. Insert the PTO intermediate shaft (A), spacer (B), ball bearing 6206 (C).

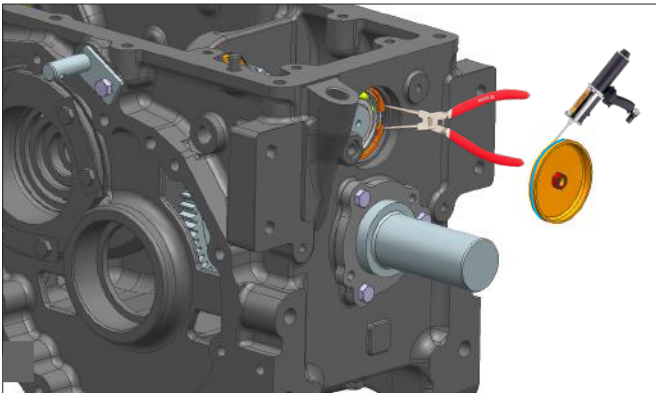

53. Lock the circlip (C). Apply loctite 243 and assemble the cover.

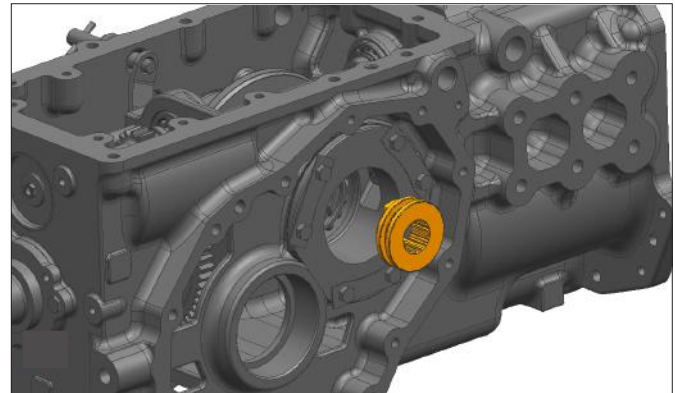

54. Assemble the sleeve differential lock.

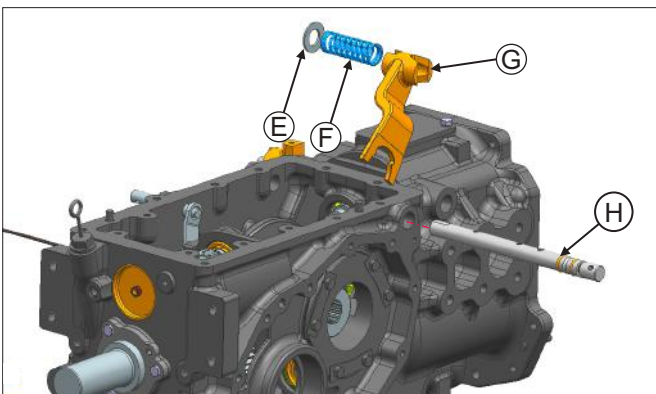

55. Assemble O-ring (H) in diff lock rod and Insert the fork (G), spring (F) and spacer (E) and assemble diff lock rod.

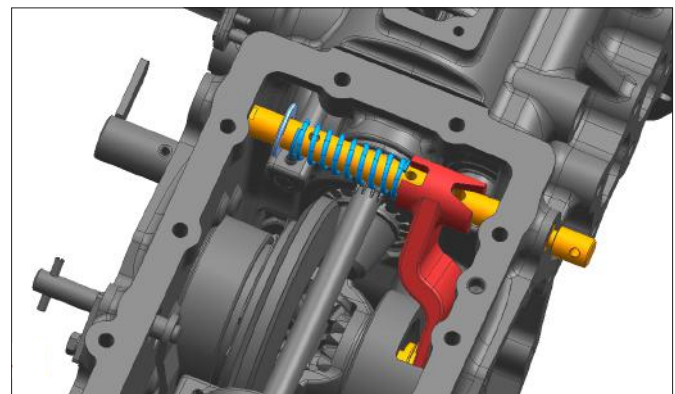

56. Assemble the rod diff lock, fork, diff lock, spring and spacer as shown in figure.

H.5 Assembly of Differential Housing

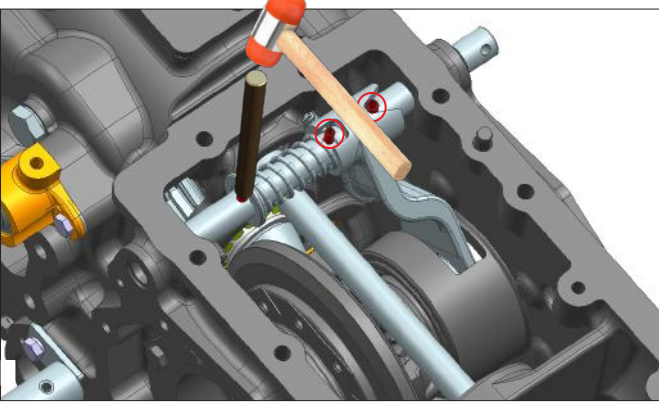

57. Engage the cotter sleeve of diff. lock rod.

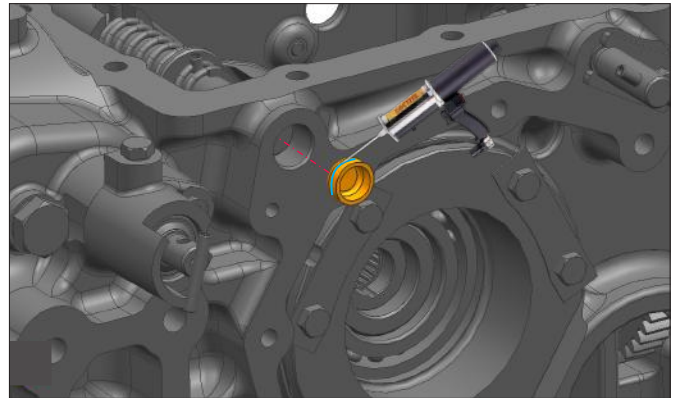

58. Apply loctite on the cap and fitted on the transmission housing by using mandrel.

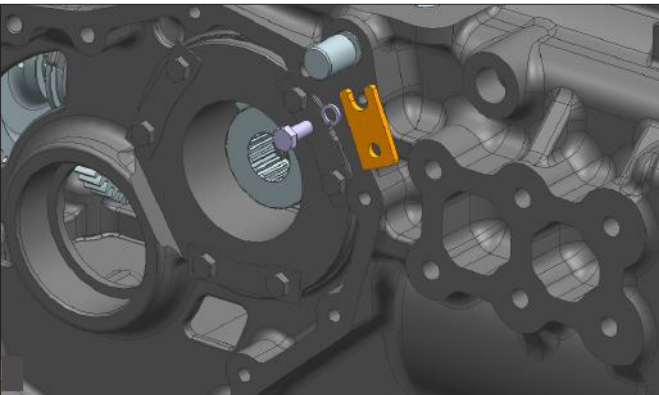

59. Assemble the locking. Tight the bolt.
Loctite 243 , Torque= 13.28-16.96 lbf.ft (18-23 Nm)

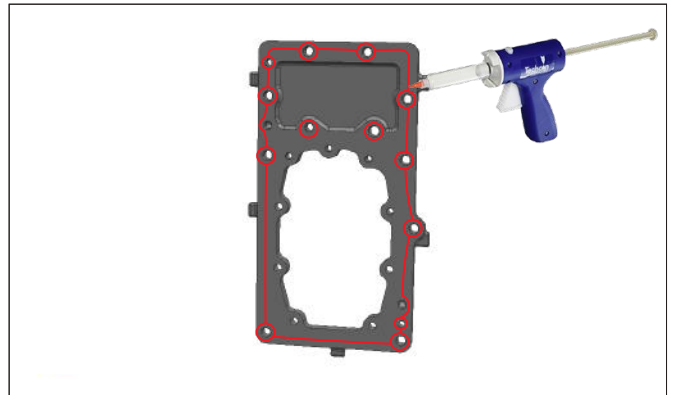

60. Apply sealant 5188 on the intermediate plate for lift housing.

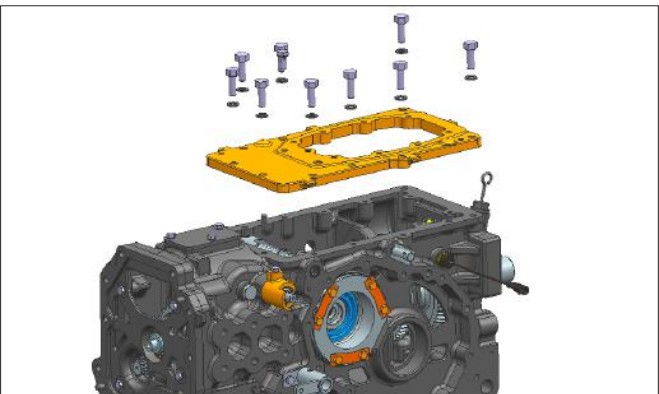

61. Assemble the intermediate plate.



62. Tight the bolts of intermediate plate for lift housing.

H.5 Assembly of Differential Housing

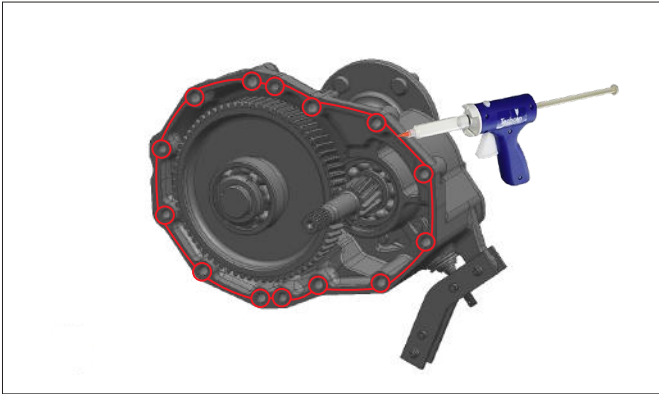

63. Apply sealant 5188 on the rear axle carrier housing.

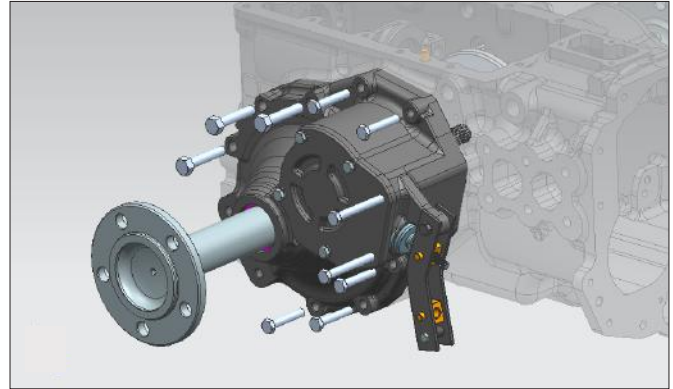

64. Apply Loctite 243 on bolt and tight the bolts of rear axle sub assembly.

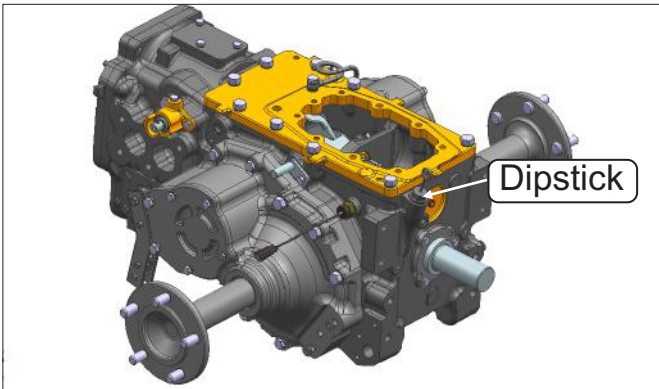

65. Assemble the dipstick assembly.

J.5 Troubleshooting

Gear Box :

S.NO.	PROBLEM	PROBABLE CAUSES	REMEDIES
1	NOISE		
	Humming (a peculiar noise)	Wear on gear teeth flank	Replace the gear.
		Damage on gear teeth flank	Replace the gear.
	Metallic grinding	oil level low.	Top up oil level.
	Whine (Bullet passing sound)	Backlash less	Correct the back lash either by replacing gear on housing.
		Gear machining improper	Replace the gear.
	Hissing (Leaking noise tent-tire to air lack)	worn out bearing	Replace the bearing.
		Bearing ball/race pitted	Replace the bearing.
	Rattling (Ruppict series of short loud noise)	Backlash more	Correct the back lash either by replacing gears or housing.
		Bearing seat loosen	Replace the gearing or replace the housing.
		Bearing play more	Replace the gearing.
		Excessive end play	Correct the end play by tightening the hex retaining nut or replacing spacers/gears.
	Knocking (Noise of sharp blue)	Dent on the gear tooth	Remove the dent by polishing.
		Gear tooth damage	Replace the gear.
Foreign matter present		Clean the gear train and strain the oil.	
2	HARD SHIFTING	Insufficient oil.	Top up the oil.
		Detent lock assy. Tight	Replace detent-retaining spring.
		Bent in shifter rod	Replace the shifter rod.
		Gear tooth battered	Replace the gear.
		Sliding Gears tight on shaft	Free the gear shaft by polishing or by replacing gear/shaft.
		Pilot bearing jam	Replacing the bearing
		Excessive clutch free paly	Adjust & correct free play.
		Inter-lock pin tight	Loosen the pin by polishing.
		Clutch is not disengaging.	Adjust & correct
3	GEAR SLIPPING OUT	Incomplete gear engaging	Engage gear fully.
		weak detent retaining spring	Replace the spring.
		Shifter rod retaining groove worn out	Replace the spring rod.
		Gear teeth rounded off	Replace the gear.
		Worn out / bent shifter fork	Replace the shifter fork.
4	GEAR STICKING	Detent balls/spring stuck	Free & lubrication.
		Scoring on fork.	Replace fork.
		Clutch not disengaging.	Adjust & correct.

J.5 Troubleshooting

Differential :

S.NO.	TROUBLE	PROBABLE CAUSE	REMEDIES
1	Humming	1.Incorrect adjustment of crown wheel & Tail pinion. 2.Tooth contact pattern not correct.	1.Re-adjust as per procedure. 2.Correct the tooth contact pattern by doing the adjustment as per the procedure.
2	Noise while Accelerating	Tooth contact shifted toward thick end.	Adjust tooth contact pattern as per the procedure.
3	Noise while De-accelerating	Tooth contact shifted toward thick end.	Adjust tooth contact pattern as per the procedure
4	Noise while Turning	1.Bevel pinion tight on bevel gear.	1.Correct the gap.
		2.Damaged teeth of bevel	2.Replace the damaged gear.
		3.Excessive backlash between bevel pinion and bevel gear	3.Correct the backlash.
		4.Defective axle bearing	4.Replace the bearing.

Brake :

S. No.	PROBLEM	PROBABLE CAUSES	REMEDIES
1.	NO BRAKING ACTION	Pedal linkage broken or disconnected	Replace or repair
2.	POOR BRAKING ACTION	Brake setting improper	Adjust & correct
		Glazed brake liners	Replace
3.	BRAKE STUCKING	Glazed brake disc	Correct by machining or replace
		Linkage retracting spring loose	Replace springs
		Brake disc plate spring tension less	Replace springs
4.	NOISE WHILE BRAKING	Binding in linkage	Lubricant & free
		Loose rivets of brake lining	Correct or replace
		Worn out brake lining	Replace
		Rough or worn out brake disc plate	Correct by machining or replace
		Foreign matter imbedded in lining	Clean the liners
		Loose part in the system.	Tighten the loose part

SERVICE MANUAL

S24 (9+9) SHUTTLE XL
Transmission