

SERVICE MANUAL

H24 HYDROSTAT CABIN

Transmission

SERVICE MANUAL

. HST TRANSMISSION

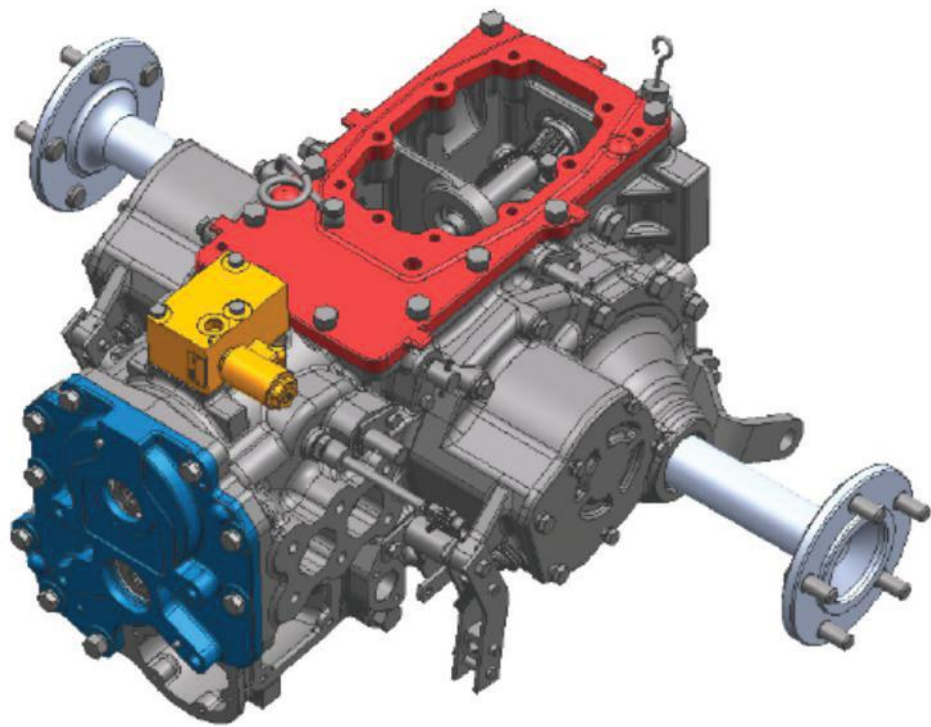

INTERNATIONAL TRACTORS USA CORPORATION

2332 MT. ZION ROAD

GREENWOOD, AR

PREFACE

Dear Customer,

We welcome you with great pleasure for joining **International Tractors Limited** family and thanks for faith and trust you have placed in the careful selection of your tractor.

We are sure that our dealer must have taken good care while delivering tractor upto your satisfaction.

Before using tractor, we highly recommended that you and any other person that will use your tractor read this operator's manual thoroughly.

Scheduled maintenance and operations can be easily performed with the use of this manual. To get best and trouble free performance from your tractor, please ensure for periodic maintenance as per recommended schedule in the owner's manual at authorized dealership.

Use only genuine **International Tractors Limited** spare parts from dealer/stockist for reliable and durable performance.

Information provided in this operator manual is accurate at the time of printing. Improvements and modifications are a continuous process at **International Tractors Limited** , therefore we reserves the right for modification at any time without prior notice.

For any support/query, feel free to call our dealership with the tractor details like Engine number and Chassis number.

We wish you prosperity and growth.

International Business

International Tractors Limited

Vil.-Chaik Gujran,P.O. Piplanwala 146022
Jalandhar Road, Hoshiapur, Punjab, India.

This publication has been written in compliance with International Standard ISO 3600 'Guide for information'. Contents and presentation of operation and maintenance manuals supplied with tractors and machinery for agricultural and forestry use.

TABLE OF CONTENTS

| | |
|---------------------------------------------------------|-------|
| 1 Warning Signs | 1-6 |
| Safety: Danger, Warning and Caution | 1-6 |
| 2 Safety Precautions | 2-7 |
| Notes in handling | 2-7 |
| Notes on mounting and removing | 2-7 |
| Notes on product operating | 2-7 |
| Notes on maintenance and storage | 2-8 |
| 3 Functions and Operation..... | 3-9 |
| Pump and Motor | 3-9 |
| Charge circuit | 3-9 |
| HST operating..... | 3-9 |
| 4 Precautions for Handling..... | 4-10 |
| Storage | 4-10 |
| Contamination control..... | 4-10 |
| Method of coupling shafts | 4-10 |
| Method of coupling trunnion | 4-10 |
| Hydraulic fluid | 4-10 |
| HST Hydraulic Circuit Diagram..... | 4-14 |
| Starting up..... | 4-15 |
| Hydraulic Filter Bleeding Procedure..... | 4-15 |
| Oil temperature control | 4-16 |
| Piping..... | 4-16 |
| 5 Timing of Check and Replacement | 5-17 |
| Timing of Check and Replacement of Hydraulic Fluid..... | 5-17 |
| 6 Main Dimension | 6-18 |
| Main Dimension | 6-18 |
| 7 Transmission Oil Filler Plug/Dipstick | 7-19 |
| Transmission Oil Filler Plug/Dipstick | 7-19 |
| 8 HST Power Flow Chart | 8-20 |
| HST Power Flow Chart | 8-20 |
| 9 Filling and Checks..... | 9-22 |
| Draining and Checks | 9-22 |
| 10 Service Schedule | 10-23 |
| Service Schedule | 10-23 |
| 11 Special Service Tool | 11-24 |
| Special Service Tool | 11-24 |
| 12 Disassembly of Pump | 12-26 |
| Disassembly of Pump..... | 12-26 |
| 13 Disassembly of Differential Housing..... | 13-32 |
| Dis-assembly of Differential Housing | 13-32 |
| Dis-assembly of Mid PTO sub assembly..... | 13-49 |
| 14 Disassembly of Trumpet Housing | 14-52 |

TABLE OF CONTENTS

| | |
|--------------------------------------------|--------|
| Disassembly of Trumpet Housing | 14-52 |
| 15 Disassembly of Tail Pinion Shaft | 15-54 |
| Disassembly of Tail Pinion Shaft | 15-54 |
| 16 Disassembly of Range Lay Shaft | 16-57 |
| Disassembly of Range Lay Shaft | 16-57 |
| 17 Disassembly of PTO Sub Assembly | 17-60 |
| Disassembly of PTO Sub Assembly | 17-60 |
| 18 Disassembly Differential Cage Sub | 18-61 |
| Dis-assembly Differential Cage Sub | 18-61 |
| 19 Assembly of Differential Cage Sub | 19-64 |
| Assembly of Differential Cage Sub | 19-64 |
| 20 Assembly Tail Pinion Shaft | 20-67 |
| Assembly of Tail Pinion Shaft | 20-67 |
| 21 Assembly of Range Lay Shaft | 21-70 |
| Assembly of Range Lay Shaft | 21-70 |
| 22 Assembly of PTO Sub | 22-73 |
| Assembly of PTO Sub | 22-73 |
| 23 Assembly of Trumpet Housing | 23-75 |
| Assembly of Trumpet Housing | 23-75 |
| 24 Assembly of Drop Box Mid PTO | 24-79 |
| Assembly of Drop Box Mid PTO | 24-79 |
| 25 Assembly of Differential Housing | 25-82 |
| Assembly of Differential Housing | 25-82 |
| 26 Assemble of Pump | 26-101 |
| Assemble of pump | 26-101 |
| 27 Differential Backlash Adjustment | 27-108 |
| Differential Backlash Adjustment | 27-108 |
| 28 Pressure measurement procedure | 28-109 |
| Pressure measurement procedure | 28-109 |
| 29 Troubleshooting | 29-112 |
| Troubleshooting | 29-112 |

1. WARNING SIGNS

Safety: Danger, Warning and Caution

Whenever you see the words and symbols shown below, used in this book and on decals, you **MUST** take note of their instructions as they relate to personal safety.



DANGER :The symbol and the word DANGER indicates an imminently hazardous situation, which, if not avoided, will result in DEATH OR VERY SERIOUS INJURY.



WARNING

WARNING :The symbol and the word WARNING indicate a potentially hazardous situation. if the instructions or "procedures are not correctly followed it could result in DEATH OR SERIOUS INJURY.



CAUTION

CAUTION: The symbol and the word CAUTION indicate a "potentially hazardous situation, which, if not avoided, may result in MINOR INJURY.

IMPORTANT

The word **IMPORTANT** is used to identify special instructions or procedures which, if not strictly observed, could result in damage to, or destruction of the machine, process or its surroundings

NOTE

The word **NOTE** is used to indicate point of particular interest for more efficient and convenient repair or operation

2. SAFETY PRECAUTIONS

Notes in handling



For safe handling, please wear protective equipment suitable for your situation.



For safe handling, please pay attention to the working posture at handling HST.



Please do not apply external force to the product. External force may cause troubles such as faulty operation, breakage or oil leakage.



For safe handling, please wipe off the hydraulic oil on the HST and the floor before handling.

Notes on mounting and removing



Wrong processes in mounting and removing may cause you injury or accidents. Mounting, removing, plumbing, wiring, etc. must be done with correct knowledge.



Before working.

1. Turn the power of equipment off certainly.
2. Make sure the electric motor or the engine is stopped.
3. Check the pressure in hydraulic piping is at atmospheric pressure.



Please make mounting holes and fitting plane clean before mounting the product. Contaminants and incorrect tightening will cause breakage and oil leakage of the product.



For safety working and to avoid damaging to product and machine, please mount the product with the predetermined bolts at correct tightening torque.

Notes on product operating



DANGER!!

Do not use the product in a dangerous situation such as explosion or burning.



Be sure to attach a protective cover to the rotating shaft to prevent hands and clothing from getting caught.

2. SAFETY PRECAUTIONS



When unusual behavior (e.g. abnormal noise, oil leakage, smoke, etc.) happened, please stop the machine immediately, and take the appropriate measures.

Using products without taking appropriate measures may cause many risks of breakage of products, fire, injury, etc.



Notes for the initial starting-up of machine.

- Confirm all of the components in the hydraulic circuit are good condition and in place.
- Confirm all of connections are certainly connected.

After checking completely, start the machine.



Only use the product within the performance range provided in the technical data.



To avoid getting burn injury, do not touch the product during or soon after the operation. This product will become very hot for increase in oil temperature during operation.



Inadequate hydraulic fluid may cause faulty operation, breakage, etc.

Please use adequate hydraulic fluid and maintain the cleanness at recommended value.

Notes on maintenance and storage



Never modify the product by customers.



Do not disassemble or reassemble the product without ITL's permission.

Incorrect disassembling or reassembling will cause performance degradation, and it may cause failures or accidents.



When transporting and storing the product, please pay attention to environmental conditions such as ambient temperature and humidity, and keep dust proof and rust prevention.



When using the product after long-term storage, it may be necessary to replace the seal.

3. FUNCTIONS AND OPERATION

Pump and Motor

The rotary component is built with an input shaft, a cylinder block in which nine pieces of pistons are assembled and a valve plate. A shaft is connected with a driving source. (In general, it is an engine or an electric motor.) When the shaft is rotated, the cylinder block is also rotated synchronously.

Charge circuit

In principle, internal leakage exists in the HST circuit. In order to compensate for the internal leakage, the charge circuit is required in the hydraulic circuit.

The charge pump supplies the hydraulic fluid into the HST circuit through the check valve. Excess hydraulic fluid flows through the charge relief valve into the HST case, cools the pump and the motor, and returns to the oil tank.

HST operating

When the trunnion lever is neutral, even if the input shaft is rotated, the variable pump in HST does not discharge and suction any hydraulic fluid. Therefore, hydraulic fluid from the pump is not supplied to the motor and the output shaft does not rotate.

Two oil paths connecting the pump and the motor are linked to the charge circuit. The charge pump supplies the hydraulic fluid to the HST circuit through the check valve. Excess hydraulic fluid from charge pump flows through the charge relief valve into the HST case, cools the pump and motor and returns to the oil tank.

When the trunnion lever is tilted from the neutral position to the α side while rotating the input shaft in the clockwise and when the lever is at a slight tilt angle, There is no volume difference in the cylinder due to the taper angle of the movable thrust plate. Because of above reason, the output shaft does not rotate. If the lever is tilted beyond the taper angle of the movable thrust plate, the hydraulic fluid is supplied to the motor by pump operation and the output shaft rotates. If the input shaft rotates to the right, the output shaft will rotate to the right. The rotate direction of each shaft is defined as the direction from viewing the end surface of each shaft. When an excessive load is applied to the output shaft and the HST pressure rises to 34.3 MPa or more, the relief valve operates. (The relief valve is normally closed.) Each of components is protected by activation of the relief valve from damage, but all the energy is converted to heat during relief operation, so the oil temperature in the HST circuit suddenly rises.

Therefore, please make the operation time of the relief valve as short as possible (within 30 seconds). Hydraulic fluid that has passed through the relief valve flows into the low pressure side oil passage. The operating principle is the same as on the α side. When the trunnion lever is tilted from the neutral position to the β side and it is at slight angle, the output shaft does not rotate by the movable thrust plate function. If it is tilted more than that angle, the output shaft will rotate to the left.

4. PRECAUTIONS FOR HANDLING

Storage



If HST will not be in operation more than 1 month, for the rust prevention, **fill the HST case with clean hydraulic fluid and store it in a clean and dry place.**

Contamination control



For the purpose of product protection, HST is shipped in a state of being sufficiently cleaned. Please be careful not to mix the contaminant contained in outside when using HST or adding the hydraulic fluid to the oil tank.

Moreover, please manage the contamination level of the hydraulic fluid to be within NAS9 class. Large particle (especially more than 100 μ m) causes fatal damage to HST in a short time.

Method of coupling shafts



Assemble working should be done carefully so as to align the center of the HST's input shaft and the engine's output shaft. The amount of centering misalignment between shafts must be within 0.05mm. (Please be carried out the same method also in HST's output shaft and PTO shaft.)

When mounting or dismounting HST, please be careful that the excess thrust load will not be applied to each shaft end.

Method of coupling trunnion



1. There is a risk of damage to the trunnion shaft of HST, if the torque beyond the operating torque of HST is applied to the trunnion shaft. Therefore, please make sure the stopper on the machine side works under the angle at which the maximum tilt angle stopper of HST acts.

2. Please consider so as not to wet the trunnion lever and the oil seal. The rust generated on a lever by water droplets could cause an oil leakage.

Hydraulic fluid



A hydraulic fluid is one of the important elements.

A hydraulic fluid transmits the hydraulic power and has the function to lubricate each hydraulic equipment parts.

Therefore, a selection and handling of the hydraulic fluid will significantly affect the product life and its performance.

In general, the hydraulic fluid is required following quality items, excellent oxidation resistance, rust prevention, the anti-emulsification, and lubrication. And it is also necessary that the characteristics of not damaging seals, etc.

ISO VG46 or VG56 (SAE 10W-30) equivalent hydraulic fluid are recommended for this HST.

However, please use hydraulic fluid in single grade and not mix different types.

4. PRECAUTIONS FOR HANDLING

Neutral

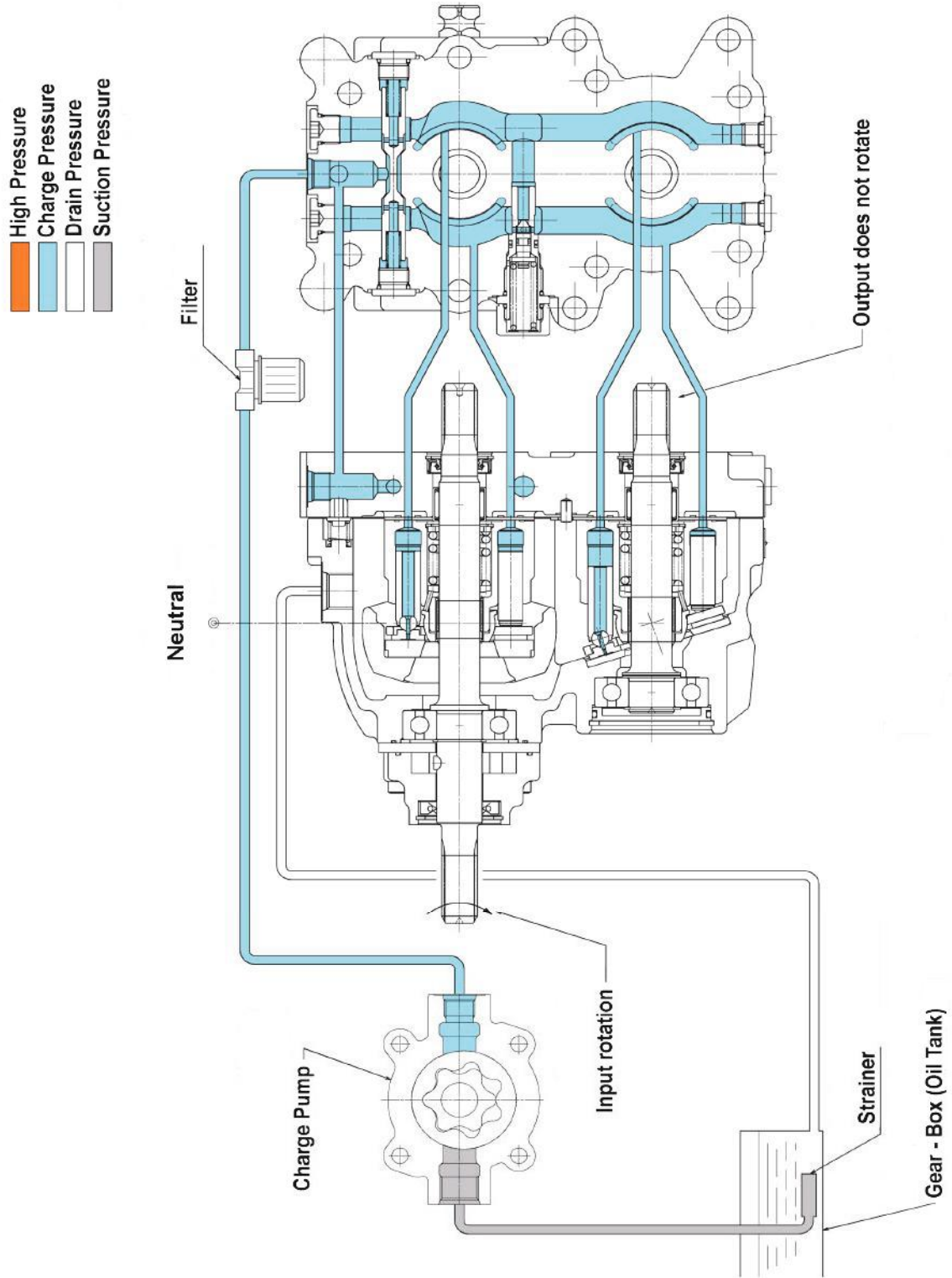

Fig. 1.1 Neutral

ITL000737

4. PRECAUTIONS FOR HANDLING

Forward

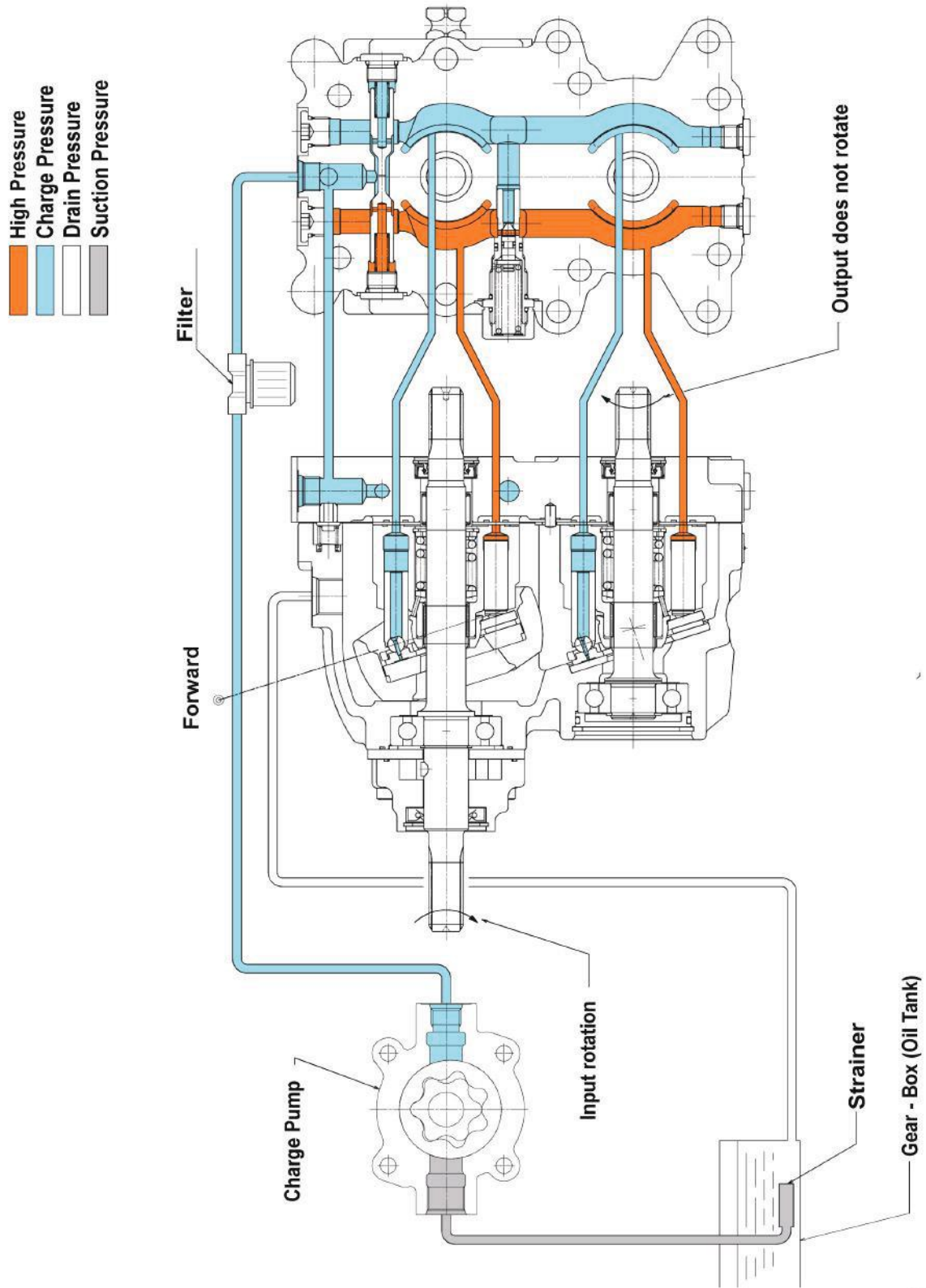

Fig. 1.2 Forward

ITL000738

4. PRECAUTIONS FOR HANDLING

Reverse

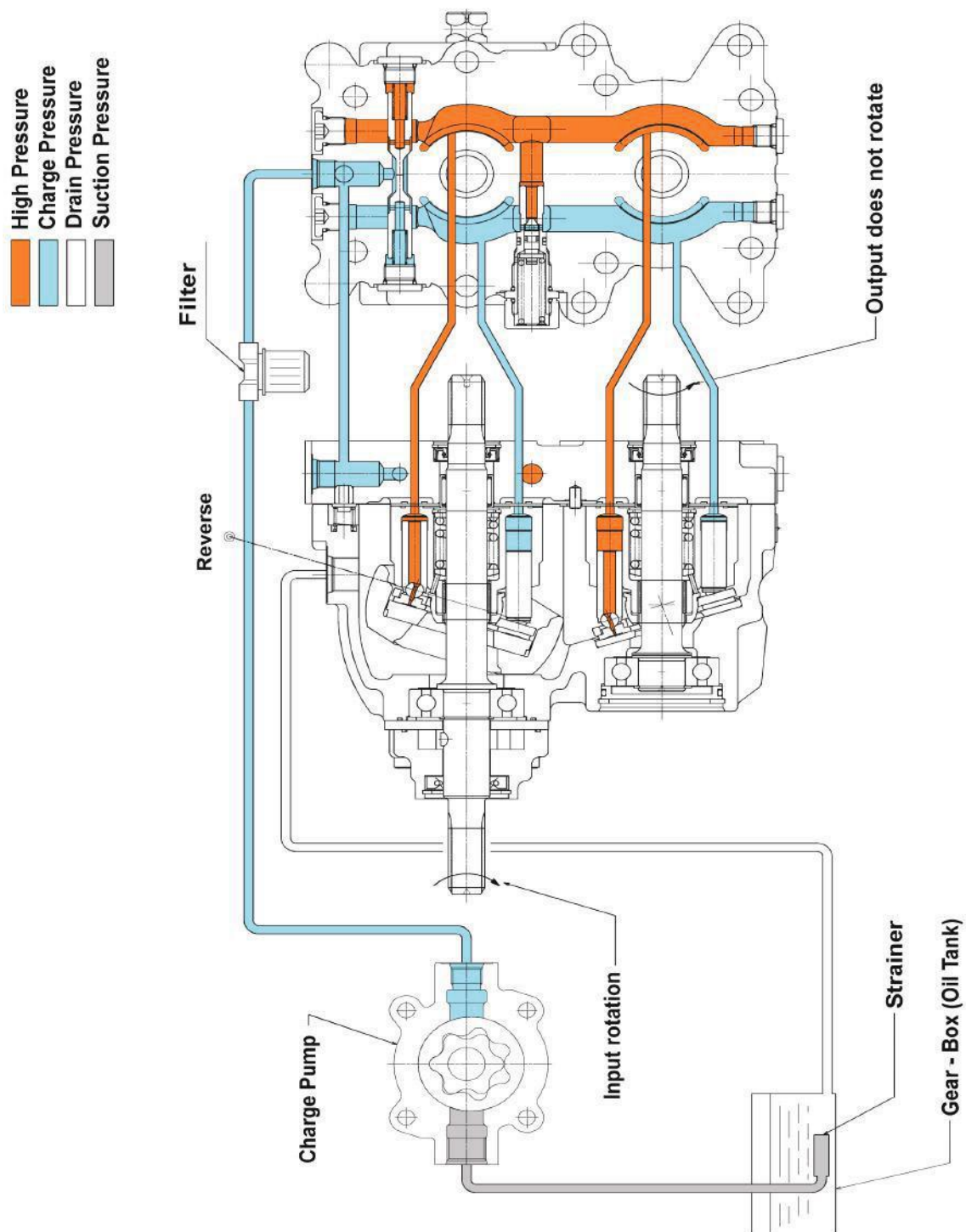
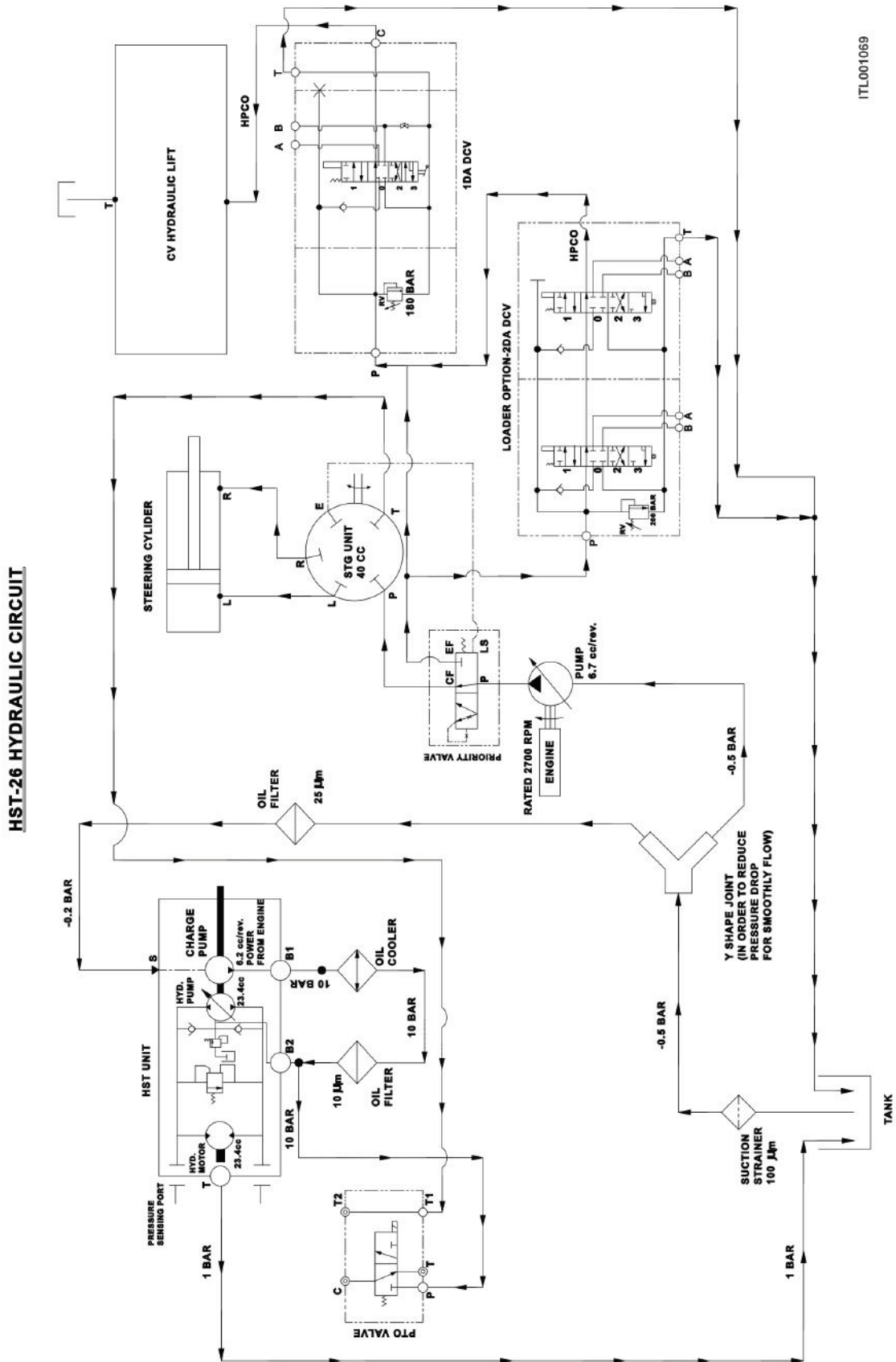

Fig. 1.3 Reverse

ITL000739

4. PRECAUTIONS FOR HANDLING

HST Hydraulic Circuit Diagram



ITL001069

4. PRECAUTIONS FOR HANDLING

Starting up

1. Fill the HST case with the hydraulic fluid.
2. Bleeding of HST is required.

How to bleed :- In idle state of the engine, please repeat operating the lever (or the pedal) slowly to move vehicle forward and backward.

3. The crackle noise by the aeration is generated from HST when the bleeding is not enough. Please continue the above mentioned operation until the crackle noise is not emitted.

4. The hydraulic circuit has the possibility of including some air at the time of HST installing. If a large amount of air is contained in the hydraulic circuit, the HST output shaft may fail to rotate. In this case, please tilt the trunnion lever to maximum angle with the state of the engine is idling. After a brief interval, the output shaft will start rotating. The vehicle will suddenly accelerate when bleeding is complete. For safe work, it is necessary that measures are carried out. (e.g. Lifting the vehicle)

5. After it was confirmed that there are no abnormal noise and vibration in the operation of low-engine-rotation, raise the engine speed to the specified value.

Hydraulic Filter Bleeding Procedure

Bleeding Procedure of the main hydraulic filter

1. Start the tractor at idle RPM.
2. Loosen the banjo bolt (1) from the hydraulic filter and bleed the system for 60 to 70 seconds by bleeding 400 to 500 ml oil.

Note: While bleeding, the tractor should be ON.

3. Tighten the banjo bolt (1) properly.
4. Turn off the Tractor.

Check the Transmission Oil level and it should be between minimum and maximum mark. Top-up recommended oil, if found below the minimum level.

Important: Use ONLY VG 32 grade transmission oil.

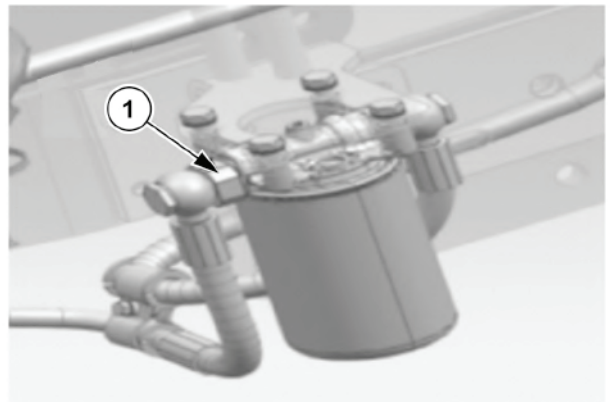

ITL001065

4. PRECAUTIONS FOR HANDLING

Oil temperature control

In the hydraulic equipment, it is very important to restrict the temperature range of the hydraulic fluid. High temperature increases promotes more degradation of antioxidant substance. Moreover, low temperature causes increasing viscosity of a hydraulic fluid, and decreasing mechanical efficiency. Therefore, please abide by the following cautions.

1. Starting temperature :- Please operate after the hydraulic fluid has been warmed more than 10°C by the warming-up operation or using oil heater.
2. Oil temperature of ordinary operating :- It is recommended that the temperature range of the hydraulic fluid in operation is 20°C – 60°C.
3. Upper limit of temperature of hydraulic fluid in operation. The upper limit of temperature of hydraulic fluid in operation is 90°C. Therefore, if using HST continually at oil temperatures above 90°C, the product lifetime of HST and hydraulic fluid will be shortened. This is decided based on an influence of the viscosity change, the stability against oxidation of hydraulic fluids, and the deterioration of oil seals and O-rings, etc.

Piping

1. Please select the inside diameter, length, bend, etc. to the drain piping of HST so that the HST case pressure is less than the value listed in the HST specifications.
2. Before piping, please remove the contaminants completely such as the scales from inside of pipes by acid pickling.
3. At the time of piping, please be careful not to get contaminants into the HST from each port. After the piping work has been completed, please fully flush the hydraulic circuit.

5. TIMING OF CHECK AND REPLACEMENT

Timing of Check and Replacement of Hydraulic Fluid

Even if the hydraulic fluid is clean at beginning, contaminants like sludge will be generated in the hydraulic circuit or the oil tank while continually using of HST over a long period of time. The contaminants in hydraulic fluid will damage the components of HST. Moreover, the deterioration of hydraulic fluid causes a loss of its own lubricating function.

It is ideal to determine the degradation status of hydraulic fluid by periodic inspection and replace (if needed), but practically it is considered that it is difficult to determine the condition of the hydraulic fluid in the working site. Therefore, as one of the rough indications, the method for determining the hydraulic fluid by appearance is described below.

| The judgment method by the appearance | | | |
|--------------------------------------------|-------|----------------------------|-----------------------------|
| External | Smell | State | Measures |
| Transparent (The color does not change.) | Good | Good | Replacement is unnecessary. |
| Transparent (There are small black spots.) | Good | Contamination of substance | Filtration is necessary. |
| Milky-white | Good | Water Contamination | Replacement is necessary. |
| Black | Stink | Oxidation degradation | Replacement is necessary. |

Period for replacement

Usually, the hydraulic fluid which has been used in the HST should be replaced with new one in the oil replacement maintenance for the first 50 hours of use. Afterwards, please replace the hydraulic fluid with new one either the shorter of annual or 250 hours of use.

Note :- Please replace the hydraulic fluid before the start of use of the year.

Precautions for oil replacement

Please be sure to replace the new hydraulic fluid after flushing HST.

It is not sufficient only to replace the used fluid to new one because the contaminants (deteriorated oil, precipitation of sludge, moisture, etc.) still remain also in the hydraulic circuit and oil tank at replacement. Those impurities may cause performance degradation and shortening of the product life.

6. MAIN DIMENSION

Main Dimension

Transmission

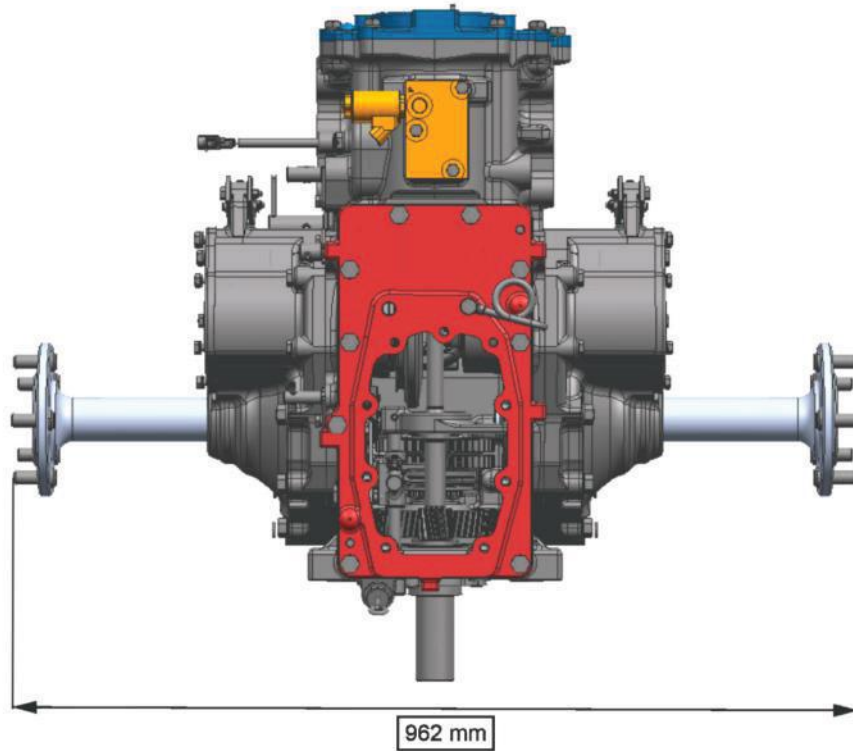

ITL000411

Transmission Oil Drain Plugs:-

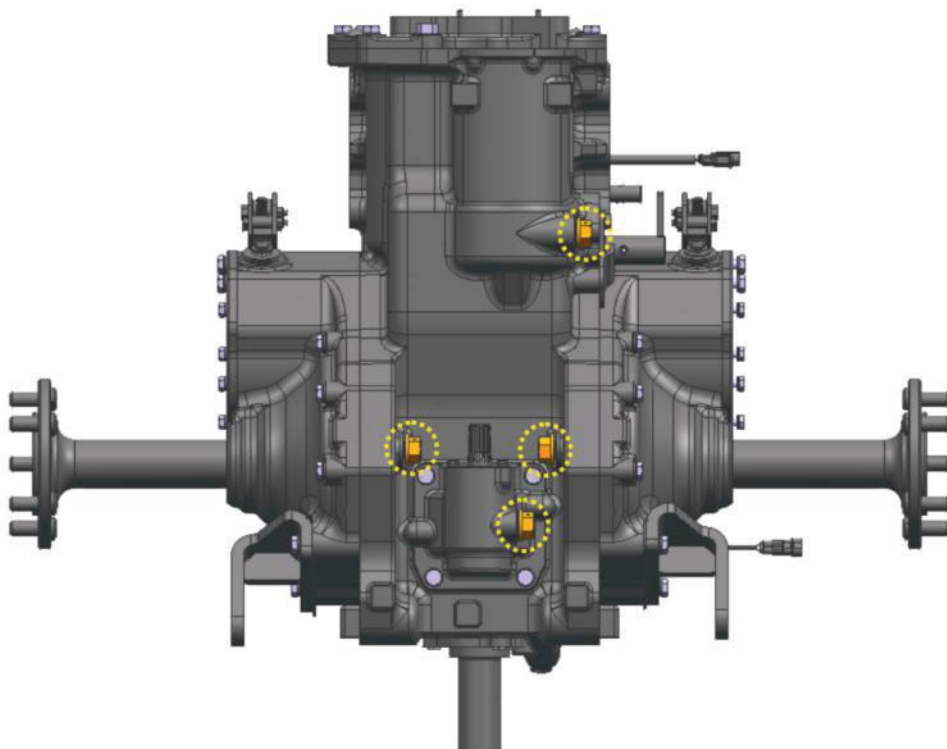

ITL000412

7. TRANSMISSION OIL FILLER PLUG/DIPSTICK

Transmission Oil Filler Plug/Dipstick

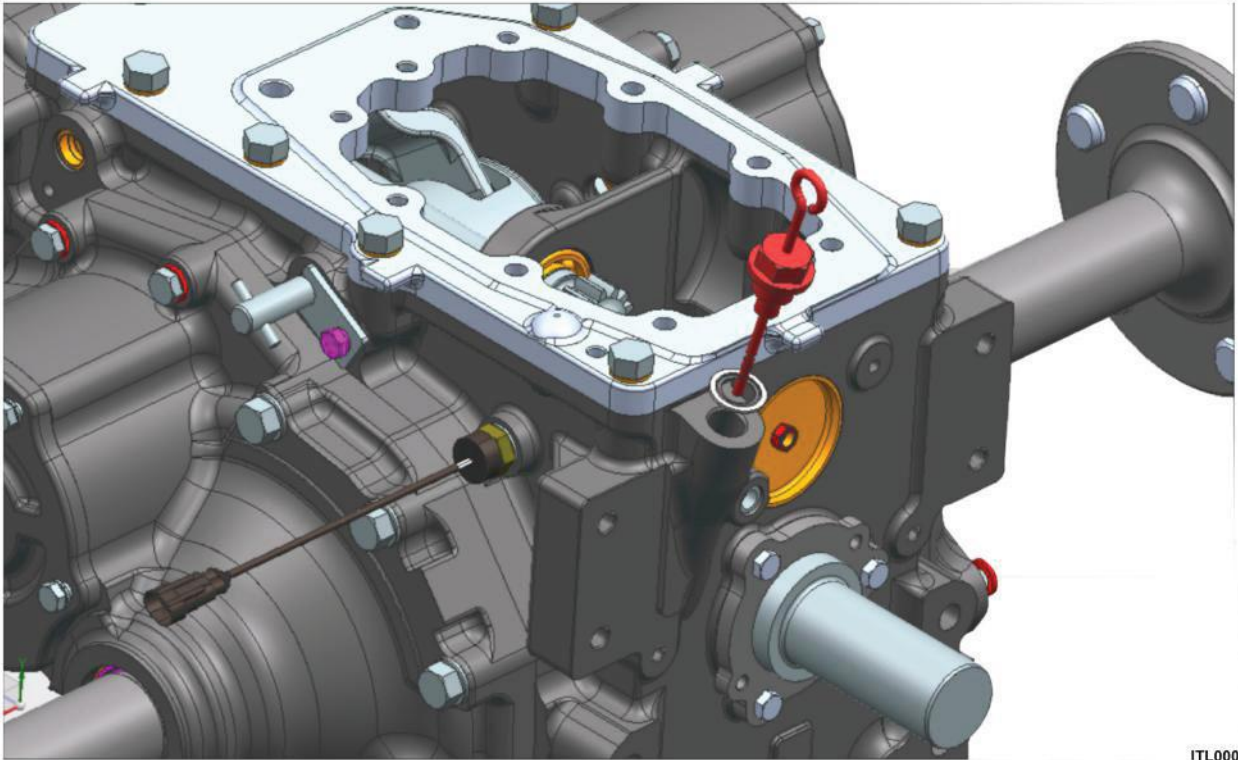

ITL000413

Transmission Oil

- Capacity : 25 Litres [6.6 US Gallons].
- Grade : ISO VG-32.

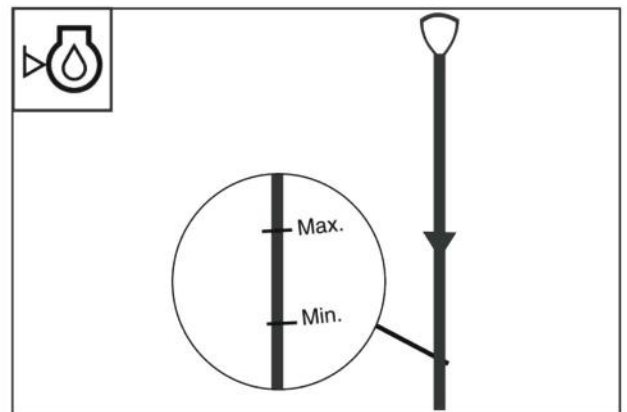

ITL000414

Sealant and Adhesives

| Gasket Sealant and Loctite | |
|----------------------------|---------------------------|
| Adhesive make and type | Technical characteristics |
| Sealant 5811 | Flat surface sealing |
| Loctite 243 | Bolt and Nut |
| Loctite 262 | Tail Pinion Nut |

8. HST POWER FLOW CHART

HST Power Flow Chart

1. High Power Flow

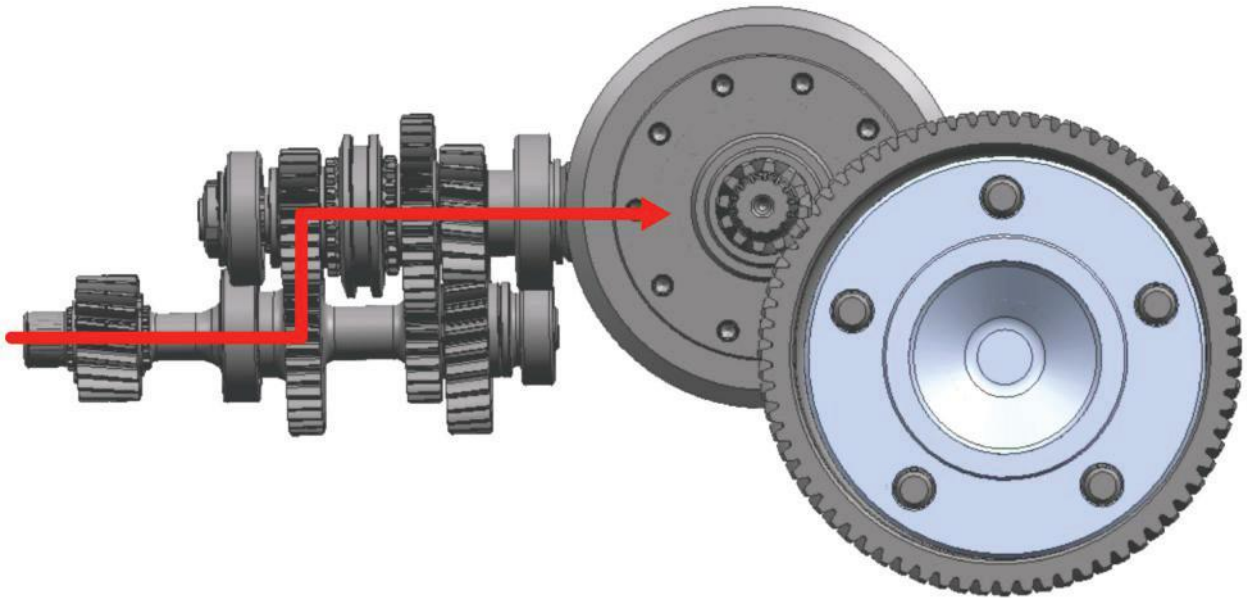

ITL000415

2. Low Power Flow

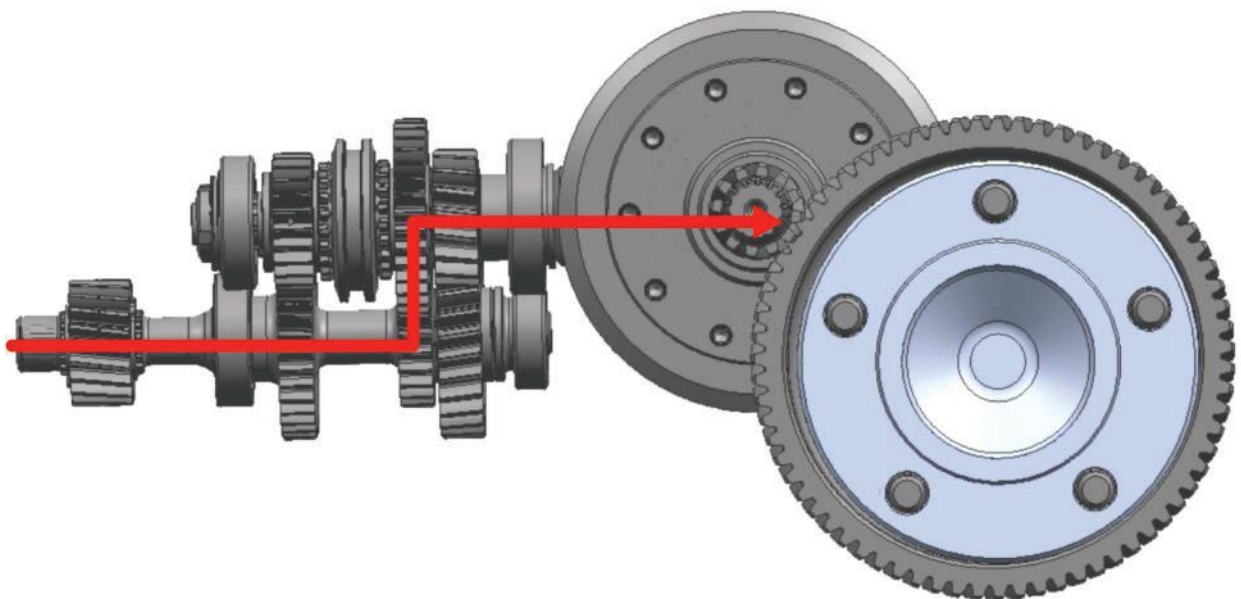

ITL000416

8. HST POWER FLOW CHART

1. Rear PTO Power Flow

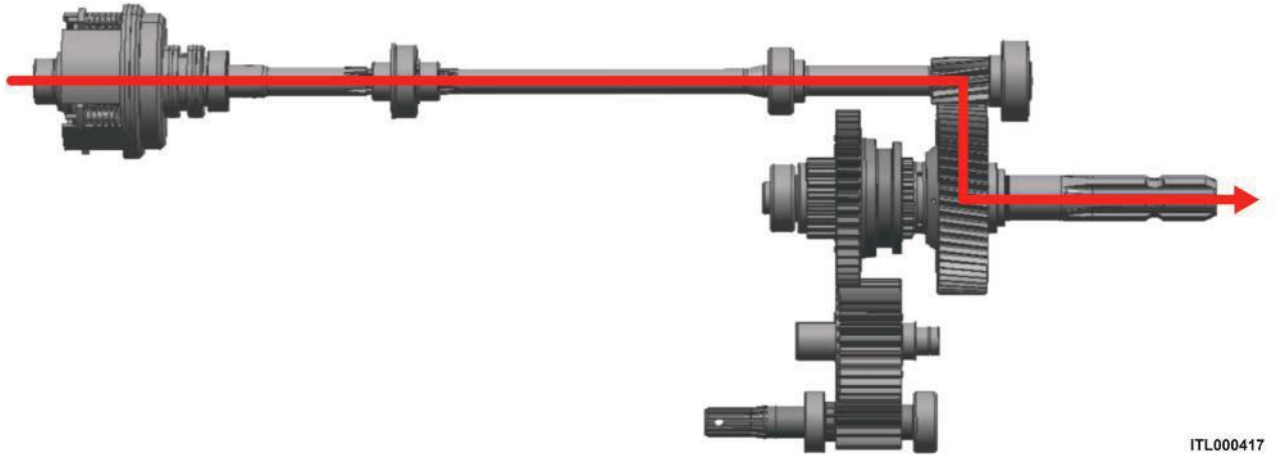

2. Mid PTO Power Flow

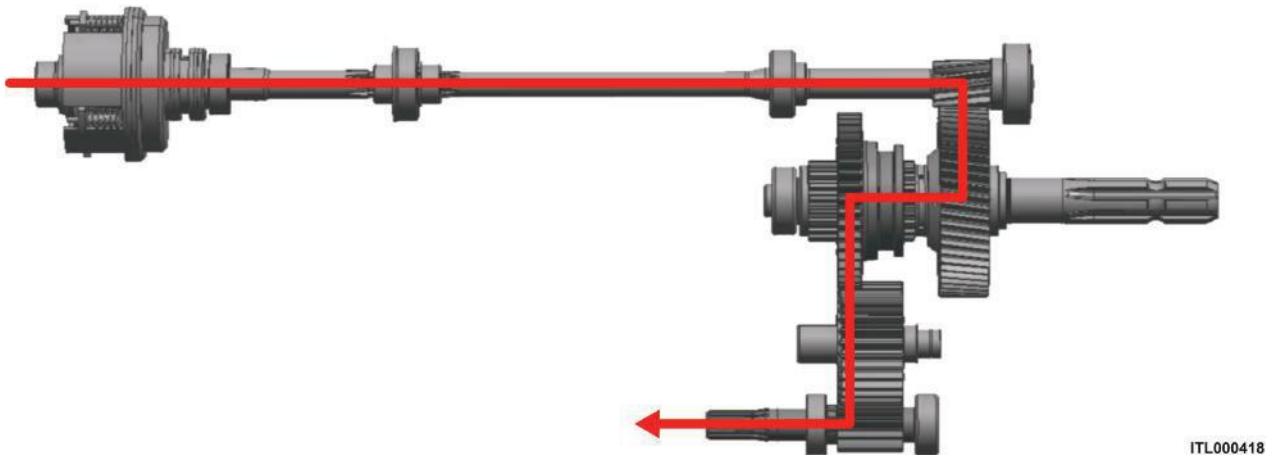

3. Both PTO Power Flow

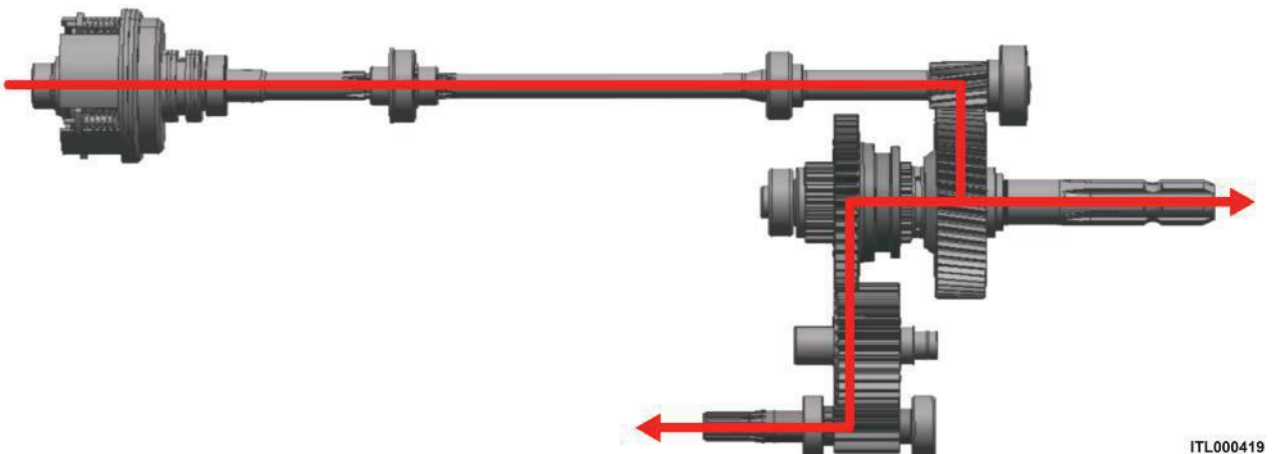

9. FILLING AND CHECKS

Draining and Checks

To Drain :-

1. Park the tractor on a leveled surface and engage parking brake.
2. Keep a vessel under the drain plugs.
3. Remove all drain plugs.
4. Re-tight the drain plugs with recommended torque after draining complete oil.

Note :- Always use new sealing washer to avoid any leakage.

Scheduled maintenance oil drain.

To drain the oil, remove the level filler and drain plug .

Fill Transmission Oil

Fill the transmission with oil to the maximum level marked on the level dipstick.

- Apply the parking brake.
- Keep the speed control in NEUTRAL range.
- Start the engine at idle RPM until oil circulate in system.
- Keep the hydraulic levers in neutral position. Shut off the engine.
- Check that the transmission oil level is in the prescribed range on the level dipstick.
- If necessary, top up with oil to keep the level in the prescribed range.

Note :- Check the oil level as per maintenance schedule.

10. SERVICE SCHEDULE

Service Schedule

Specified maintenance intervals are for standard-duty use.

Severe operating conditions may require more short intervals.

| | | | | |
|--------------------|------------------|-------------------------------|--------------------------------|-------------------|
| Legends: | | | | |
| R — Replace | C — Check | CT — Check & Tight | CA — Check & Adjust | CL — Clean |

| Operation | Recommended intervals (Hours) | | | | | | | | |
|----------------------------------------|-------------------------------|-----|-----|-----|------|------|------|------|------|
| | 50 | 250 | 500 | 750 | 1000 | 1250 | 1500 | 1750 | 2000 |
| Change the transmission/hydraulic oil | R | R | R | R | R | R | R | R | R |
| Change the oil suction strainer | CL | CL | CL | R | CL | CL | R | CL | CL |
| Change hydraulic oil filter (Suction) | R | R | R | R | R | R | R | R | R |
| Change hydraulic oil filter (Delivery) | R | R | R | R | R | R | R | R | R |
| Clean the transmission breather assy | R | R | R | R | R | R | R | R | R |

11. SPECIAL SERVICE TOOL

Special Service Tool

| HST Tooling List | | |
|------------------|-------------------------------------------------|-------------------|
| Sr. No. | Tool Description | Tool No. |
| 1 | Ball Bearing 6205 press in transmission housing | 18ME244 |
| 2 | TRB 30306 NBC (Cone & Bearing) | HST 06 |
| 3 | Withdrawl Nut M20 X 1.5 of Tail Pinion | HST 19 |
| 4 | Ball Bearing 6206 for PTO Shaft | HST 01 |
| 5 | Ball Bearing 6207 for PTO Shaft | HST 02 |
| 6 | Guiding Sleeve for oil seal press in Trumpet | HST 04 |
| 7 | Ball Bearing 6406 in Trumpet Housing | HST 10 |
| 8 | Oil Seal 50 X 68 X 10 Press in Trumpet Housing | HST 14 |
| 9 | Ball Bearing 6308 press in Trumpet Housing | HST 07 |
| 10 | Withdrawl Nut Tightning of Axle Shaft | HST 13 |
| 11 | TRB 30305 Press in Bearing Holding Plate | HST 20 |
| 12 | Oil Seal 25 X 52 X 10 Press In 4WD shaft | HST 11 |
| 13 | Ball Bearing 6304 Press In 4WD shaft | HST 11 |
| 14 | NRB Pressing in Intermediate Plate | HST 12 |
| 15 | Dowel Pin 10 * 20 Press inn Intermediate Plate | HST 09 |
| 16 | Cover for PTO Press in Transmission Housing | HST 05 |
| 17 | Oil Seal Press in Drop Box | HST 24 / 19ME 329 |
| 18 | Ball Bearing 6204 Press In Drop Box | HST 15 |

11. SPECIAL SERVICE TOOL

| Sr. No. | Tool Description | Tool No. |
|---------|--------------------------------------------------------|-----------|
| 19 | PTO Output shaft Press in Transmission Housing | HST 16 |
| 20 | Oil Seal of High Low Lug Press in Transmission Housing | HST 03 |
| 21 | Transmission Cap Pressing in Housing | HST 17 |
| 22 | Transmission Cap Pressing in Housing | HST 18 |
| 23 | Guiding Sleeve for oil seal press in Rear PTO | HST 08 |
| 24 | Oil seal press in PTO Cover | HST 21 |
| 25 | Mandrel for Dowel Pin 6 * 18 | 19 ME 322 |
| 26 | Mandrel for Dowel Pin 8* 25 | 19 ME 321 |
| 27 | Mandrel for Ball Bearing | HST 22 |
| 28 | Mandrel for Ball Bearing | HST 23 |

12. DISASSEMBLY OF PUMP

Disassembly of Pump

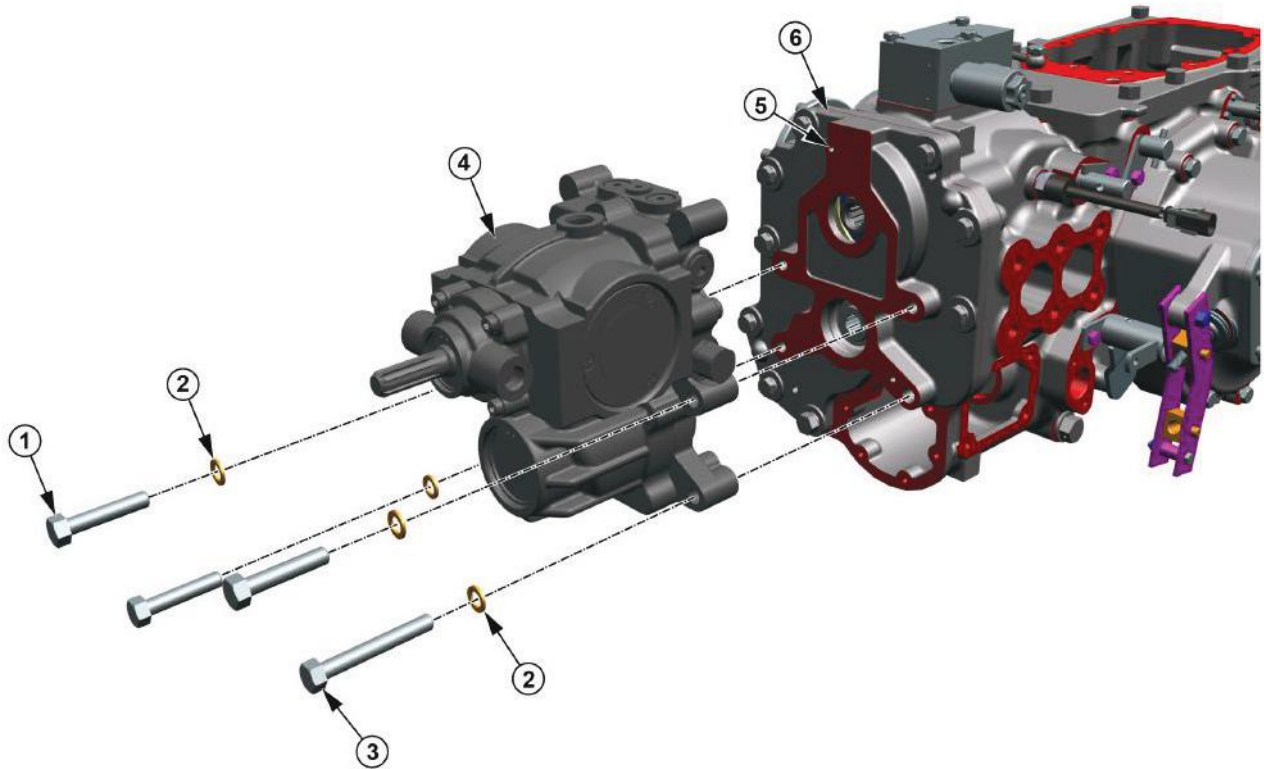

ITL000901

1 — Bolt (M12 X 1.75 X 90)

2 — Spring Washer

3 — Bolt (M12 X 1.75 X 60)

4 — Pump

5 — Dowel Pin

6 — Housing

Remove Bolt (1) , Bolt (3) and spring washer (2) from pump.

Remove pump (4) from dowel pin (5) of housing (6).

NOTE :- Follow the pump disassembly procedure for further removal of pump parts.

12. DISASSEMBLY OF PUMP

Important :

Remove dirt and dust adhering to the outside completely.

Discharge all hydraulic fluid in the HST case and the oil passage of the port block.

Use a clean and dust-free work area.

Handle the parts of the HST with care to prevent from adhering dirt and dust.

Please handle the parts with care not to damage, not to drop or not to dent by contact.

Step 1:-

Remove the charge pump

1. Remove four socket head bolts (4).
2. Remove the charge pump case (3) from the case (1) and removing the trochoid rotor ASSY, the key (5) from the shaft (6) and the O-ring (2).
3. Removing two pins (7), the plate (8), the O-ring (9) and the collar (10).

Step 2:-

Removing the port block assembly

1. Remove eight socket head bolts (11).
2. Remove the port block assembly (12).
3. Remove the valve and the spring.



Be careful not to drop the valve plate.

Be careful not to lift the cylinder blocks together.

Handle the pins carefully.

When the cylinder block does not come off, hit lightly to the port using special tool.

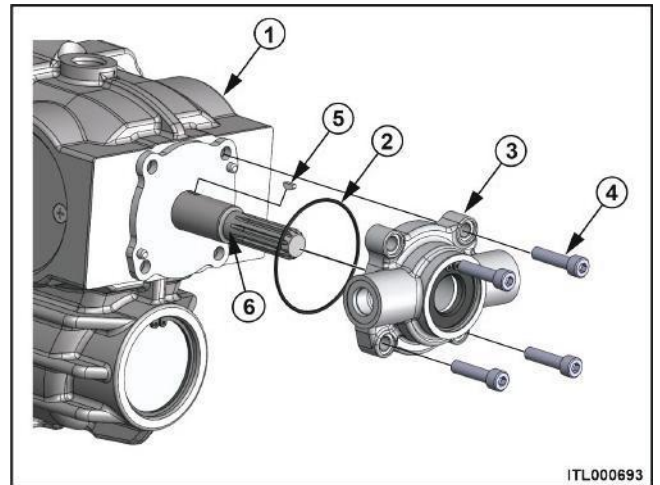

ITL000693

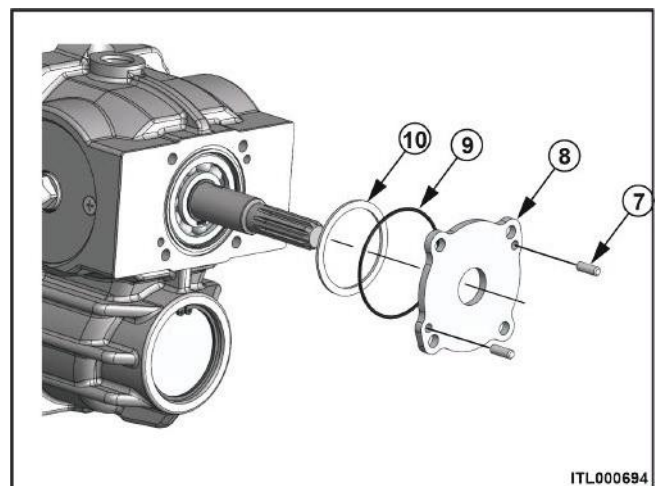

ITL000694

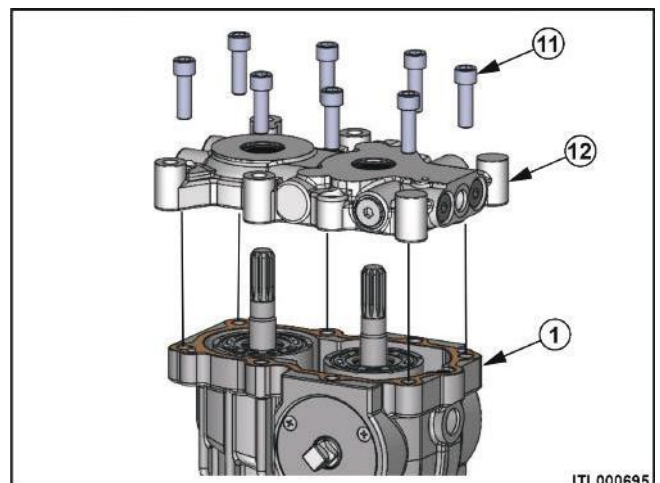

ITL000695

12. DISASSEMBLY OF PUMP

Step 3:-

Remove the valve plate

1. Remove the valve plate (13) and (14) by inserting the flathead driver into ditch part

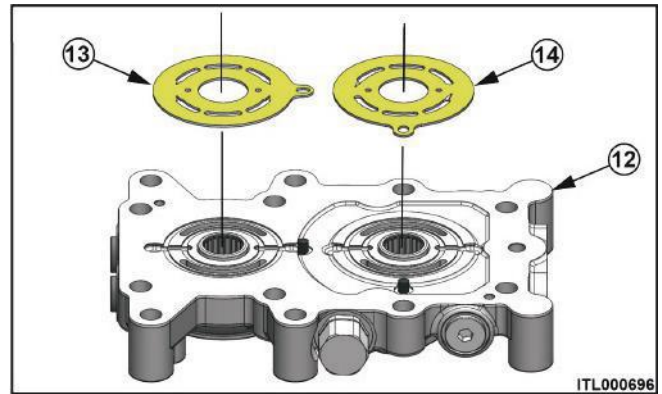

2. Remove the gasket (16) and two pins (15).

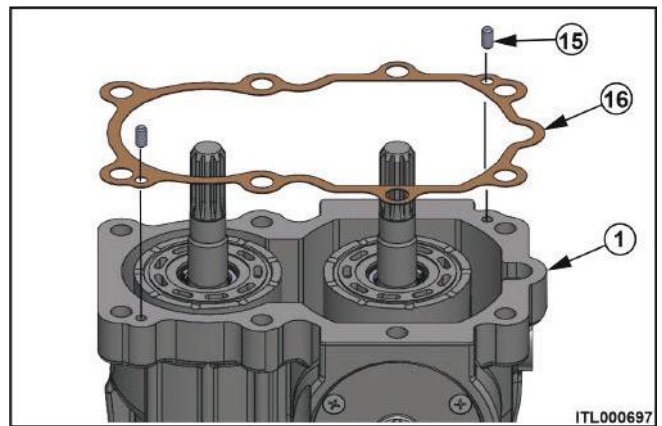

3. Remove the cylinder block (pump side) (17).

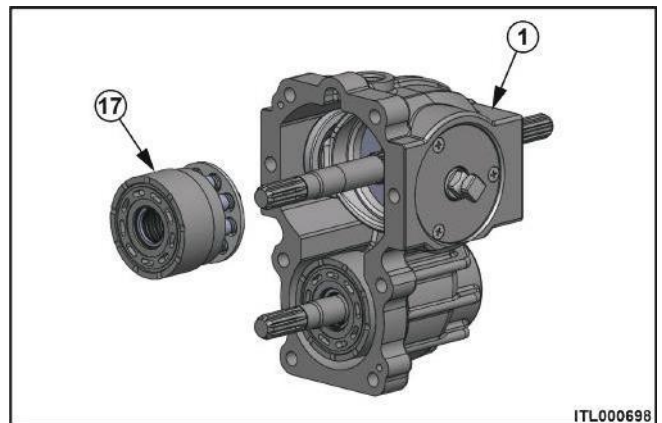

4. Remove the cylinder block (motor side) (18).

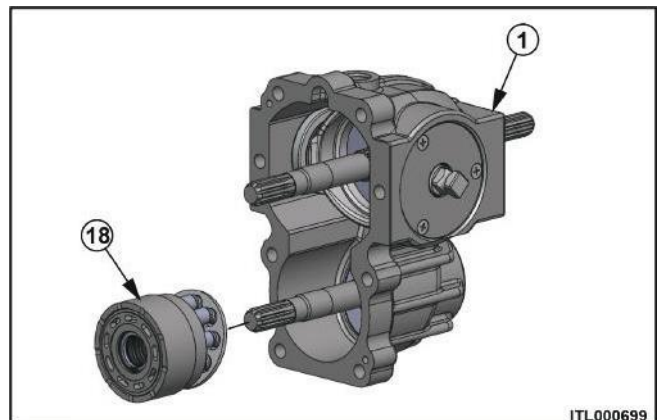

12. DISASSEMBLY OF PUMP

Step 4:-

Remove the thrust plate

1. Remove the thrust plate (19) of pump side.
2. Remove the thrust plate (20) of motor side.

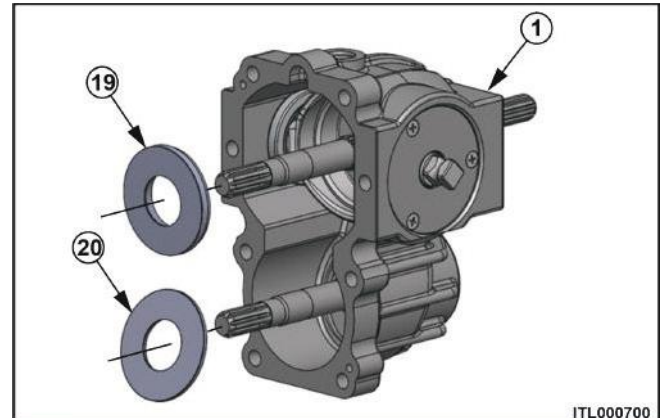

Step 5:-

Remove the shaft

Remove the pump shaft (assy)

1. Hit the pump shaft (21) end as shown in figure with a plastic hammer, and remove it from the case (1).

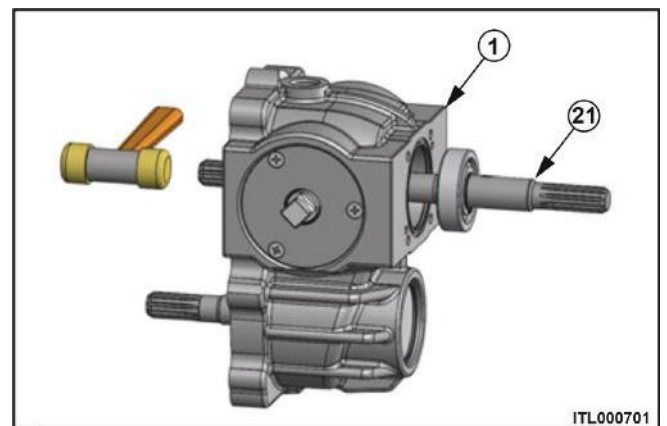

Remove the motor shaft (ASSY)

1. Remove the snap ring (22).

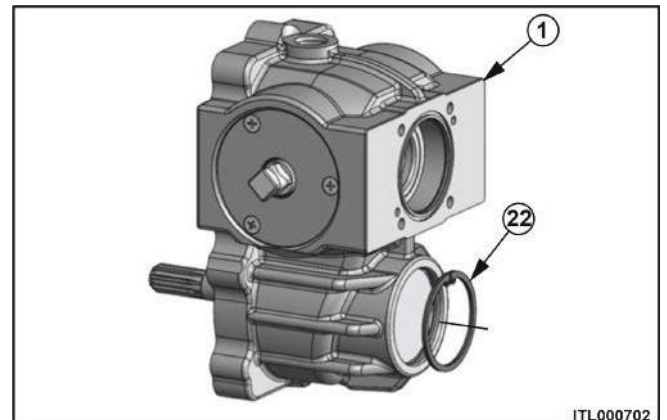

2. Hit the motor shaft (24) end as shown in the figure with a plastic hammer and remove the cap (23) from the case (1).

3. Remove the motor shaft (ASSY) (24) from the case (1).

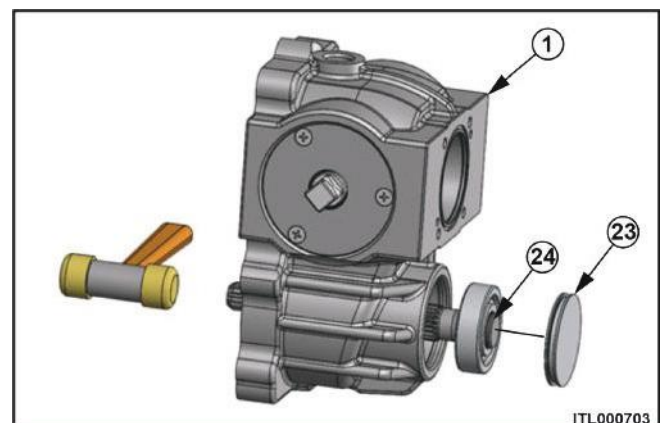

12. DISASSEMBLY OF PUMP

Step 6:-

Remove the swash plate

1. Remove six screws (25) from both sides.

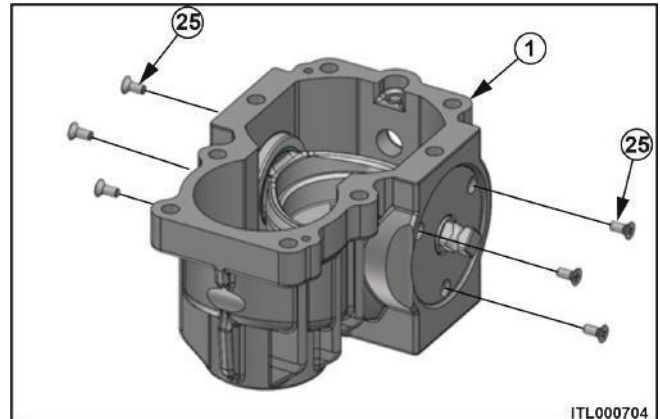

2. Hit the trunnion shaft end with a plastic hammer and the cover is floated from the case (1) and remove it from the case (1).

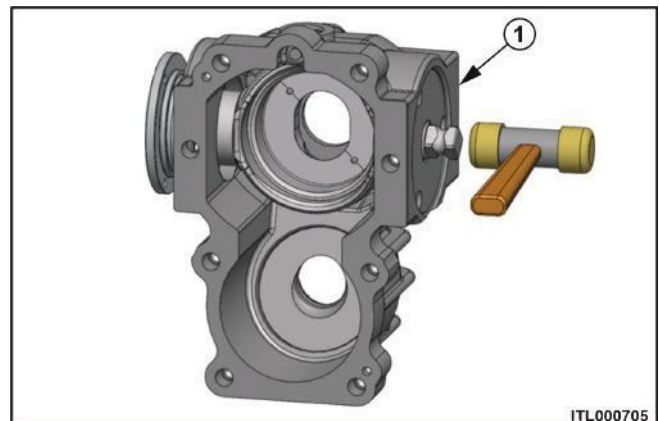

3. Hit the swash plate end as shown in the figure with a plastic hammer, and cover is floated from the case (1) and remove it from case (1).

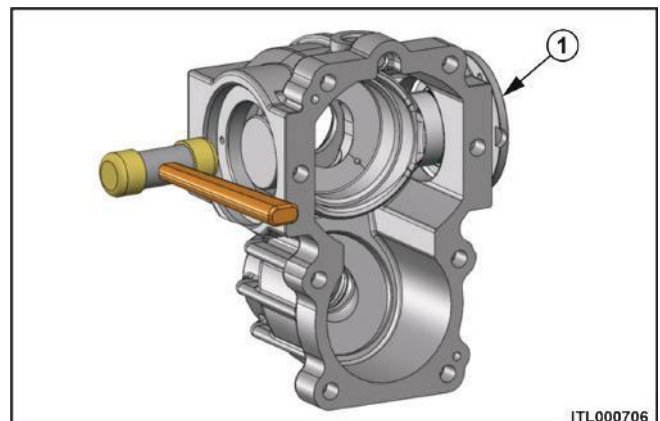

4. Remove the swash plate (26) from the case (1).

5. Remove two pins from the swash plate (26).

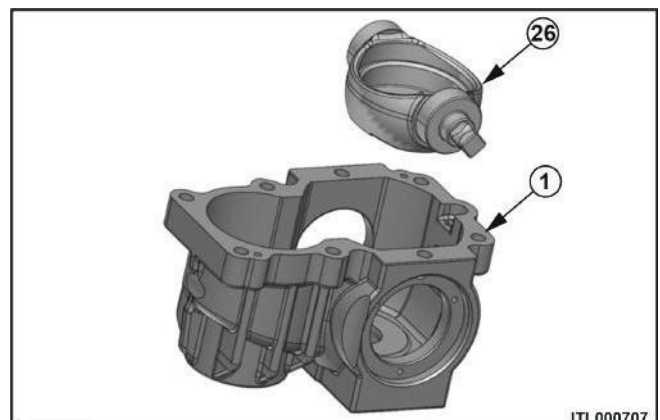

12. DISASSEMBLY OF PUMP

Disassemble of port block

1. Remove the check valves. Remove the plug , spring and poppet from both side.
2. Removing the high pressure relief valve. Remove the valve S/A.

NOTE :-

When removing the valve S/A, put a spanner on the hexagon of the valve body. If the spanner is put on the nut and turned, the valve S/A (61) will be disassembled and left in the port block.

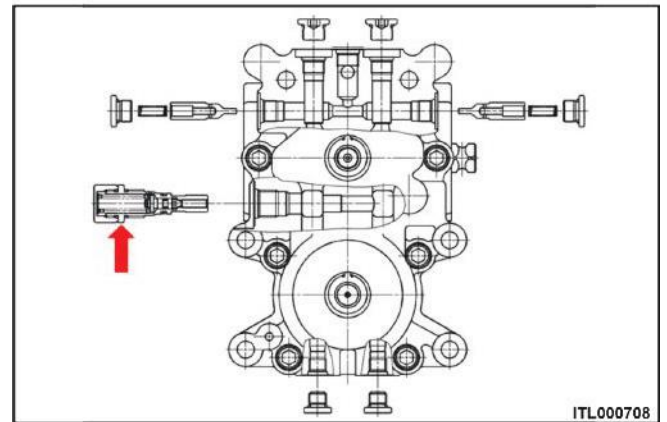

13. DISASSEMBLY OF DIFFERENTIAL HOUSING

Dis-assembly of Differential Housing

Step 1 :

1. Remove the bolts and washers (2) of trumpet housing (1).
2. Remove the rear axle (3) and trumpet housing (1) from differential housing.

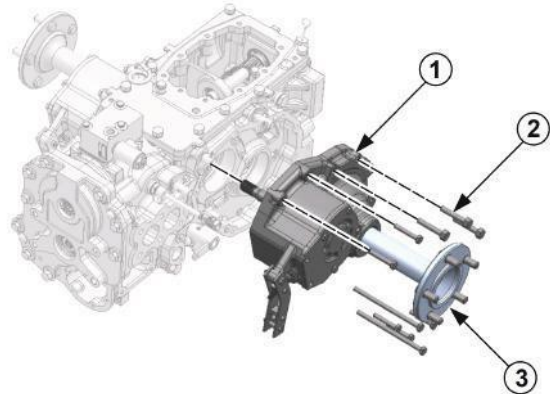

ITL000441

Step 2 :

1. Remove the bolts and washers (4).
2. Remove the PTO valve assembly (5).

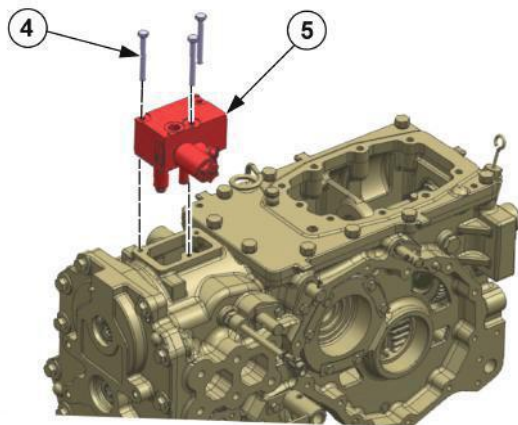

ITL000442

Step 3 :

1. Remove the bolts (6).
2. Remove the intermediate plate (7).

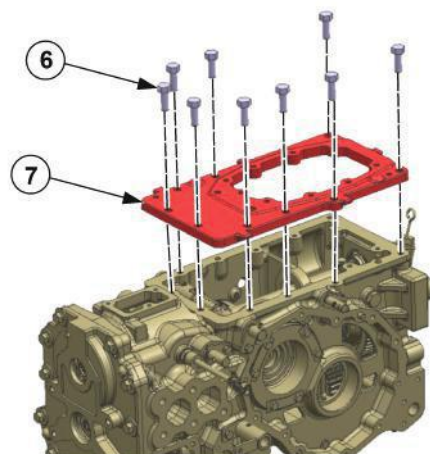

ITL000443

13. DISASSEMBLY OF DIFFERENTIAL HOUSING

Step 4 :

1. Remove three spiral pins (8) by using tool.

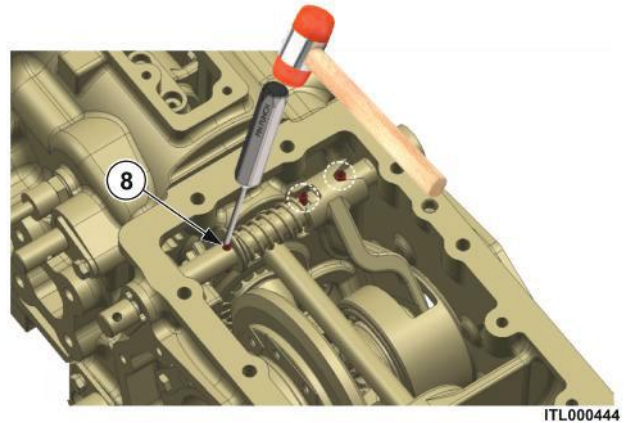

Step 5 :

1. Remove the bolt (9) and washer (10).
2. Remove the locking strip (11).

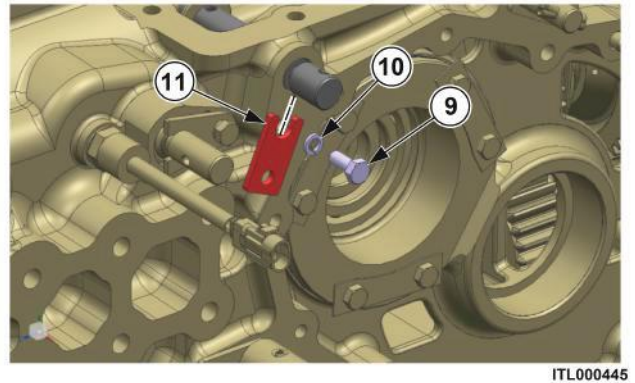

Step 6:

1. Remove the differential lock fork (12), spring (13), spacer (14) and differential lock shaft (15).

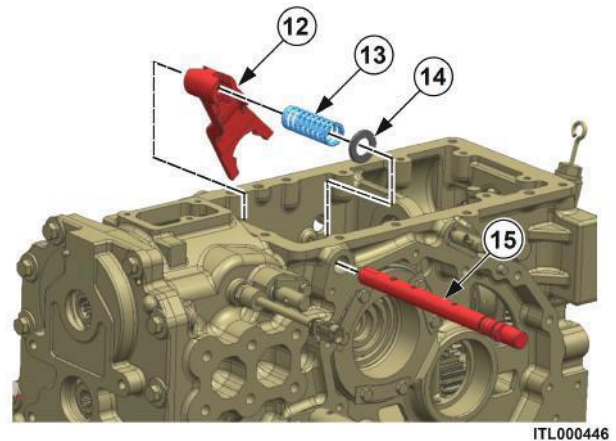

Step 7:

1. Remove the dipstick (17).

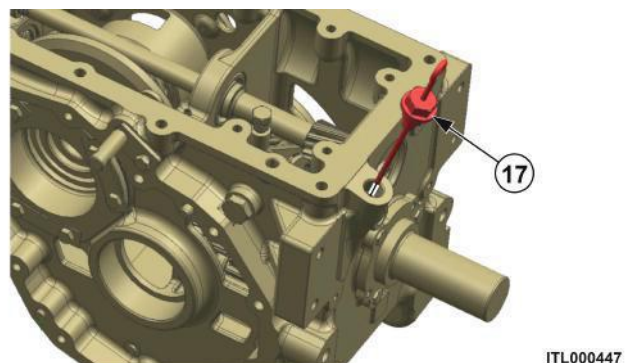

13. DISASSEMBLY OF DIFFERENTIAL HOUSING

Step 8:

1. Remove the cap (19) from differential housing.
2. Remove the internal circlip (18) by using tool.

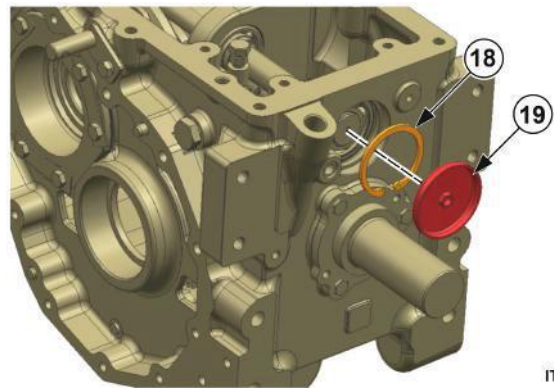

ITL000448

Step 9:

1. Remove the shim (20).

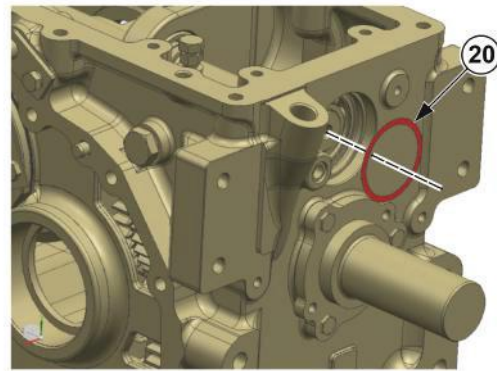

ITL000449

Step 10:

1. Remove the ball bearing 6206 (23).
2. Remove the PTO intermediate shaft (21) and ball bearing 6205 (22).

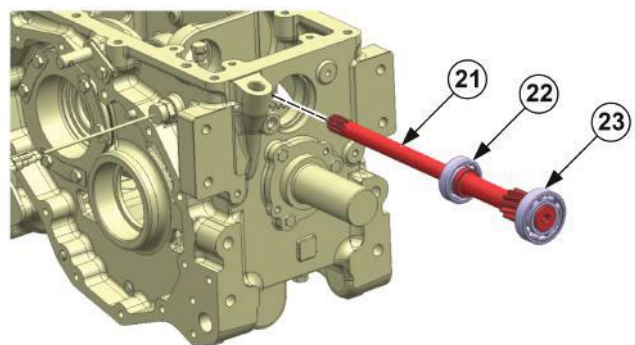

ITL000450

Step 11:

1. Remove the PTO switch (25) and bonded seal (24).

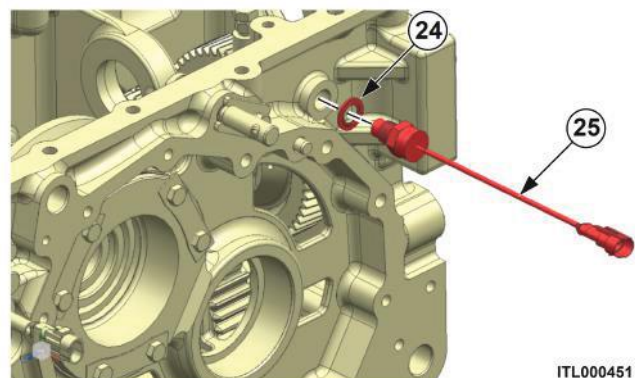

ITL000451

13. DISASSEMBLY OF DIFFERENTIAL HOUSING

Step 12:

1. Remove the parking brake switch (26) and bonded seal (24).

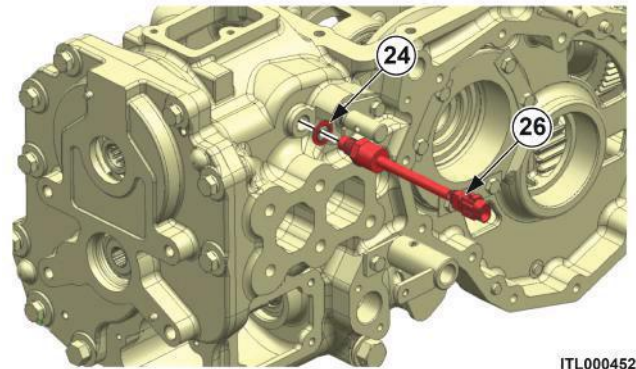

ITL000452

Step 13:

1. Remove the bolts (27) and locking plates (28) on both sides.

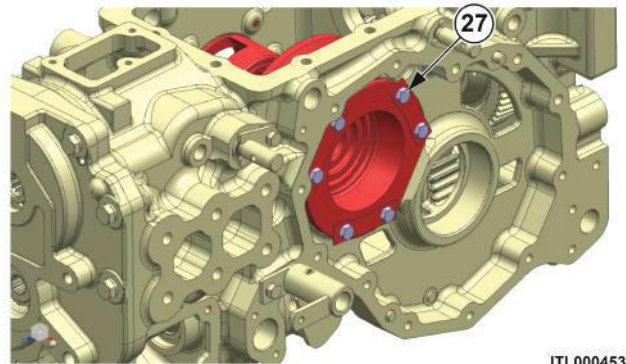

ITL000453

Step 14:

1. Remove the differential cage (29) and shims (30) from both sides.

Note :- Attach the shims with respective cage to avoid interchange.

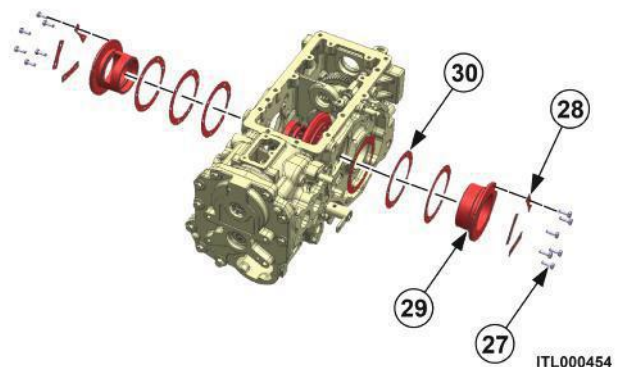

ITL000454

Step 15:

1. Remove the differential cage assembly (31).

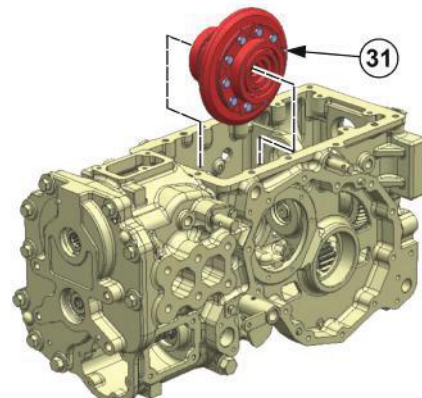

ITL000455

13. DISASSEMBLY OF DIFFERENTIAL HOUSING

Step 16:

1. Remove the bolts (33).
2. Remove the intermediate plate (32).

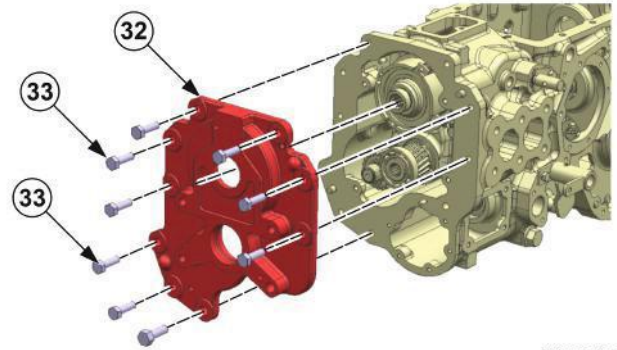

ITL000456

Step 17:

1. Remove the bolt (34) and washer (35).
2. Remove the locking strip (36).

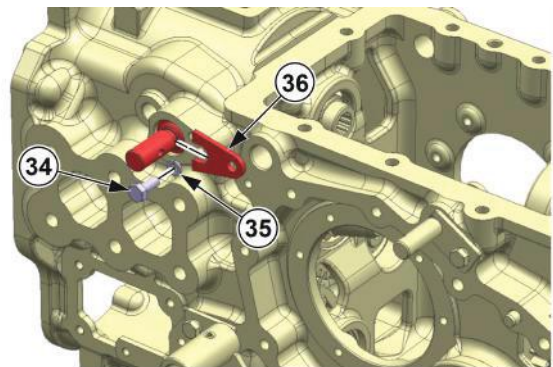

ITL000457

Step 18:

1. Remove the PTO clutch assembly (37).

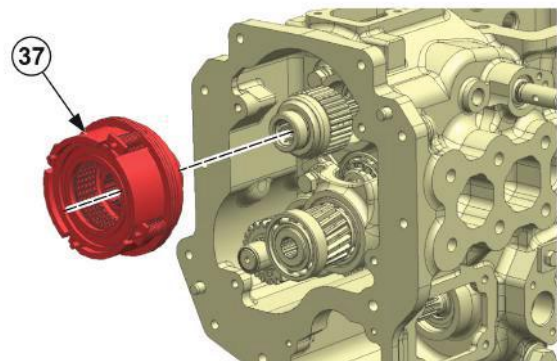

ITL000458

Step 19:

1. Remove hub PTO clutch (38).

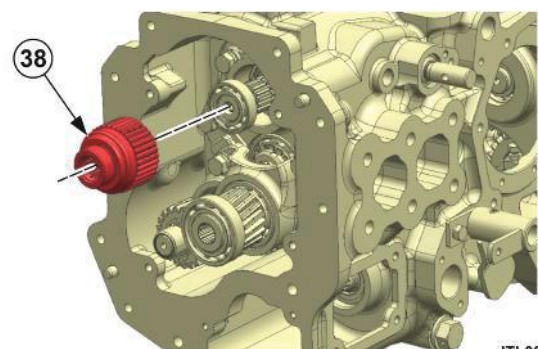

ITL000459

13. DISASSEMBLY OF DIFFERENTIAL HOUSING

Step 20:

1. Remove the ball bearing 6005 (39).

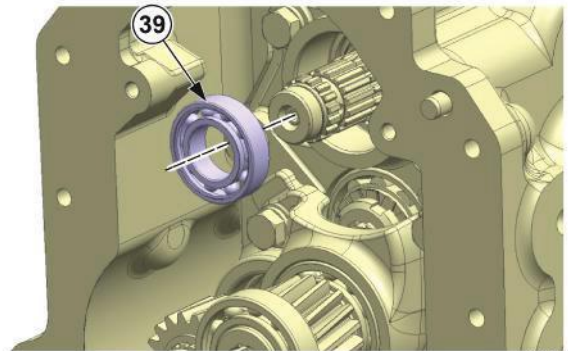

ITL000460

Step 21:

1. Remove the ball bearing 6007 (40).

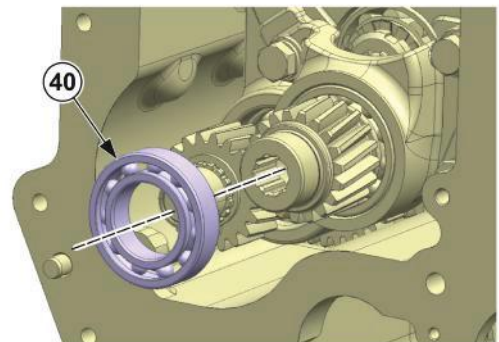

ITL000461

Step 22:

1. Remove the needle bush (41).

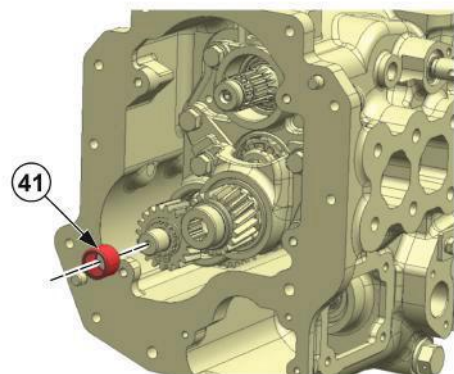

ITL000462

Step 23:

1. Remove the circlip (42).

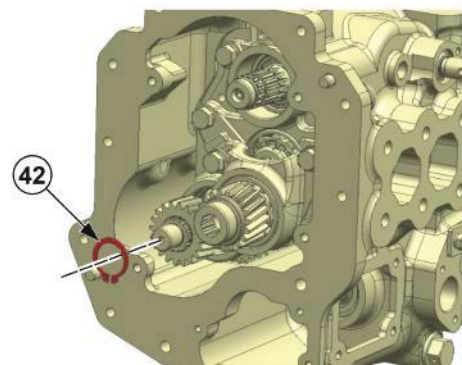

ITL000463

13. DISASSEMBLY OF DIFFERENTIAL HOUSING

Step 24:

1. Remove the driven gear Z-20 (43).

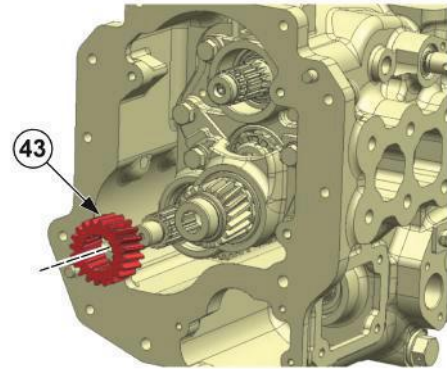

ITL000464

Step 25:

1. Remove the circlip (44).

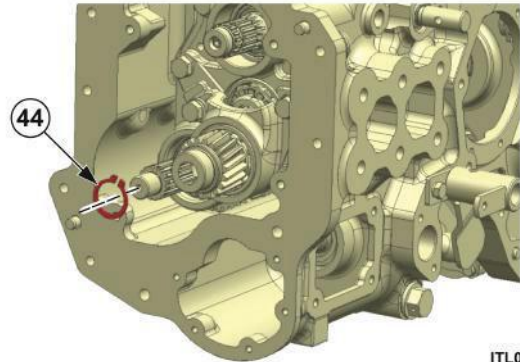

ITL000465

Step 26:

1. Remove driven gear Z-19 (45).

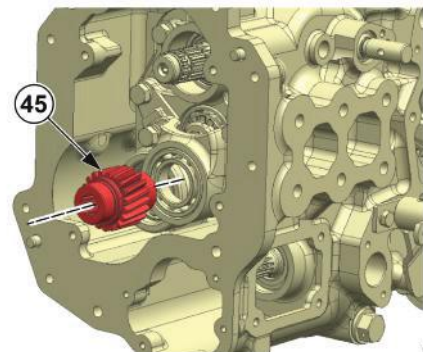

ITL000466

Step 27:

1. Remove the three bolts (47).
2. Remove the bearing holder bracket (46) and ball bearing 6007 (48).

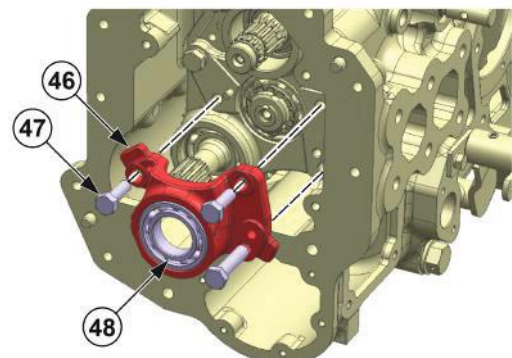

ITL000467

13. DISASSEMBLY OF DIFFERENTIAL HOUSING

Step 28:

1. Unlock the locking washer (50) with the help of flat screw driver and remove the withdrawal nut (49) and locking washer (50)

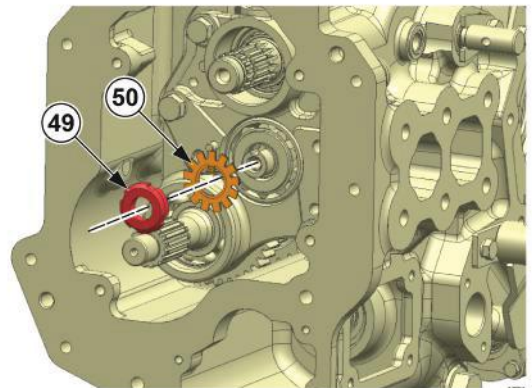

ITL000468

Step 29:

1. Remove the bolts (51) of bearing holder plate (52).
2. Remove the bearing holder plate (52).

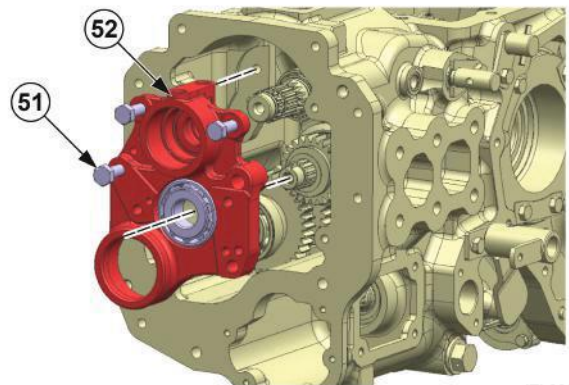

ITL000469

Step 30:

1. Remove the taper roller bearing (53) from bearing holder plate (52).

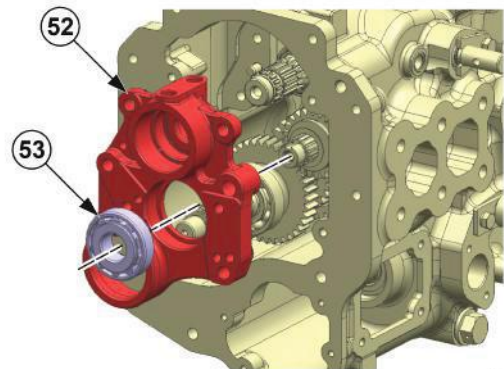

ITL000470

Step 31:

1. Remove the circlip (54), shim (55) and thrust washer (56).

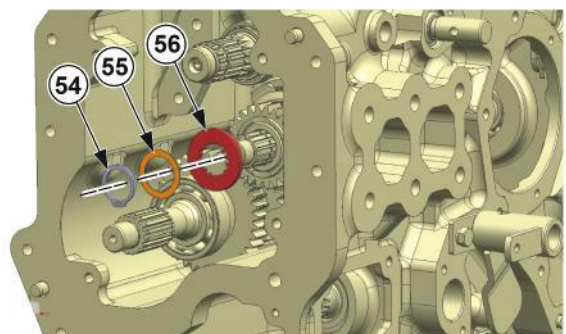

ITL000474

13. DISASSEMBLY OF DIFFERENTIAL HOUSING

Step 32:

1. Remove the dog gear high Z-24 (57).

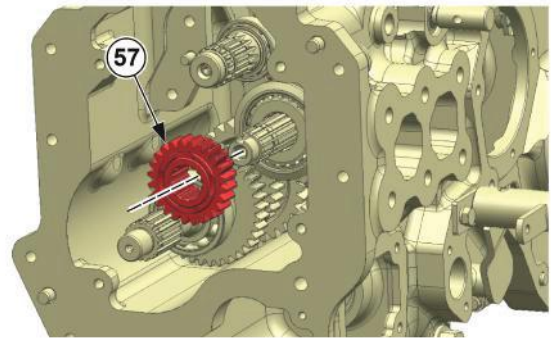

ITL000475

Step 33:

1. Remove the spiral pin (58) by using tool.

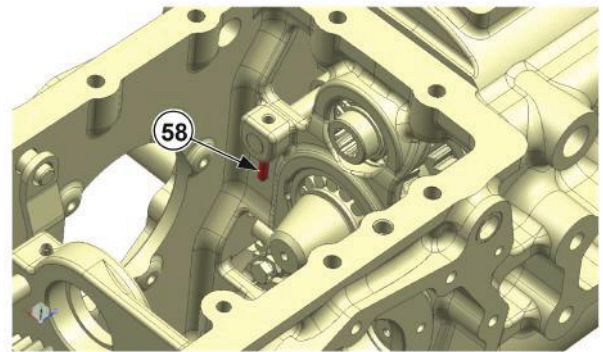

ITL000476

Step 34:

1. Remove the shifter rod (59) from differential housing

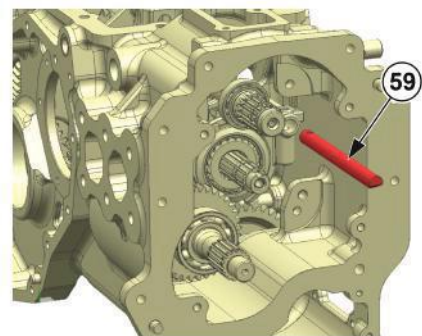

ITL000471

Step 35:

1. Remove the shifter lug (60) from differential housing.

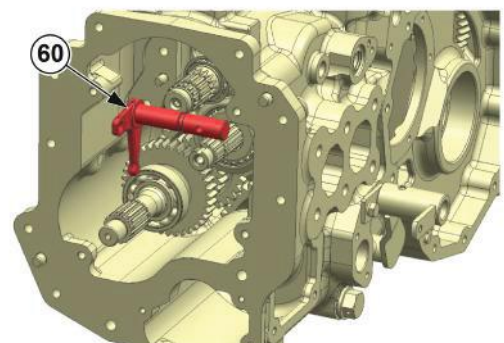

ITL000472

13. DISASSEMBLY OF DIFFERENTIAL HOUSING

Step 36:

1. Remove the tail pinion shaft (61) and taper roller bearing (62).

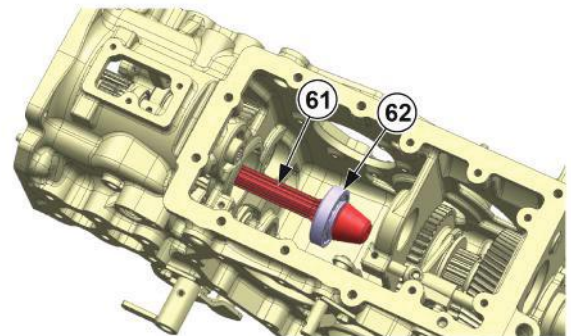

ITL000473

Step 37:

1. Remove the shifter sleeve (63), hub (67), fork (64), dog gear low (65) and driver gear 4WD (66).

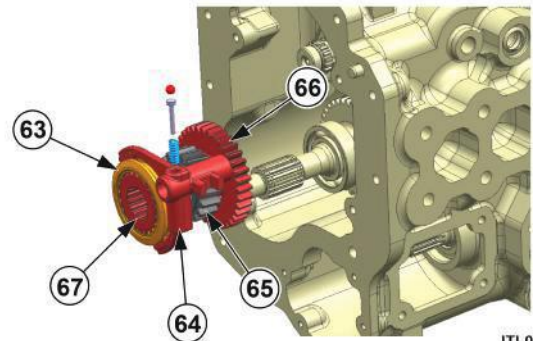

ITL000477

Step 38:

1. Remove the PTO drive shaft (68) and ball bearing 6005 (69).

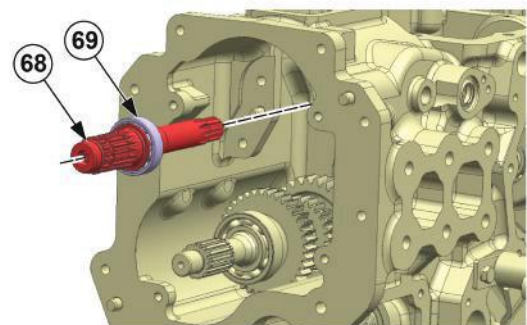

ITL000478

Step 39:

1. Remove the shim (70) from PTO drive shaft.

Note :- Tie the shim (70) with respective part to avoid interchange.

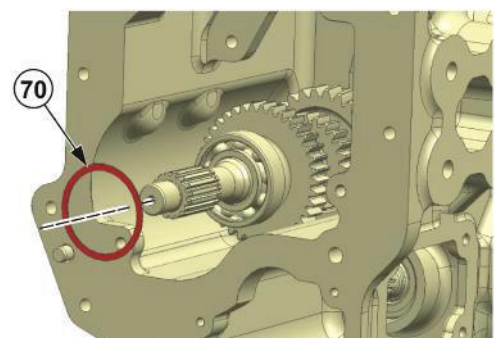

ITL000479

13. DISASSEMBLY OF DIFFERENTIAL HOUSING

Step 40:

1. Remove the ball bearing 6206 (71), range lay shaft (72), idler gear 4WD (73).

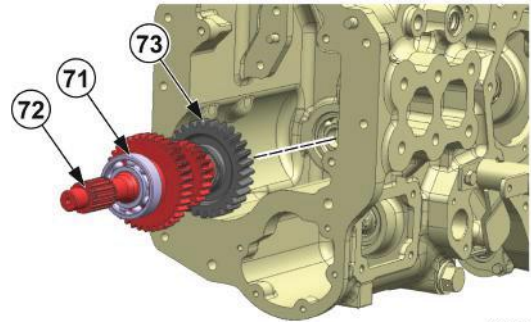

ITL000480

Step 41:

1. Remove the ball bearing 6304 (74).

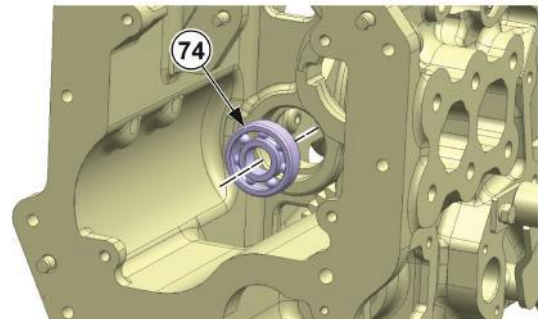

ITL000481

Step 42:

1. Remove the internal circlip (75) from differential housing.
2. Remove the external circlip (76) from connecting sleeve PTO.

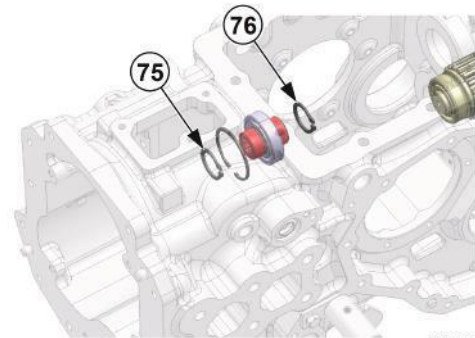

ITL000482

Step 43:

1. Remove the connecting sleeve PTO (77) and ball bearing (78).

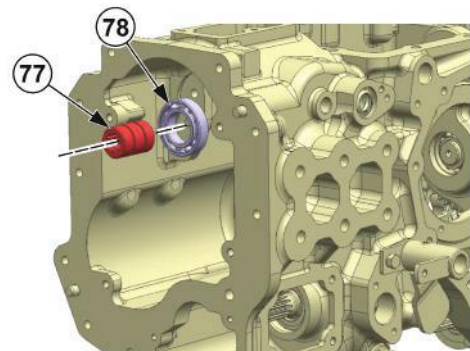

ITL000483

13. DISASSEMBLY OF DIFFERENTIAL HOUSING

Step 44:

1. Remove the spiral pin (79) by using tool.

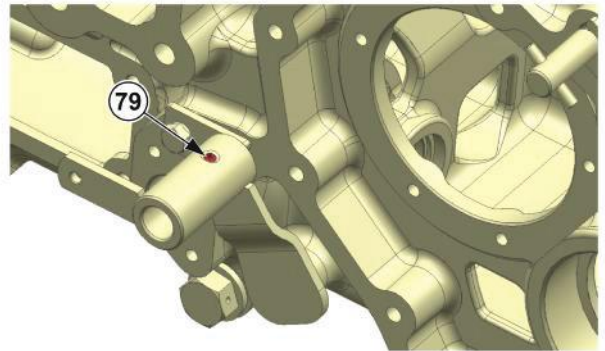

ITL000484

Step 45:

1. Remove the pivot lug (80), ball (81) and spring (82).

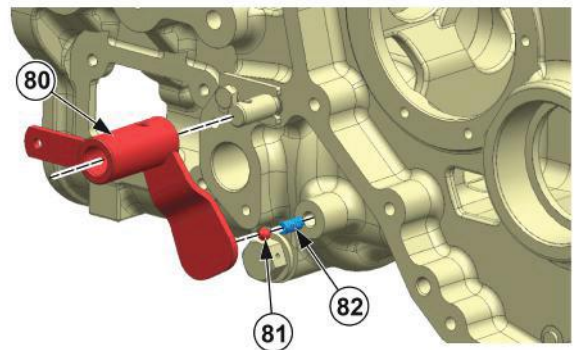

ITL000485

Step 46:

1. Remove the bolt (83).
2. Remove the locking plate (84).

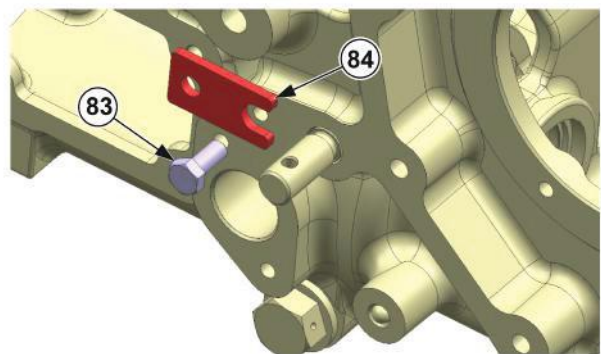

ITL000486

Step 47:

1. Remove the bolt (85) and nut from fork (86).

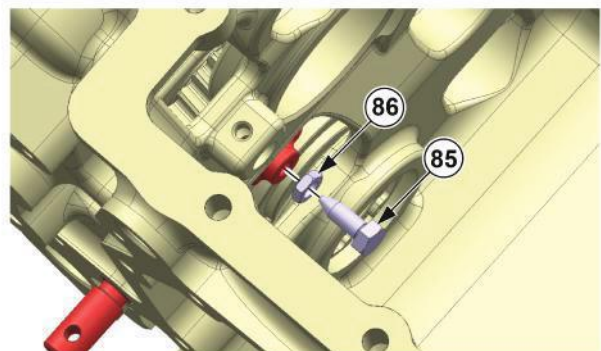

ITL000487

13. DISASSEMBLY OF DIFFERENTIAL HOUSING

Step 48:

1. Remove the pivot rod (87).

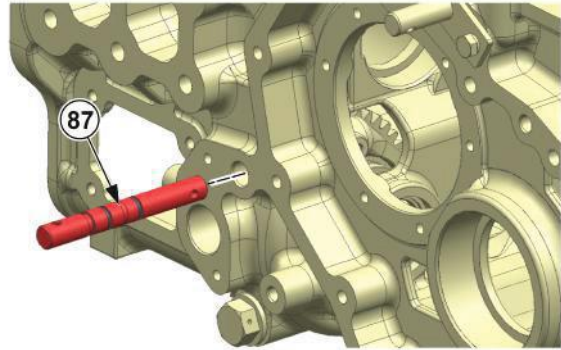

ITL000488

Step 49:

1. Remove the fork 4WD (88).

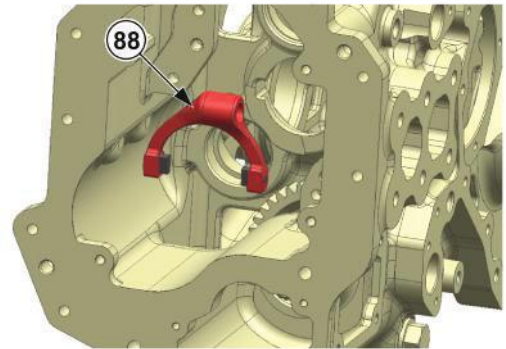

ITL000489

Step 50:

1. Remove the internal circlip (89)

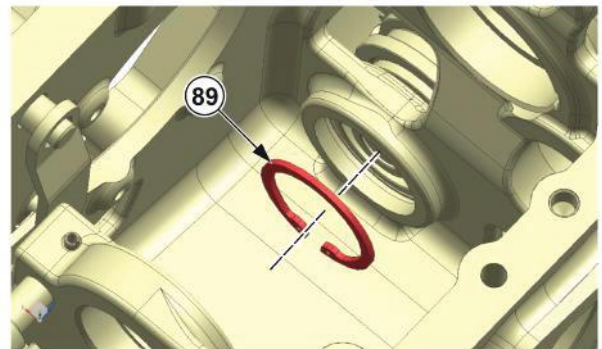

ITL000490

Step 51:

1. Remove the ball bearing 6304 (90), spacer (91) and 4WD output shaft (92).

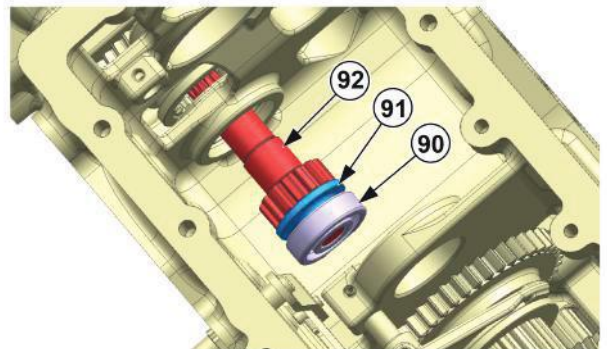

ITL000491

13. DISASSEMBLY OF DIFFERENTIAL HOUSING

Step 52:

1. Remove the driven gear 4WD (93).

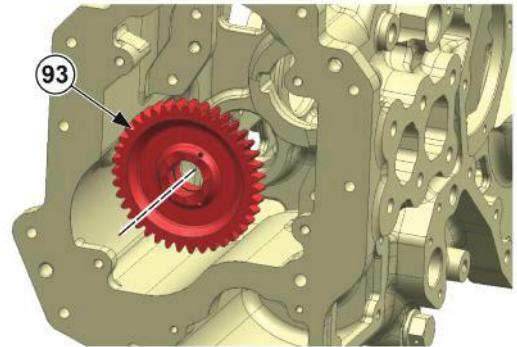

ITL000492

Step 53:

1. Remove the shifter sleeve 4WD (94).

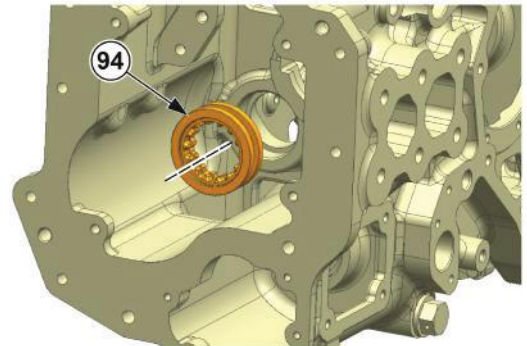

ITL000493

Step 54:

1. Remove the oil seal (95).

NOTE :- Discard the oil Seal and replace with new one during assembly.

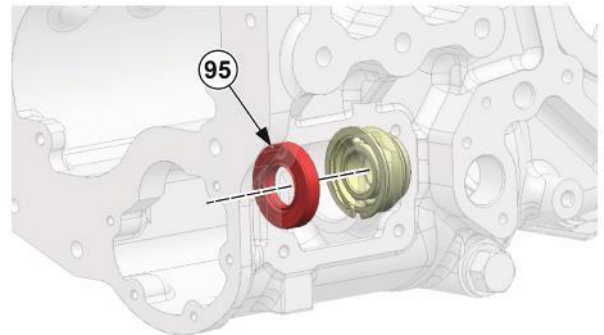

ITL000494

Step 55:

1. Remove the internal circlip (96) from differential housing.

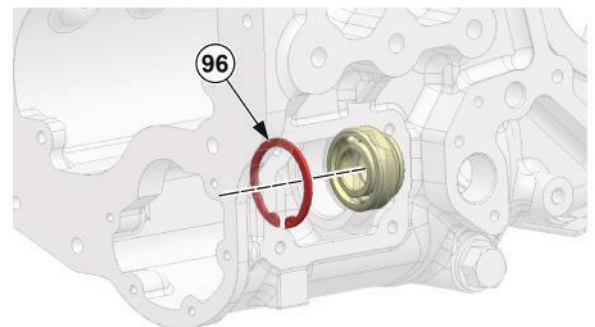

ITL000495

13. DISASSEMBLY OF DIFFERENTIAL HOUSING

Step 56:

1. Remove the ball bearing (97) and spacer (98).

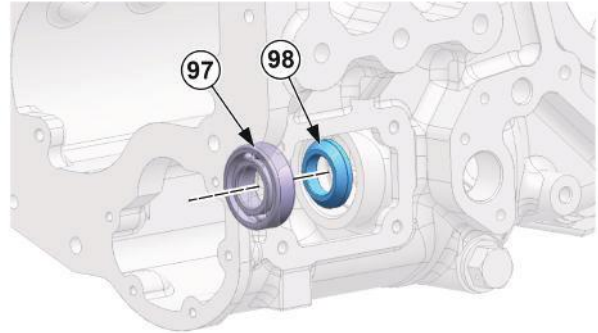

ITL000496

Step 57:

1. Remove the bolt (99) and washer (100).
2. Remove the locking plate (101).

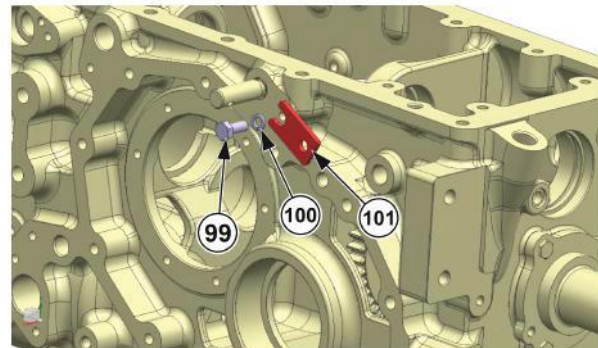

ITL000497

Step 58:

1. Remove the bolt (102) and nut (103).
2. Remove the spring (104) and ball (105).

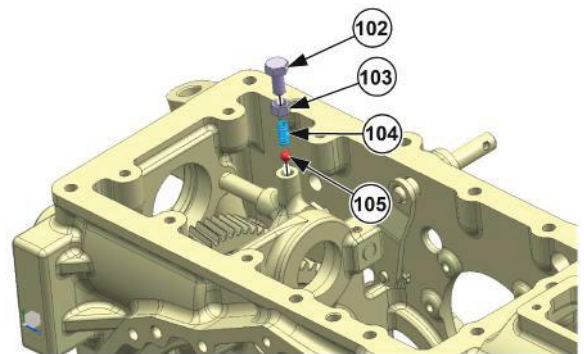

ITL000498

Step 59:

1. Remove the spiral pin (106).

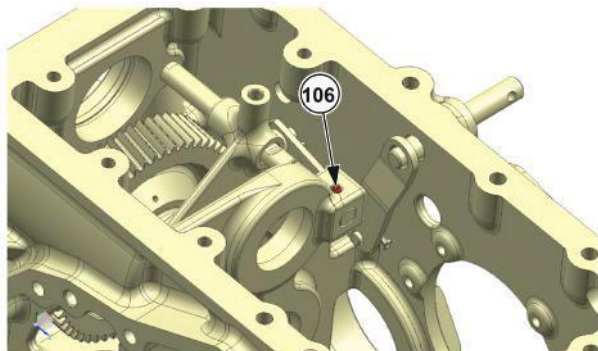

ITL000499

13. DISASSEMBLY OF DIFFERENTIAL HOUSING

Step 60:

1. Remove the circlip (109) from its location.
2. Remove the PTO shifter rod (108) along with cap (107).

NOTE :- Always replace the cap (107) with a new one.

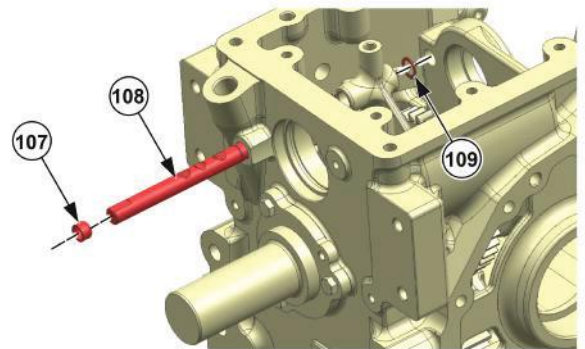

ITL000500

Step 61:

1. Remove the split pin (110).

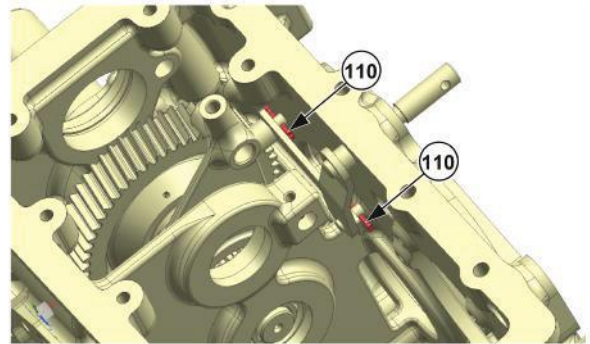

ITL000501

Step 62:

1. Remove the link PTO shifter (112) and pivot lug (111).

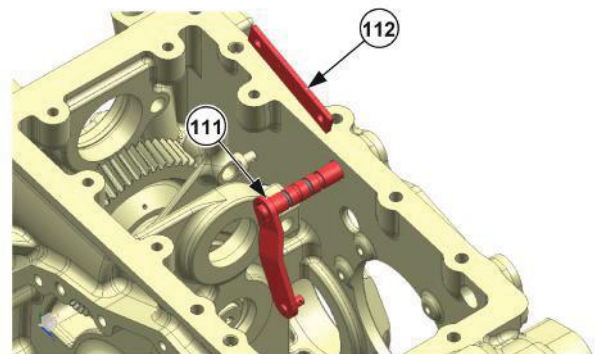

ITL000502

Step 63:

1. Remove the PTO fork (113).

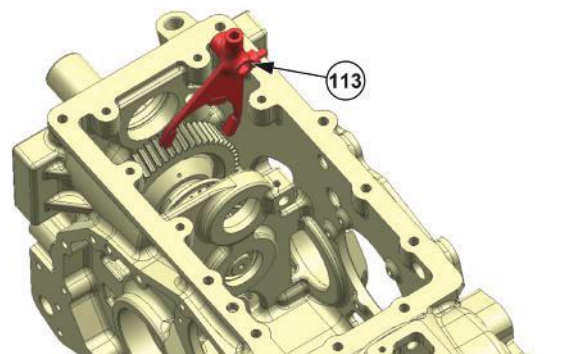

ITL000503

13. DISASSEMBLY OF DIFFERENTIAL HOUSING

Step 64:

1. Remove the PTO cap (114).

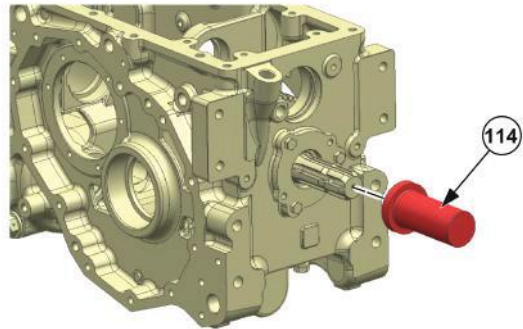

ITL000504

Step 65:

1. Remove the bolts (115) of PTO output cover (116).

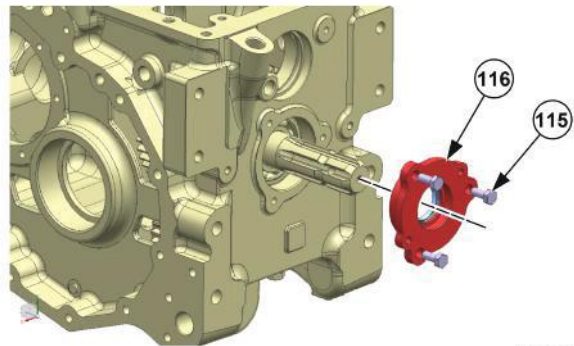

ITL000505

Step 66:

1. Remove the shim (117).

NOTE :- Tie the shim (117) with PTO output cover (116) to avoid interchanging.

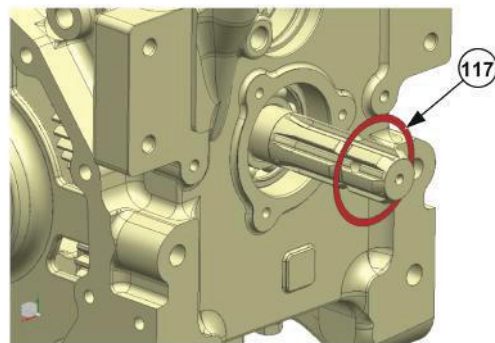

ITL000506

Step 67:

1. Remove the ball bearing 6207 (118) and PTO output shaft (119).

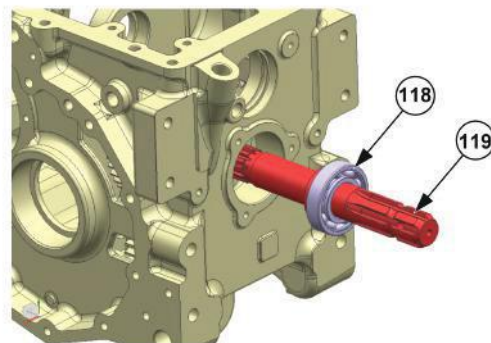

ITL000507

13. DISASSEMBLY OF DIFFERENTIAL HOUSING

Step 68:

1. Remove the hub (121), sliding gear (120) and fixed gear (119).

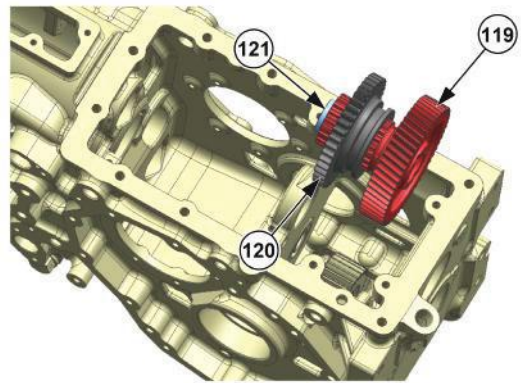

ITL000508

Step 69:

1. Remove the bolts (122).
2. Remove the mid PTO sub assembly (123).

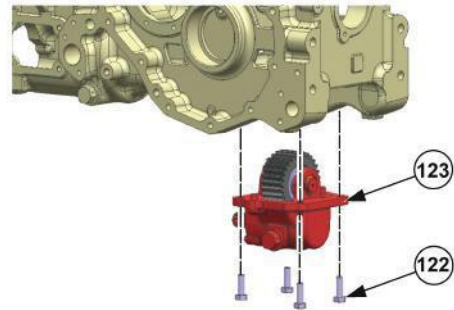

ITL000509

Dis-assembly of Mid PTO sub assembly

Step 1:

1. Remove the circlip (2) of idler shaft (3).

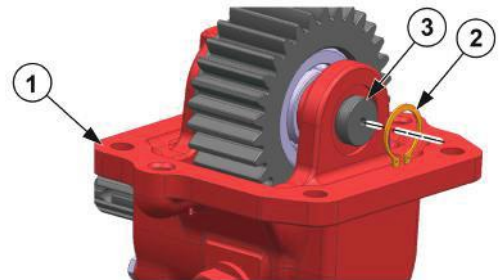

ITL000512

Step 2:

1. Remove the idler shaft (3).



ITL000513

13. DISASSEMBLY OF DIFFERENTIAL HOUSING

Step 3:

1. Remove the idler gear assembly (4).

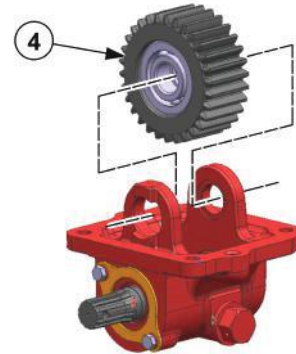

ITL000514

Step 4:

1. Remove the ball bearings (6), circlip (7), spacer (8) and shim (9) from idler gear (5).

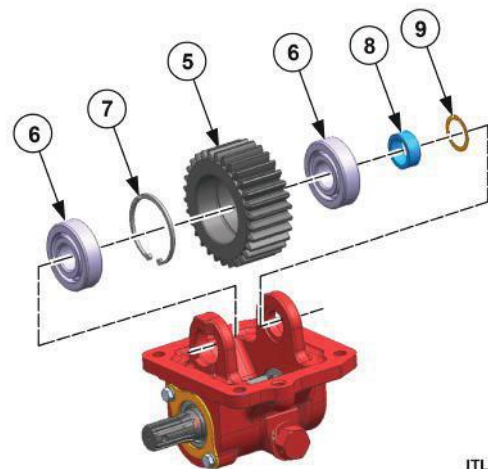

ITL000515

Step 5:

1. Remove the bolts (10).

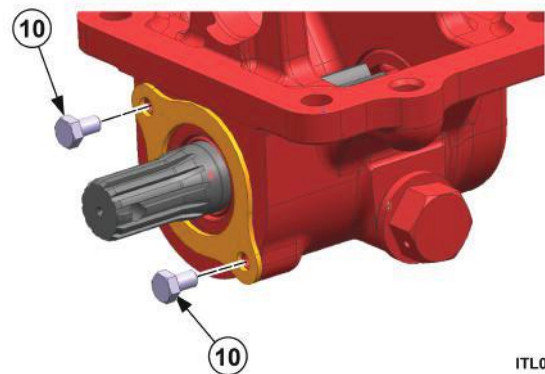

ITL000516

Step 6:

1. Remove the seal stopper (11).

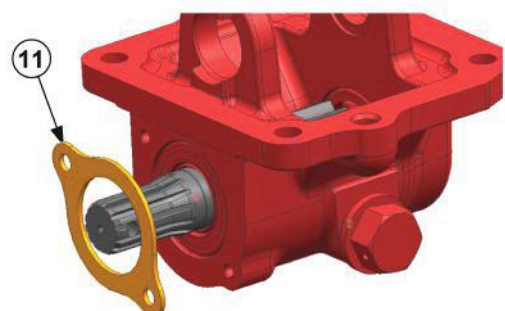

ITL000517

13. DISASSEMBLY OF DIFFERENTIAL HOUSING

Step 7:

1. Remove the oil seal (12), internal circlip (13) and shim (14).

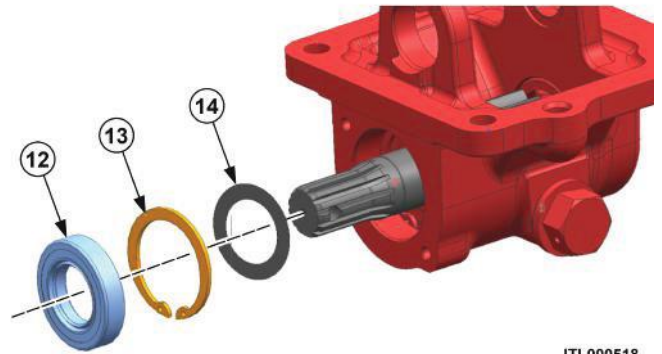

ITL000518

Step 8:

1. Remove the ball bearing 6005 (15).

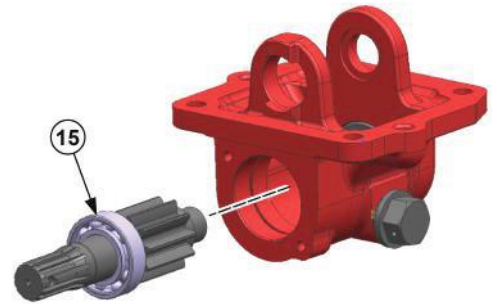

ITL000519

Step 9:

1. Remove the ball bearing 6204 (16).

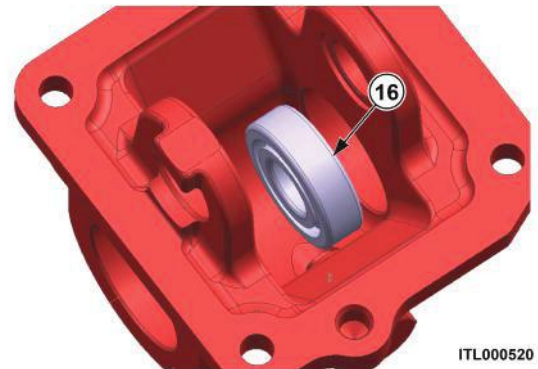

ITL000520

14. DISASSEMBLY OF TRUMPET HOUSING

Disassembly of Trumpet Housing

Step 1:

1. Unlock the locking washer by using tool and remove the locking nut (1).



ITL000521

Step 2:

1. Remove the locking washer (2), spacer (3), bearing(4), bull gear (5) and sleeve (6).

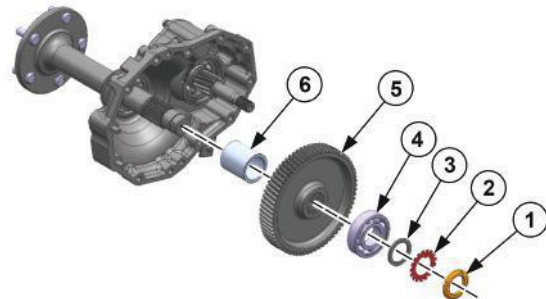

ITL000522

Step 3:

1. Remove the rear axle (7) and oil seal. Discard the oil Seal and replace with new one during assembly.



ITL000523

Step 4:

1. Remove the bolts (9) , washer (10) and brake cover (8).

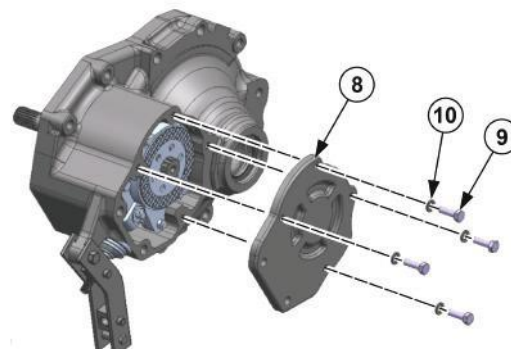

ITL000524

14. DISASSEMBLY OF TRUMPET HOUSING

Step 5:

1. Remove the split pin (11) and the bolt (12) of brake actuating rod.

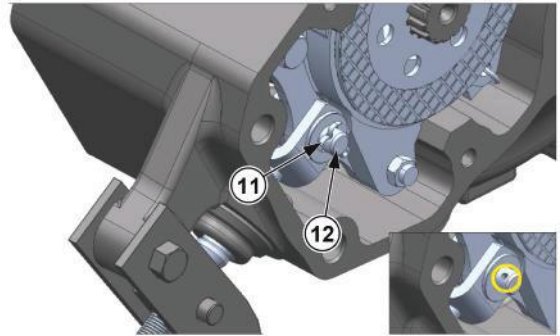

ITL000525

Step 6:

1. Remove the brake assembly (13).

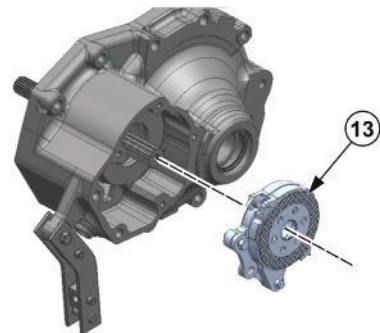

ITL000526

Step 7:

1. Remove the brake actuating rod (14).

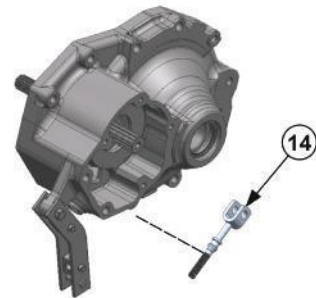

ITL000527

Step 8:

1. Remove the circlip (15) of bull shaft bearing.
2. Remove the bull shaft (16), spacer (17) and bearing (18) and circlip (19).

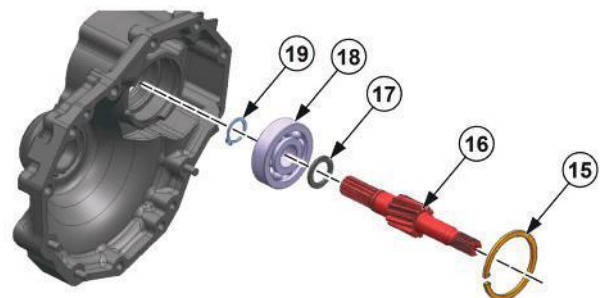

ITL000528

15. DISASSEMBLY OF TAIL PINION SHAFT

Disassembly of Tail Pinion Shaft

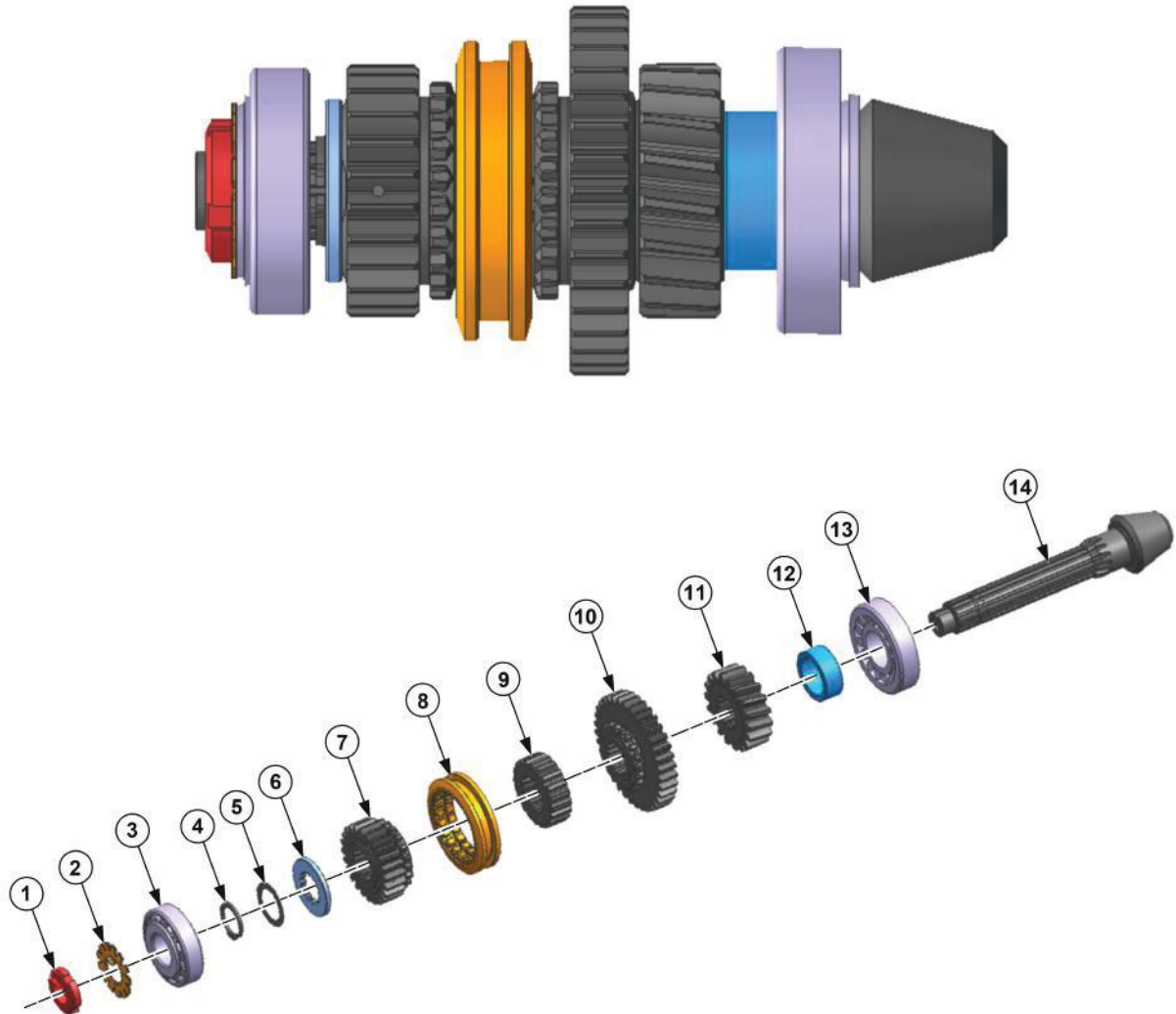

ITL000529

- 1 — Withdrawal Nut
- 2 — Locking Washer
- 3 — Taper Roller Bearing
- 4 — External Circlip
- 5 — Shim
- 6 — Thrust Washer
- 7 — Dog Gear High Z-24

- 8 — Shifter Sleeve
- 9 — Hub
- 10 — Dog Gear Low Z-35
- 11 — Driver Gear 4WD
- 12 — Spacer
- 13 — Taper Roller Bearing
- 14 — Tail Pinion Shaft

15. DISASSEMBLY OF TAIL PINION SHAFT

Step 1 :

1. Remove the withdrawal nut (1).



ITL000530

Step 2:

1. Remove the locking washer (2).

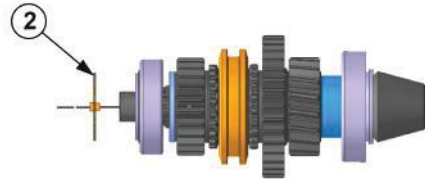

ITL000531

Step 3:

1. Remove the taper roller bearing (3).

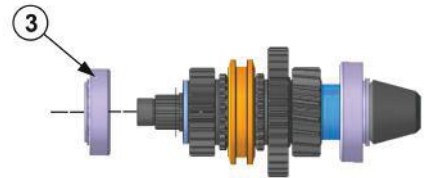

ITL000532

Step 4:

1. Remove the circlip (4).

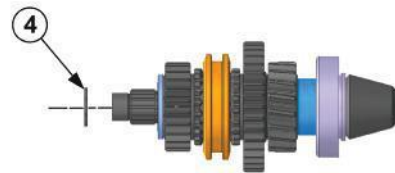

ITL000533

Step 5:

1. Remove the shim (5).

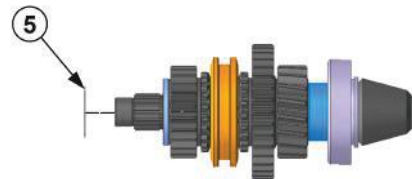

ITL000534

Step 6:

1. Remove the thrust washer (6).

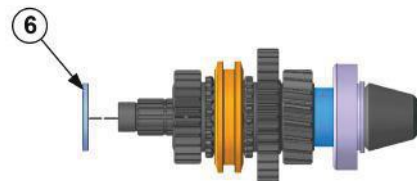

ITL000535

Step 7:

1. Remove the dog gear high Z-24 (7).

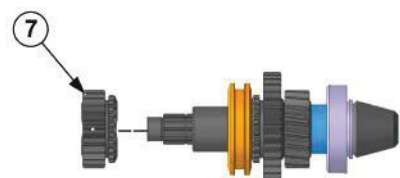

ITL000536

15. DISASSEMBLY OF TAIL PINION SHAFT

Step 8:

1. Remove the shifter sleeve (8).

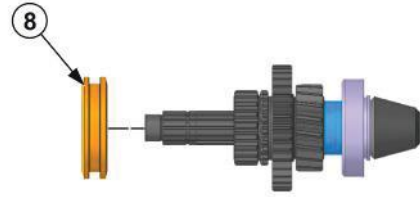

ITL000537

Step 9:

1. Remove the hub (9).

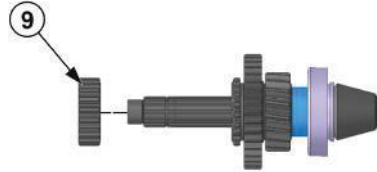

ITL000538

Step 10:

1. Remove the dog gear low Z-35 (10).



ITL000539

Step 11:

1. Remove the driver gear 4WD (11).



ITL000540

Step 12:

1. Remove the spacer (12).



ITL000541

Step 13:

1. Remove the taper roller bearing (13).



ITL000542

16. DISASSEMBLY OF RANGE LAY SHAFT

Disassembly of Range Lay Shaft

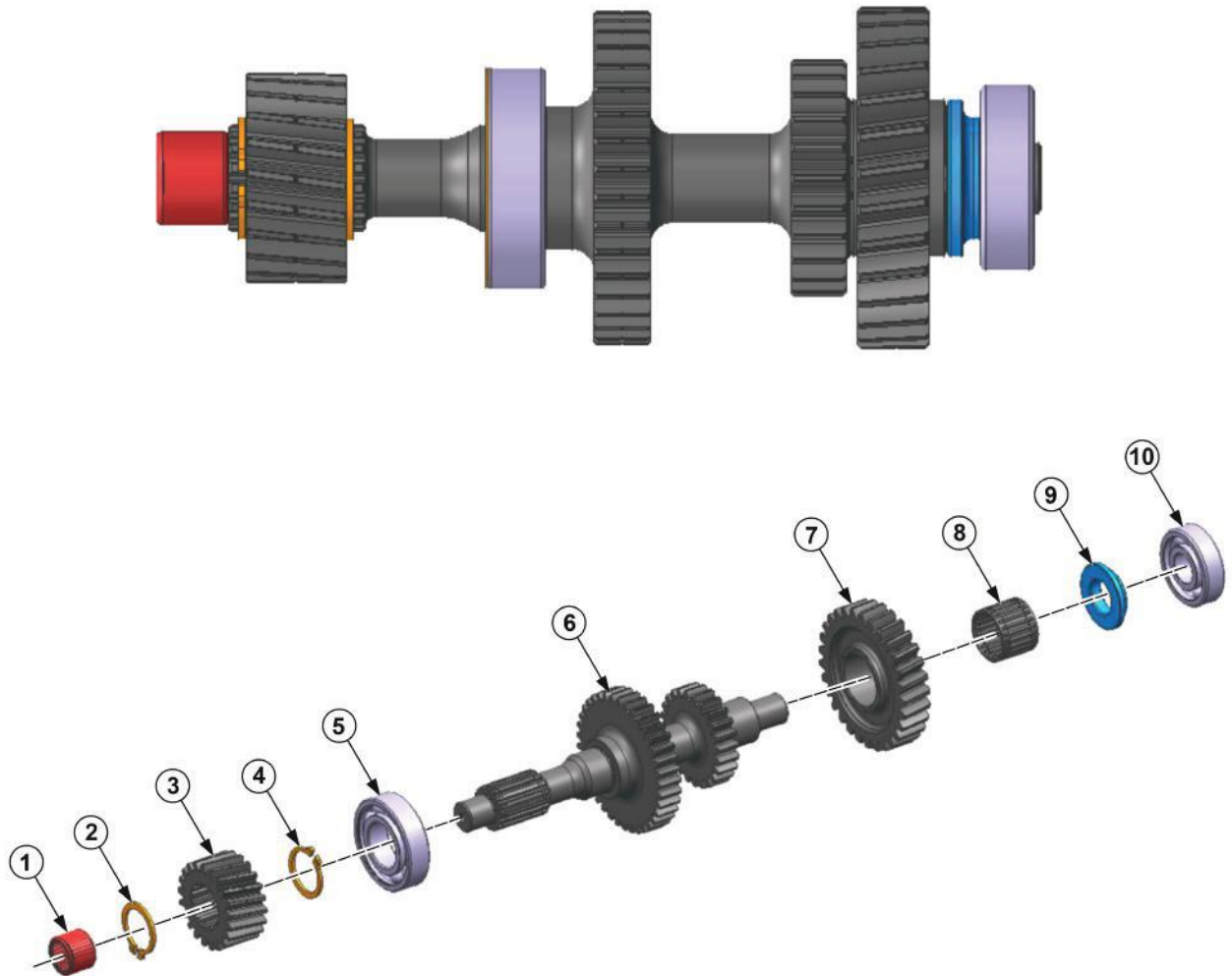

ITL000543

1 — Needle Bush

2 — Circlip

3 — Driven Gear Z-21

4 — Circlip

5 — Ball Bearing 6206

6 — Range Lay Shaft

7 — Idler Gear 4WD

8 — Needle Roller Bearing

9 — Spacer

10 — Ball Bearing 6304

16. DISASSEMBLY OF RANGE LAY SHAFT

Step 1 :

1. Remove the needle bush (1).

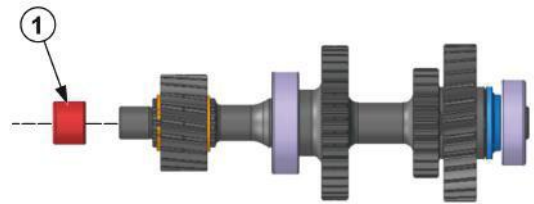

ITL000544

Step 2:

1. Remove the circlip (2).

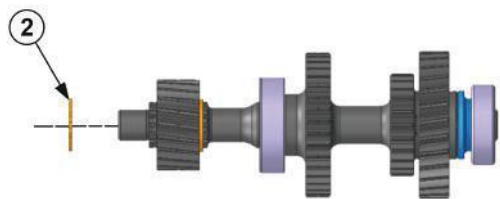

ITL000545

Step 3:

1. Remove the driven gear Z-21 (3).



ITL000546

Step 4:

1. Remove the circlip (4).

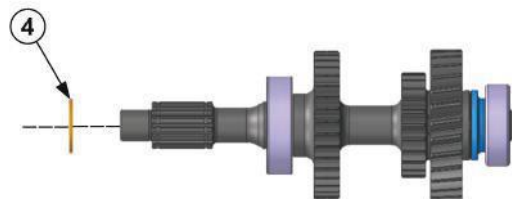

ITL000547

Step 5:

1. Remove the ball bearing 6206 (5).



ITL000548

16. DISASSEMBLY OF RANGE LAY SHAFT

Step 6:

1. Remove the ball bearing 6304 (6).



ITL000549

Step 7:

1. Remove the spacer (7).



ITL000550

Step 8:

1. Remove the idler gear 4WD (8).



ITL000551

Step 9:

1. Remove the needle roller bearing (9).

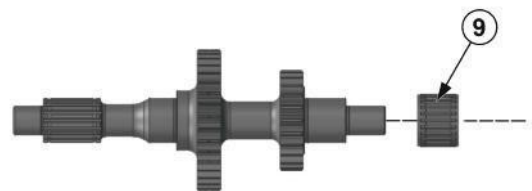

ITL000552

17. DISASSEMBLY OF PTO SUB ASSEMBLY

Disassembly of PTO Sub Assembly



ITL000553

1 — Circlip

2 — Ball Bearing

3 — Connecting Sleeve PTO

4 — Circlip

5 — Ball Bearing 6205

6 — PTO Intermediate Shaft

7 — Spacer

8 — Ball Bearing 6206

9 — Ball Bearing 6205

10 — Hub PTO

11 — Sliding Gear PTO Z-43

12 — Fixed Gear Z-60

13 — Needle Roller Bearing

14 — PTO Output Shaft

15 — Ball Bearing 6207

18. DISASSEMBLY DIFFERENTIAL CAGE SUB

Dis-assembly Differential Cage Sub

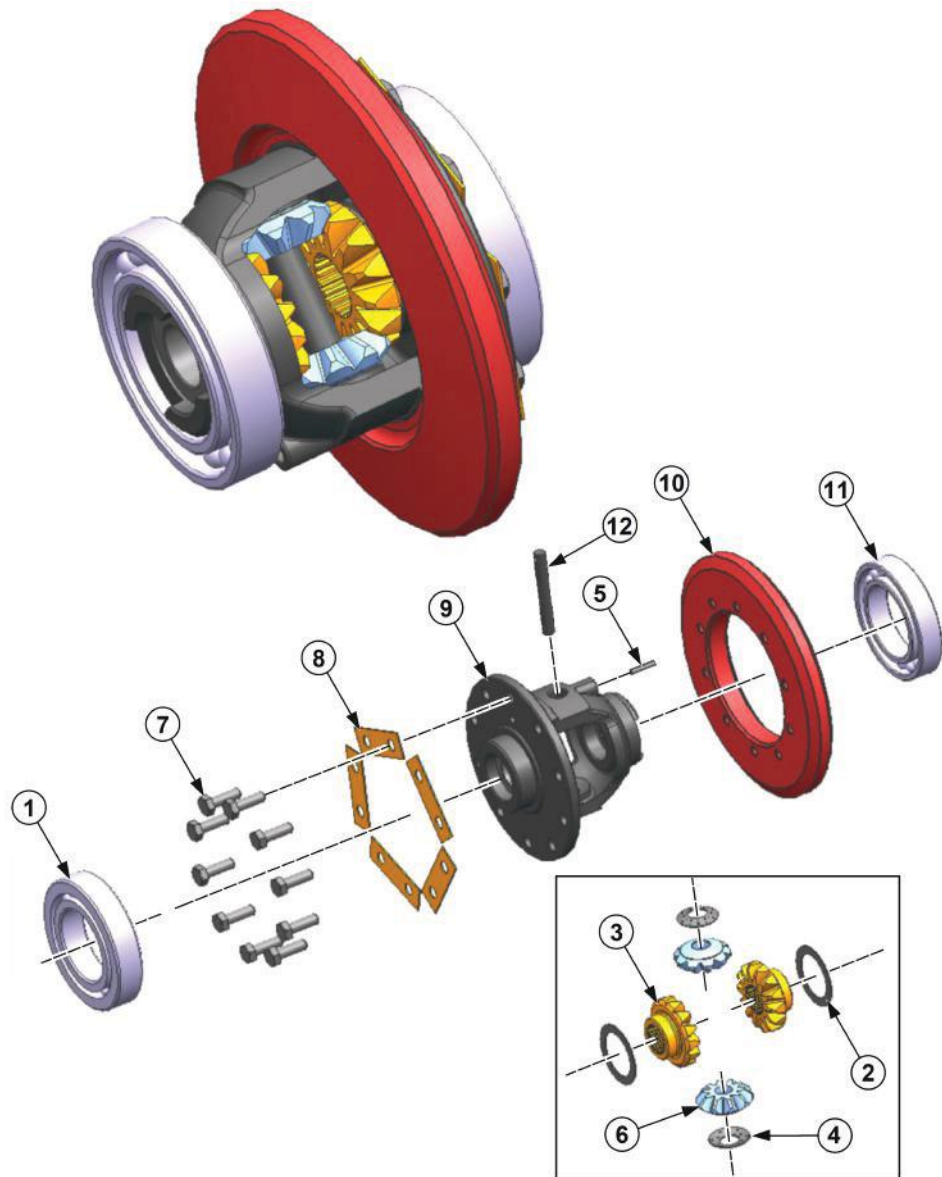

ITL000554

1 — Ball Bearing 6011

2 — Diff Side Gear Liner

3 — Diff. Side Gear 14T

4 — Thrust Washer

5 — Spring Cotter Sleeve

6 — Diff Pinion Gear 10T

7 — Bolt

8 — Locking Washer

9 — Diff Cage Assembly

10 — Crown Wheel

11 — Ball Bearing 6211

12 — Pinion shaft

18. DISASSEMBLY DIFFERENTIAL CAGE SUB

Step 1:

1. Remove the differential cage ball bearing 6011 (1).

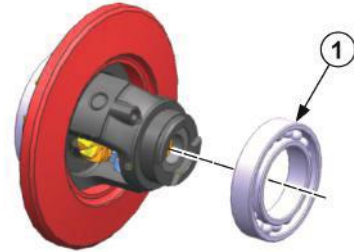

ITL000555

Step 2:

1. Remove the differential cage ball bearing 6211 (2).

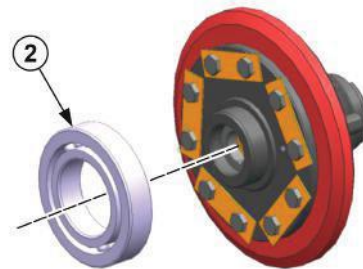

ITL000556

Step 3:

1. Remove the spring cotter sleeve (3) using the tool.

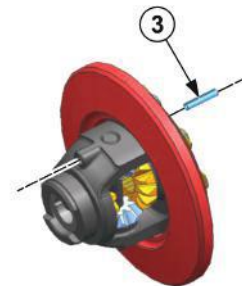

ITL000557

Step 4:

1. Remove the pinion shaft (4).



ITL000558

Step 5:

1. Remove the differential pinion gear (5).

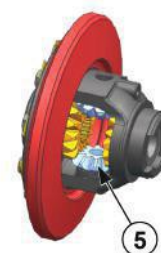

ITL000559

18. DISASSEMBLY DIFFERENTIAL CAGE SUB

Step 6:

1. Remove the all differential side gear, thrust washer and liner.



ITL000561

Step 7:

1. Remove the bolt (6) and locking washer (7).

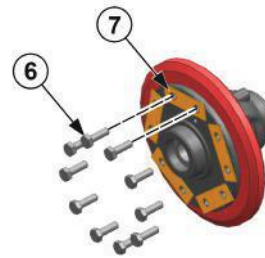

ITL000560

Step 8:

1. Remove the crown wheel (9).

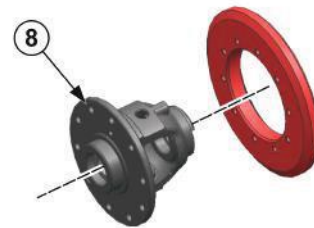

ITL000562

19. ASSEMBLY OF DIFFERENTIAL CAGE SUB

Assembly of Differential Cage Sub

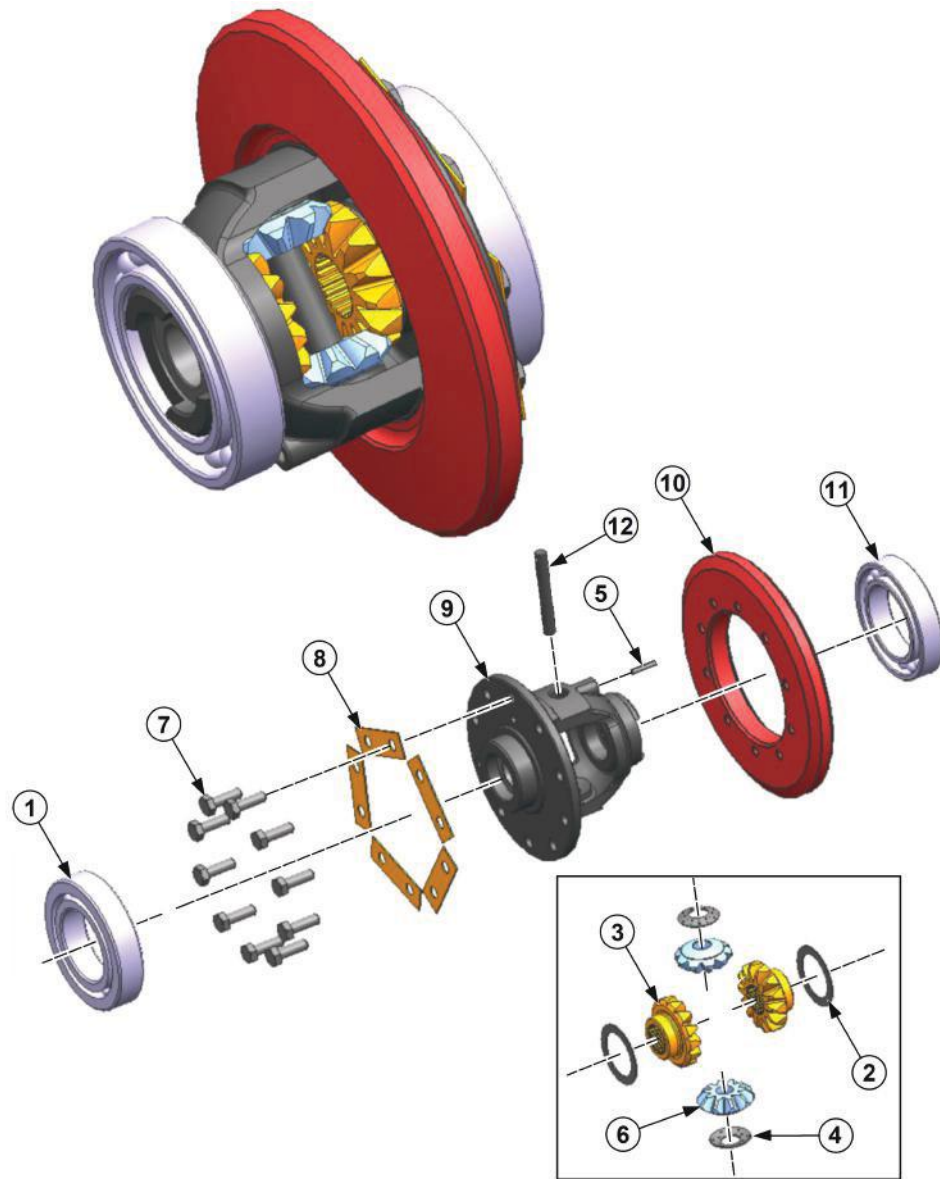

ITL000554

1 — Ball Bearing 6011

2 — Diff. Side Gear Liner

3 — Diff. Side Gear 14T

4 — Thrust Washer

5 — Spring Cotter Sleeve

6 — Diff. Pinion Gear 10T

7 — Bolt

8 — Locking Washer

9 — Diff Cage Assembly

10 — Crown Wheel

11 — Ball Bearing 6211

12 — Pinion shaft

19. ASSEMBLY OF DIFFERENTIAL CAGE SUB

Step 1:

1. Take the differential cage (1).
2. Assemble the crown wheel (2) in RHS of differential cage (1). Plain face of the crown wheel towards the cage side.

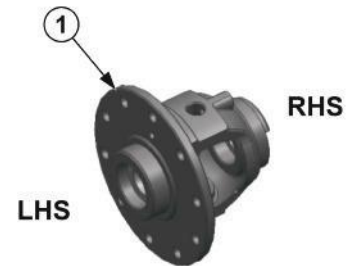

ITL000564

Step 2:

1. Tight the bolts (3) of diff. cage and lock the locking strip (4).
- Torque= 13.28-16.96 lbf.ft (18-23 Nm)
 - Loctite 243

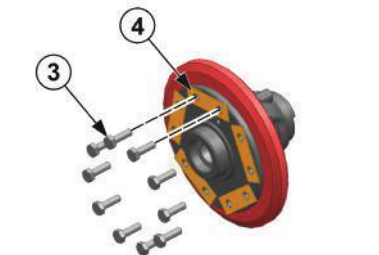

ITL000565

Step 3:

1. Press the LHS ball bearing 6211 on the differential cage by using mandrel.

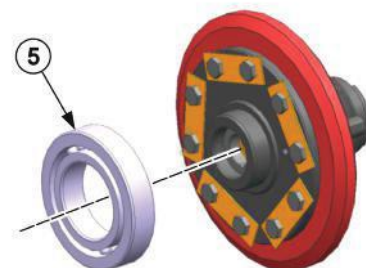

ITL000566

Step 4:

1. Assembly differential side gear.



ITL000567

19. ASSEMBLY OF DIFFERENTIAL CAGE SUB

Step 5:

1. Assemble the inner and outer gear with liner.
2. Assemble the second differential pinion gear with thrust washer.



ITL000568

Step 6:

1. Insert the pinion shaft (6).



ITL000569

Step 7:

1. Align the hole (A) of shaft with hole (B) end. Press the sleeve by using hammer.



ITL000571

Step 8:

1. Assemble ball bearing 6011 (7) on the RHS differential cage by using mandrel.

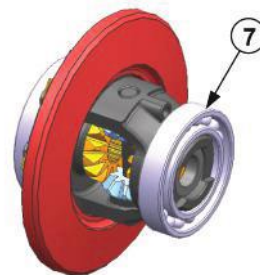

ITL000570

20. ASSEMBLY TAIL PINION SHAFT

Assembly of Tail Pinion Shaft

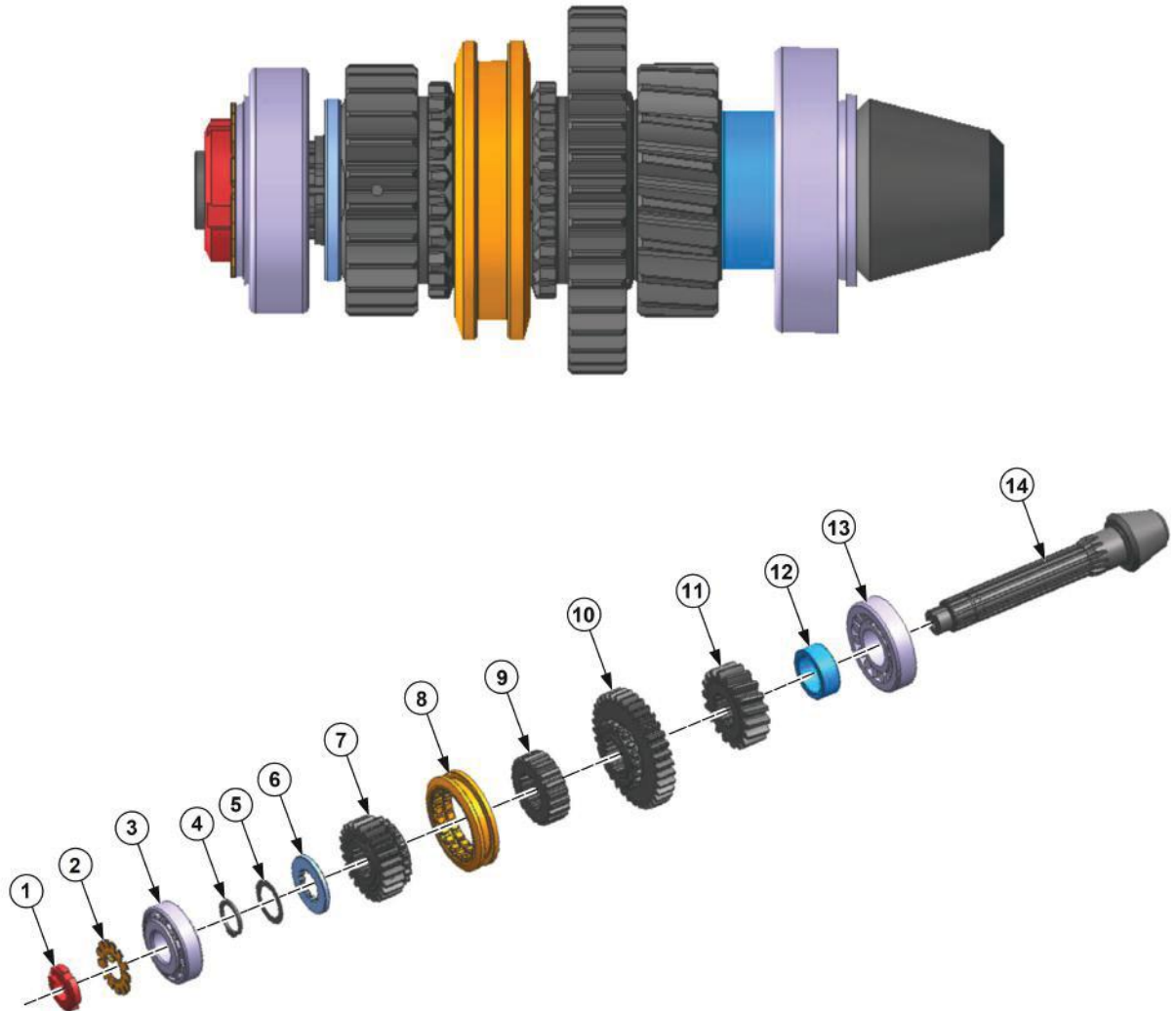

ITL000529

1 — Withdrawal Nut

2 — Locking Washer

3 — Taper Roller Bearing

4 — External Circlip

5 — Shim

6 — Thrust Washer

7 — Dog Gear High Z-24

8 — Shifter Sleeve

9 — Hub

10 — Dog Gear Low Z-35

11 — Driver Gear 4WD

12 — Spacer

13 — Taper Roller Bearing

14 — Tail Pinion Shaft

20. ASSEMBLY TAIL PINION SHAFT

Step 1 :

1. Take tail pinion shaft (1) and taper roller bearing (2).
2. Install the taper roller bearing (2) by using mandrel tool 9+9 001 (3).

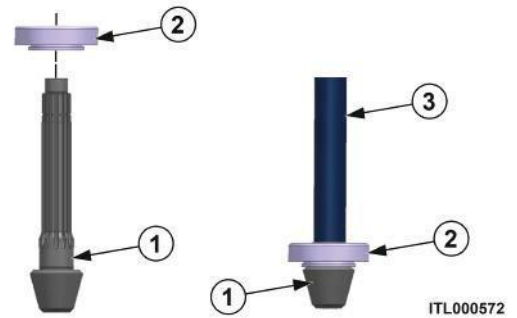

Step 2:

1. Insert the spacer (4).
2. Insert the driver gear 4WD (5).

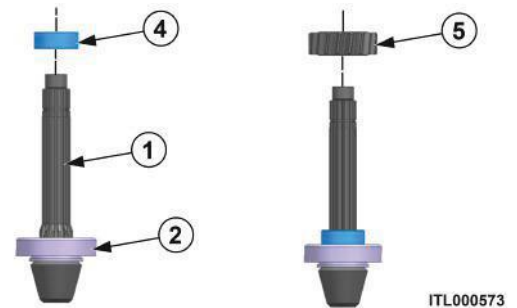

Step 3:

1. Insert the dog gear low (6).
2. Insert the hub (7).

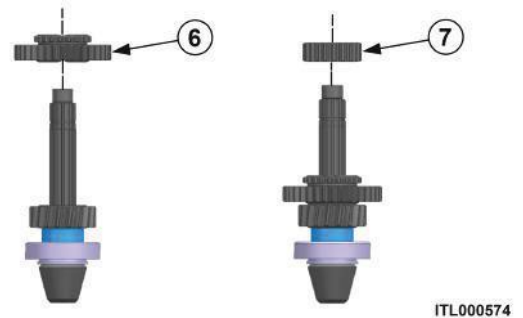

Step 4:

1. Insert the shifter sleeve (8).
2. Insert the dog gear high (9).

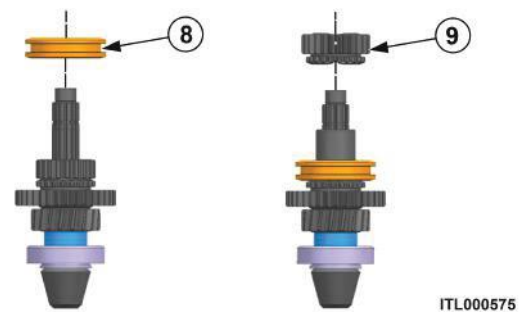

Step 5:

1. Insert the thrust washer (10).
2. Insert the circlip (11).

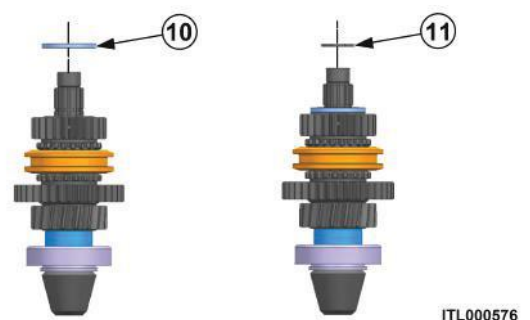

20. ASSEMBLY TAIL PINION SHAFT

Procedure of Shim Selection for Tail Pinion Shaft

Step 1 :

1. Assemble the circlip and lock the tail pinion shaft.

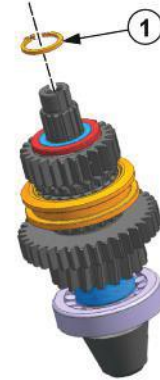

ITL000577

Step 2:

1. Measure the clearance between spacer and dog gear low.

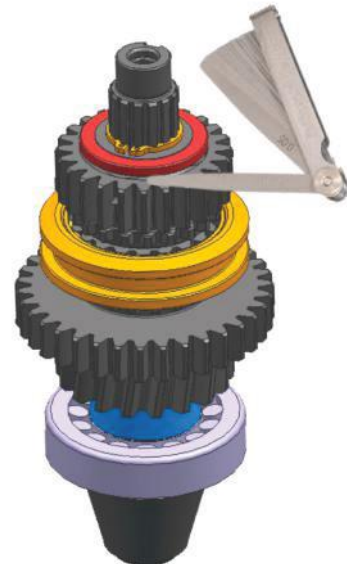

ITL000578

Step 3:

1. Remove the circlip. Insert the shims as per required. Reassemble the circlip at its position.

Shim selection process :-

Example :

Clearance between spacer and dog gear low = 0.25 mm (A)

Specified limit = 0.10 - 0.15 mm (B)

Required shim thickness = A - B

= 0.25 - 0.10

= 0.15 mm



ITL000579

21. ASSEMBLY OF RANGE LAY SHAFT

Assembly of Range Lay Shaft

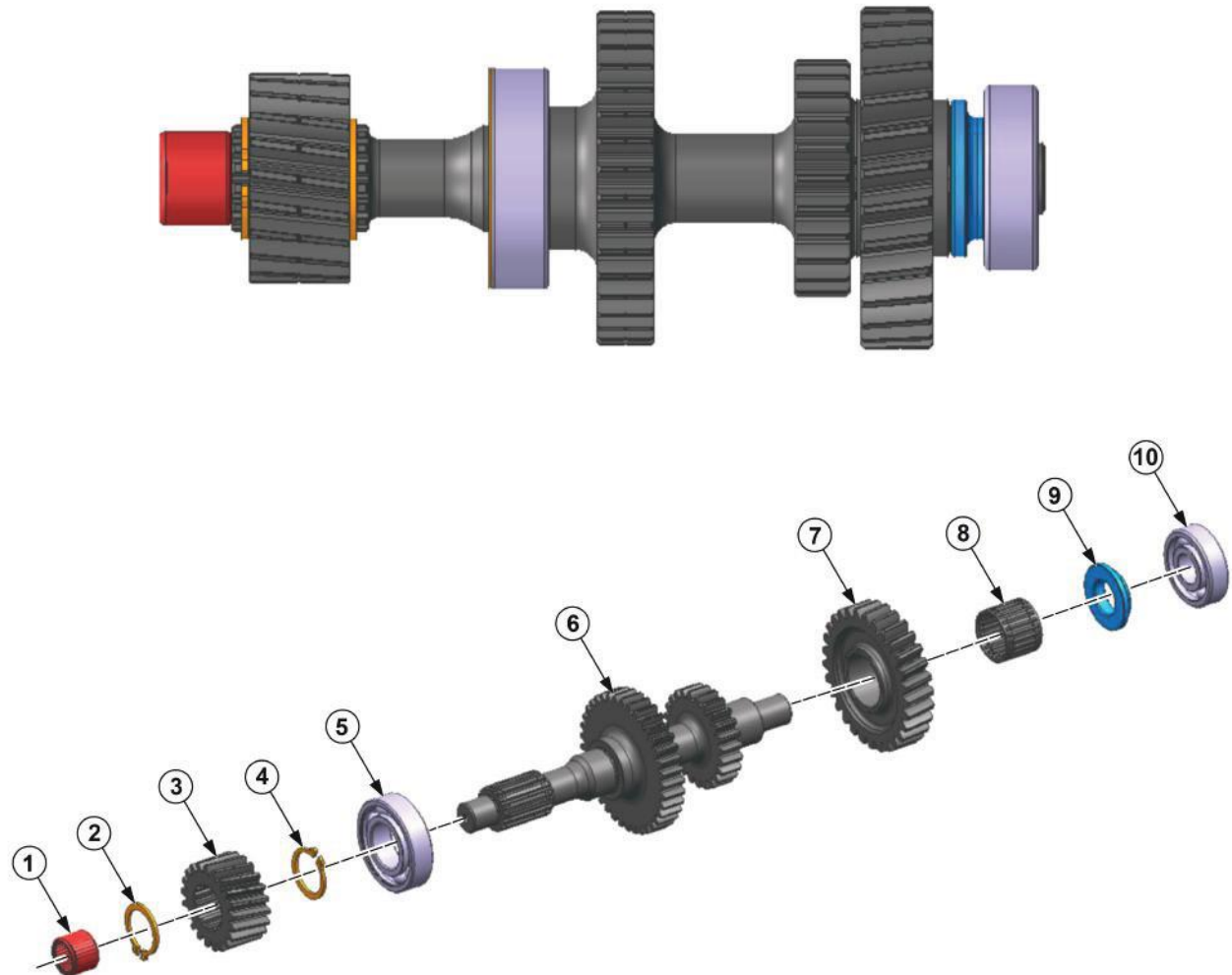

ITL000543

- 1 — Needle Bush
- 2 — Circlip
- 3 — Driven Gear Z-21
- 4 — Circlip
- 5 — Ball Bearing 6206

- 6 — Range Lay Shaft
- 7 — Idler Gear 4WD
- 8 — Needle Roller Bearing
- 9 — Spacer
- 10 — Ball Bearing 6304

21. ASSEMBLY OF RANGE LAY SHAFT

Step 1:

1. Insert the needle roller bearing (1).

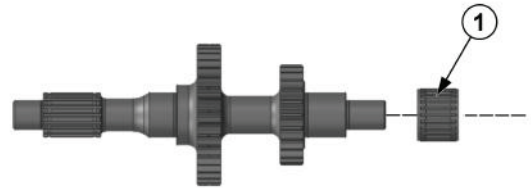

ITL000580

Step 2:

1. Insert the idle gear 4WD (2).



ITL000581

Step 3:

1. Insert the spacer (3).



ITL000582

Step 4:

1. Insert the ball bearing 6304 (4).



ITL000583

Step 5:

1. Insert the ball bearing 6206 (5).



ITL000584

21. ASSEMBLY OF RANGE LAY SHAFT

Step 6:

1. Insert the circlip (6).

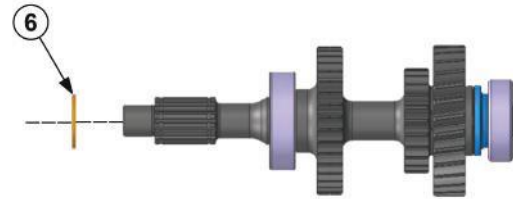

ITL000585

Step 7:

1. Insert the driven gear Z-21 (7).

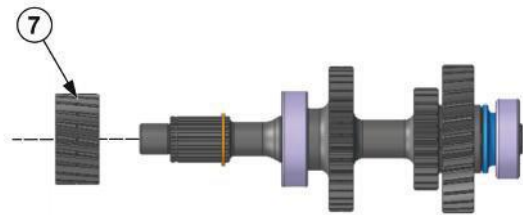

ITL000586

Step 8:

1. Insert the circlip (8).

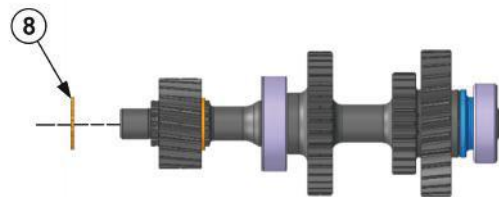

ITL000587

Step 9:

1. Insert the needle bush (9).

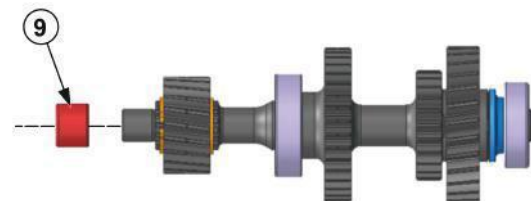

ITL000588

22. ASSEMBLY OF PTO SUB

Assembly of PTO Sub

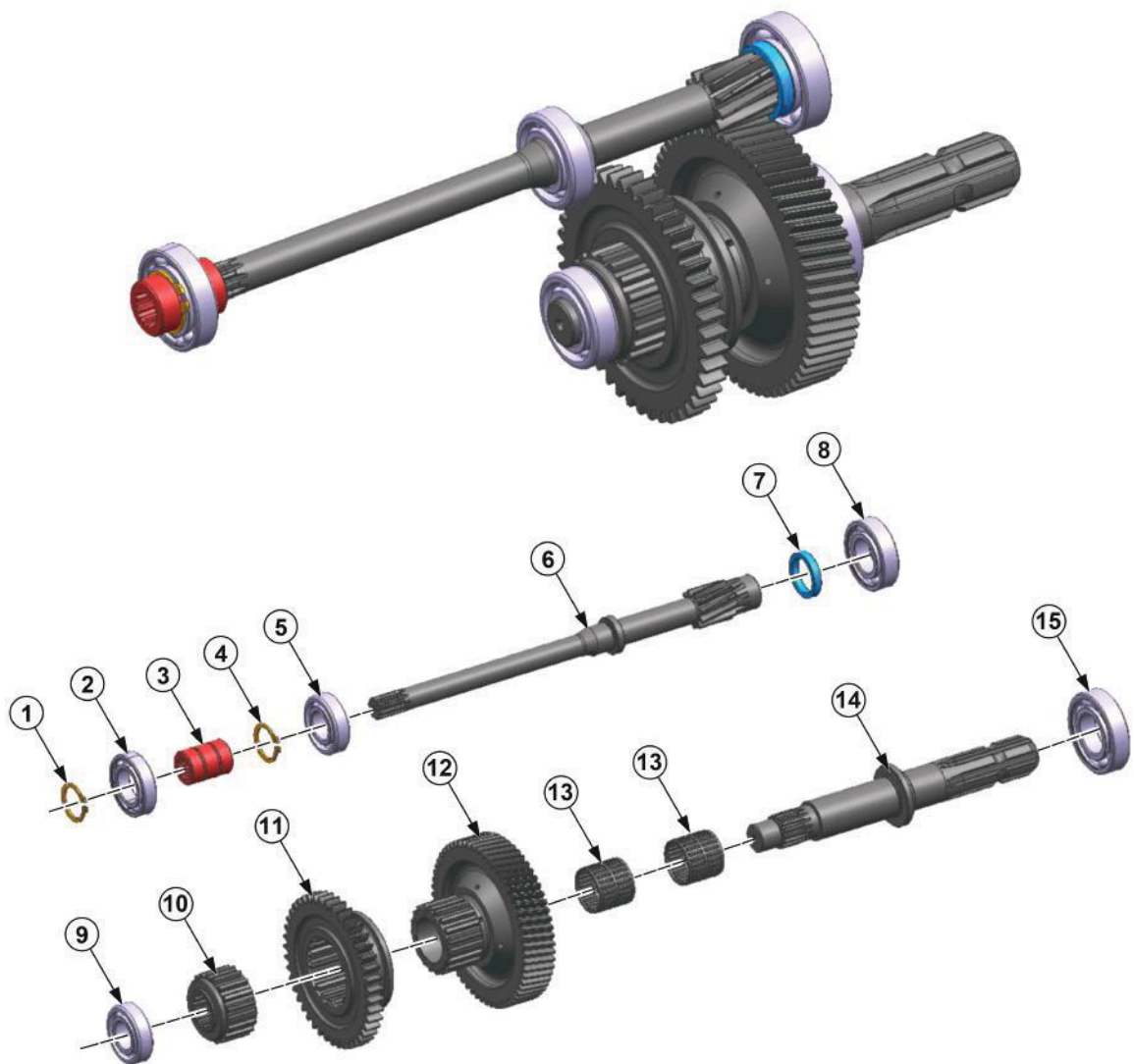

ITL000553

1 — Circlip

2 — Ball Bearing

3 — Connecting Sleeve PTO

4 — Circlip

5 — Ball Bearing 6205

6 — PTO Intermediate Shaft

7 — Spacer

8 — Ball Bearing 6206

9 — Ball Bearing 6205

10 — Hub PTO

11 — Sliding Gear PTO Z-43

12 — Fixed Gear Z-60

13 — Needle Roller Bearing

14 — PTO Output Shaft

15 — Ball Bearing 6207

22. ASSEMBLY OF PTO SUB

Step 1 :

1. Pick ball bearing 6207 (1) and press it on rear pto output shaft (1) from outer side by using mandral 18ME-244 special tool, as shown in figure.

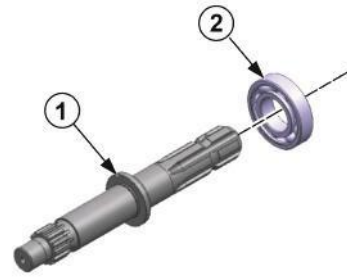

ITL000589

Step 2:

1. Pick ball bearing 6205 (1) and press fit it in transmission housing at position, as shown in figure.

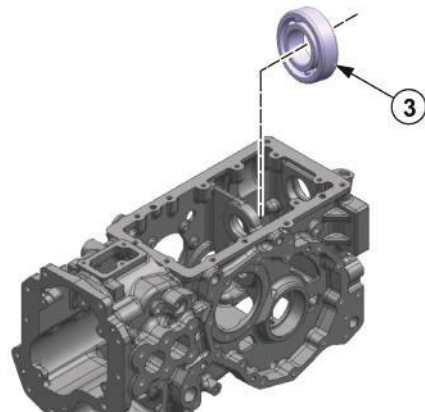

ITL000592

Step 3:

1. Pick fixed gear PTO Z-59 (6) & sliding gear PTO Z-43 (4) and assembled them. Insert needle roller bearing (5) 2 nos between assembled fixed gear PTO Z-59 (5) & sliding gear PTO Z-43 (4) as shown in figure.

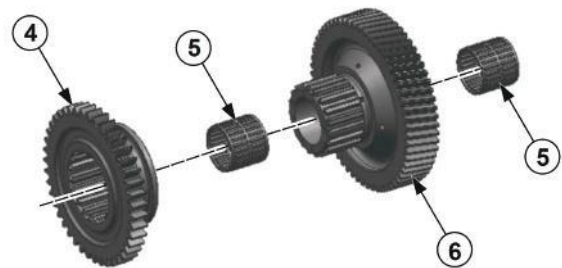

ITL000590

Step 4:

1. Insert fixed gear PTO Z-59 (6), sliding gear PTO Z-43 (4) & needle roller bearing (5) 2 nos in PTO output shaft

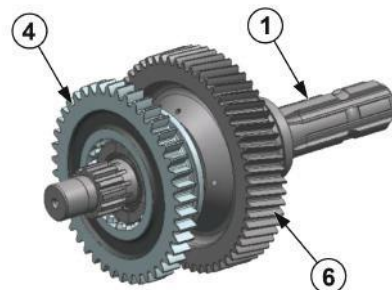

ITL000591

Step 5:

1. Insert hub PTO (7) in PTO output shaft.

23. ASSEMBLY OF TRUMPET HOUSING

Assembly of Trumpet Housing

Step 1 :

1. Assemble ball bearing 6406 (2) in trumpet housing (1). Lock the external circlip by using mandrel 18ME248 and insert spacer (3), bull pinion shaft (4).

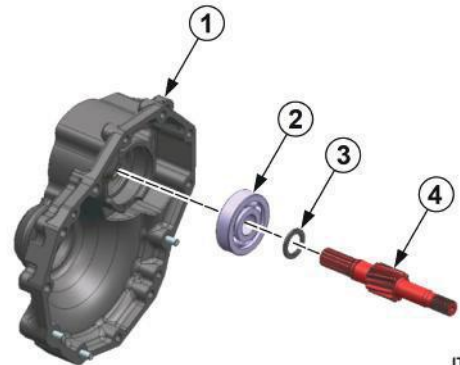

ITL000593

Step 2:

1. Lock the external circlip (5) by using tool.

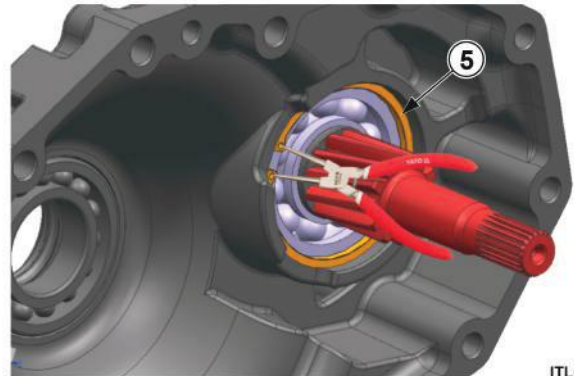

ITL000594

Step 3:

1. Lock the internal circlip (6).

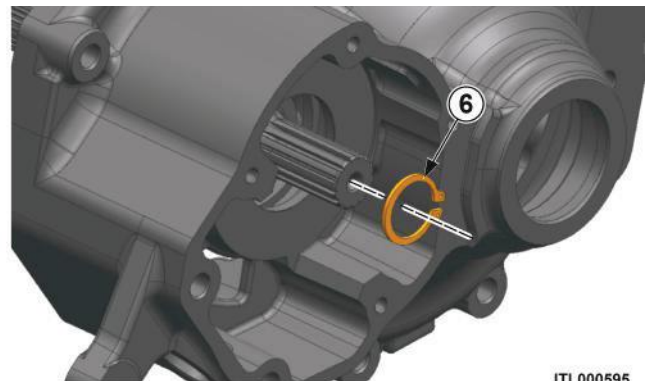

ITL000595

Step 4:

1. Assemble the brake actuating shaft (7).

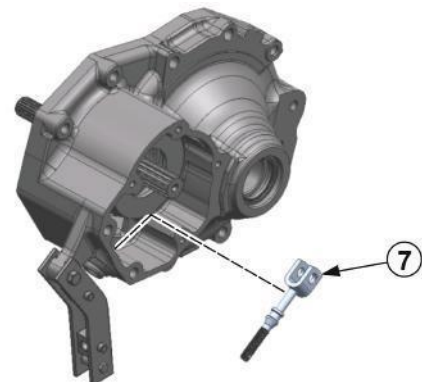

ITL000596

23. ASSEMBLY OF TRUMPET HOUSING

Step 5:

1. Insert the brake assembly (8).

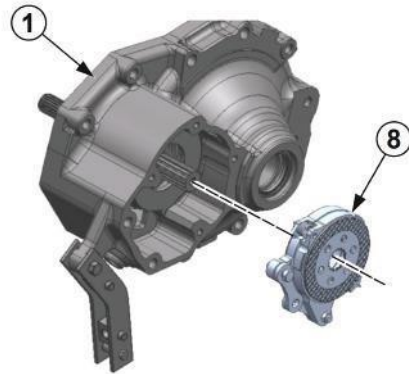

ITL000597

Step 6:

1. Insert the bolt (9) in brake assemble and engage with brake actuating shaft.

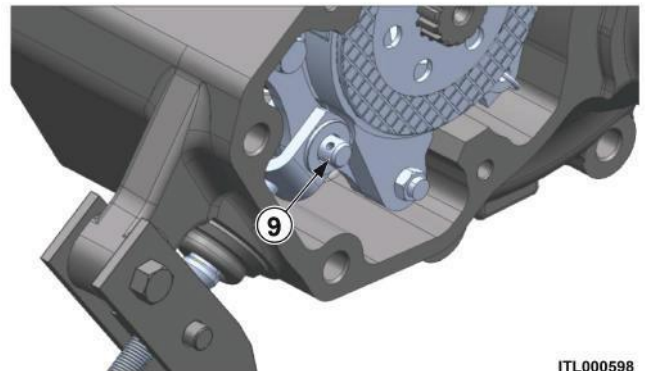

ITL000598

Step 7:

1. Insert the cotter pin (10).

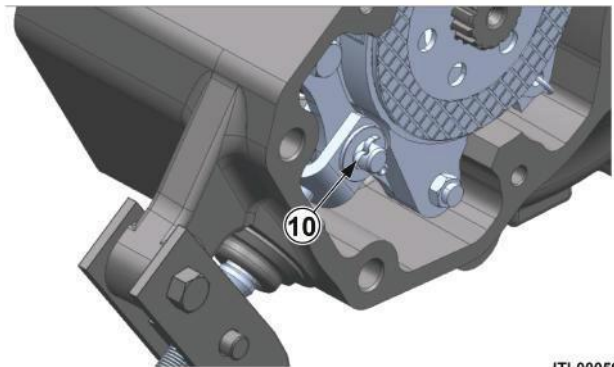

ITL000599

Step 8:

1. Apply sealant 5811 (11) on the brake cover.

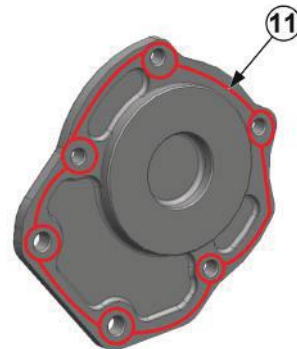

ITL000600

23. ASSEMBLY OF TRUMPET HOUSING

Step 9:

1. Apply loctite 243 on the bolts (13) and insert both bolts (13) & washer (14) with brake cover (12) in trumpet housing (1). Tight the bolts of brake cover.
2. Apply Torque as per specification and assemble the brake cover (12)..

| |
|-------------------------------------------------------|
| Torque |
| Specification — 13.28-18.44 lbf.ft (18-25 Nm). |

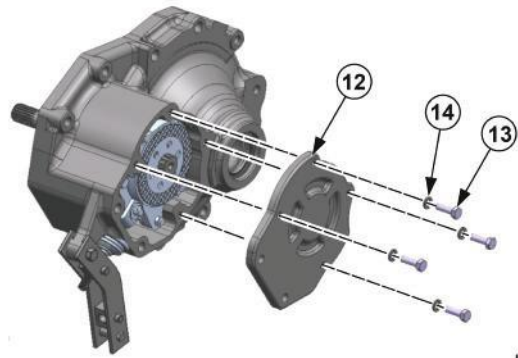

ITL000601

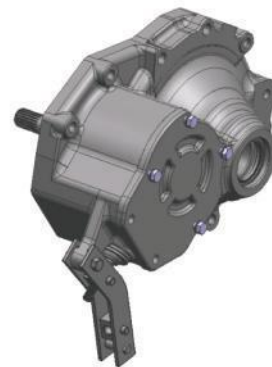

ITL000602

Step 10:

1. Assemble the oil seal (15) in brake housing by using mandrel 18ME252.

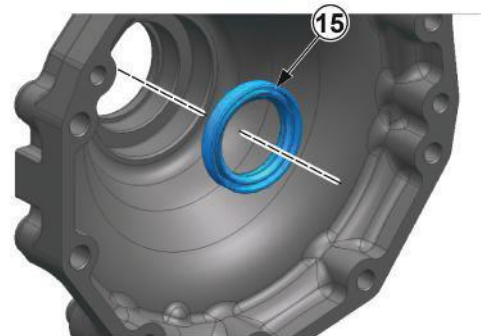

ITL000603

Step 11:

1. Assemble the ball bearing 6209 (16) in brake housing.

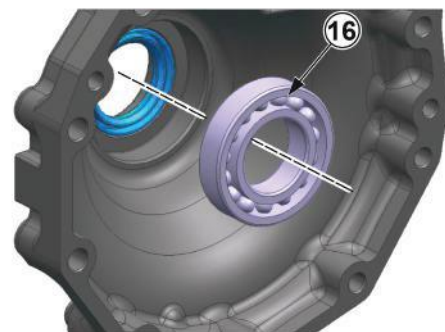

ITL000604

23. ASSEMBLY OF TRUMPET HOUSING

Step 12:

1. Assemble the rear axle (17).

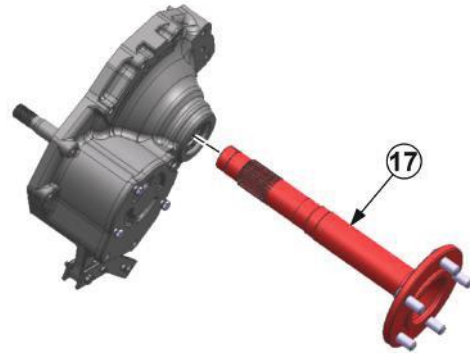

ITL000605

Step 13:

1. Insert the spacer (18), bull gear (19) and assemble ball bearing 6308 (20) by using mandrel HST 07 . Insert spacer, lock washer.

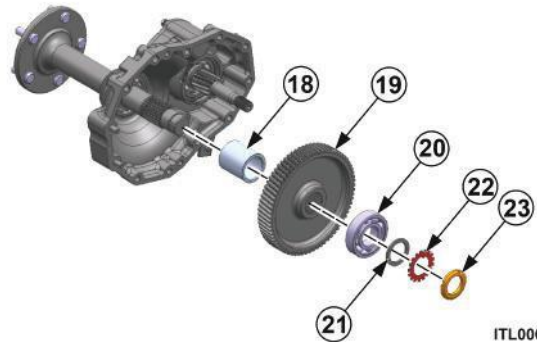

ITL000606

1. Tight the locking nut (23) by using tool 18ME235. Apply torque as per specification.

| |
|--------------------------------------------------------|
| Torque |
| Specification — 44.25 - 51.63 lbf.ft (60-70 NM) |



ITL000607

24. ASSEMBLY OF DROP BOX MID PTO

Assembly of Drop Box Mid PTO

Step 1 :

1. Insert the ball Bearing 6204 (2) in drop box mid pto (1).

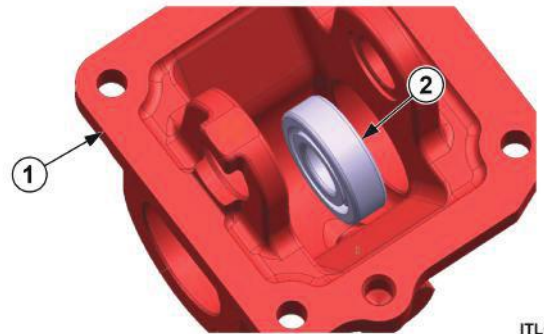

ITL000608

Step 2:

1. Assemble the mid PTO output shaft (3) and ball bearing 6005 (4). Insert the assembly in drop box mid pto (1) as shown in the figure.

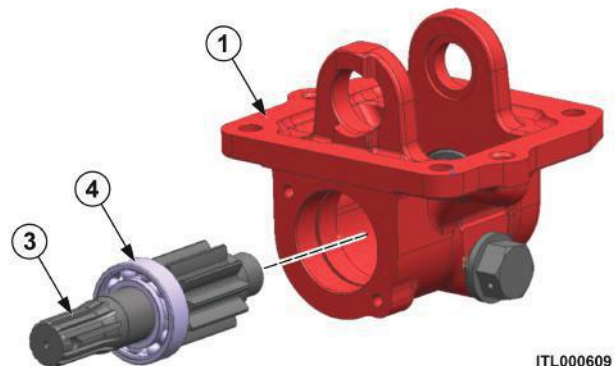

ITL000609

Step 3:

1. Insert the shim (5).

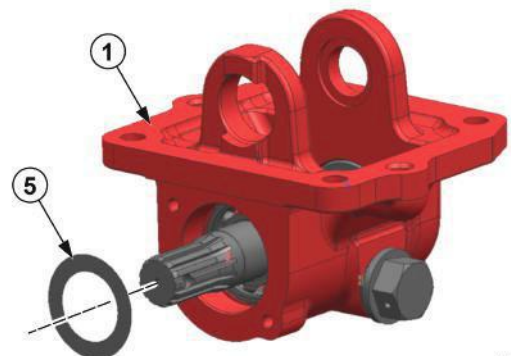

ITL000610

Step 4:

1. Insert the internal circlip (6).

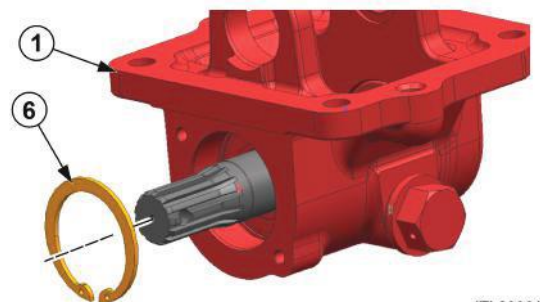

ITL000611

24. ASSEMBLY OF DROP BOX MID PTO

Step 5:

1. Insert the oil seal (7).

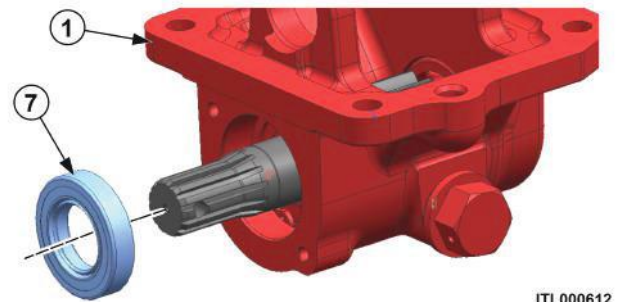

ITL000612

Step 6:

1. Insert the oil seal stopper (9) and tighten the bolt (8). Apply torque as per specification.

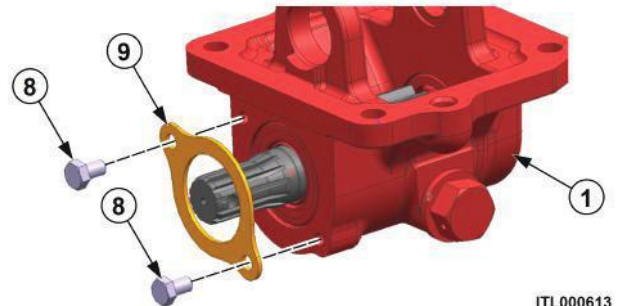

ITL000613

| Specification |
|-----------------------------------------|
| Torque — 3.69 - 7.38 lbf.ft (5 - 10 Nm) |

Step 7:

1. Assemble ball bearings (10), idler gear mid PTO (12), circlip (11), spacer (13) and shim (14). Insert the assembly in drop box mid pto (1) as shown in the figure.

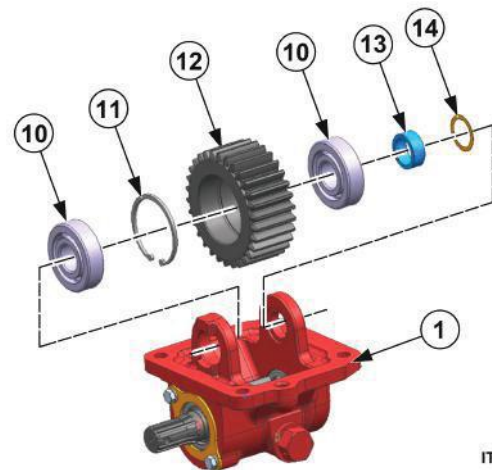

ITL000614

Step 8:

1. Insert the idler gear mid PTO assembly (15) in drop box mid pto.

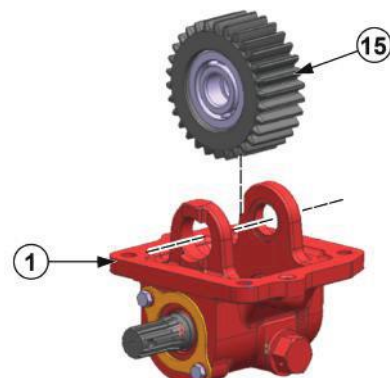

ITL000615

24. ASSEMBLY OF DROP BOX MID PTO

Step 9:

1. Insert the idler shaft mid PTO (16).

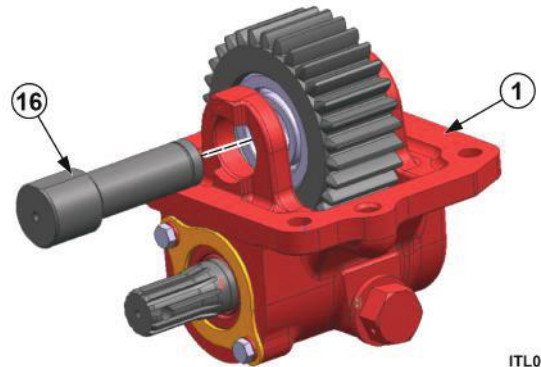

ITL000616

Step 10:

1. Insert the external circlip (17) as shown in the figure.

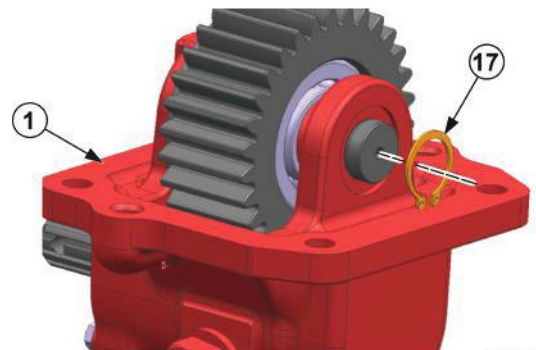

ITL000617

Step 11:

1. Assemble the bolts (18) of drop box mid PTO assembly (1). Apply the torque as per specification.

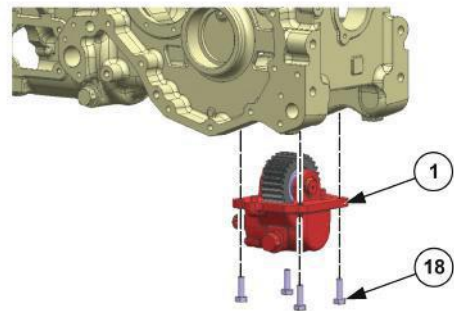

ITL000619

| Specification |
|--------------------------------------------|
| Torque — 22.13 - 29.50 lbf.ft (30 - 40 Nm) |

25. ASSEMBLY OF DIFFERENTIAL HOUSING

Assembly of Differential Housing

Step 1 :

1. Insert ball bearings 6205 (1) in differential housing.

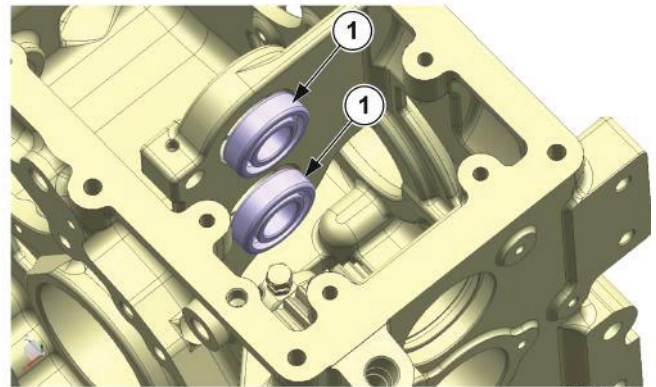

ITL000620

Step 2 :

1. Insert the spacer (2) , PTO sliding gear (3), hub (4), needle roller bearings (5) and PTO fixed gear (6).

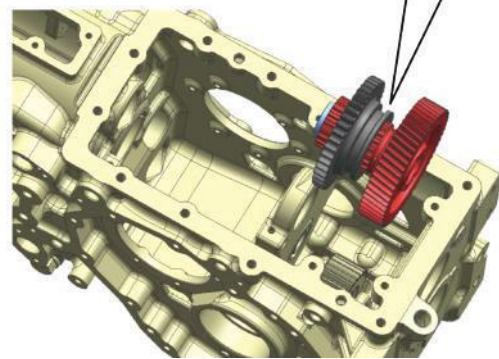
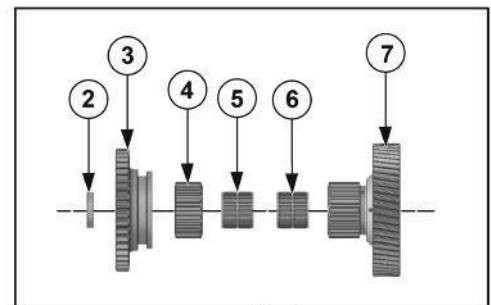

ITL000621

Step 3:

1. Pick the ball bearing 6207 (8) and press fit in PTO output shaft (9) as shown in figure. Insert the PTO output shaft and bearing assembly into differential housing.

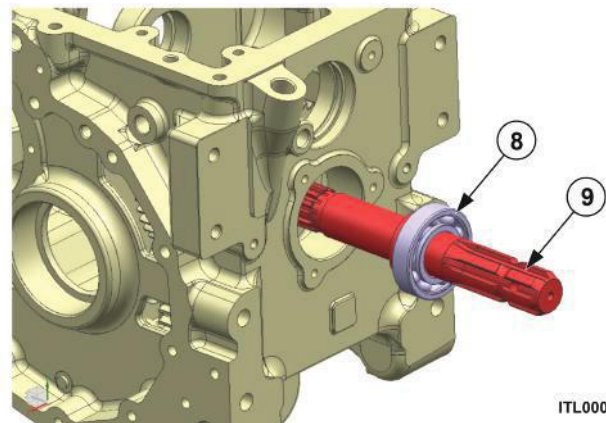

ITL000622

25. ASSEMBLY OF DIFFERENTIAL HOUSING

Step 4:

1. Insert the shim (10).

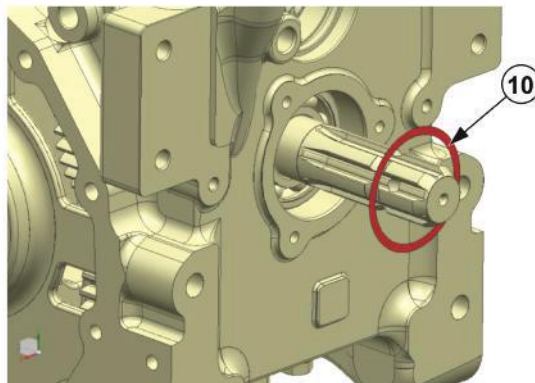

ITL000623

Step 5:

1. Assemble the oil seal (11) and PTO output cover (12). Tight the bolts (13) as per specification.
2. Apply Loctite 5188.

| Specifications |
|--------------------------------------------|
| Torque — 13.28 - 16.96 lbf.ft (18 - 23 Nm) |

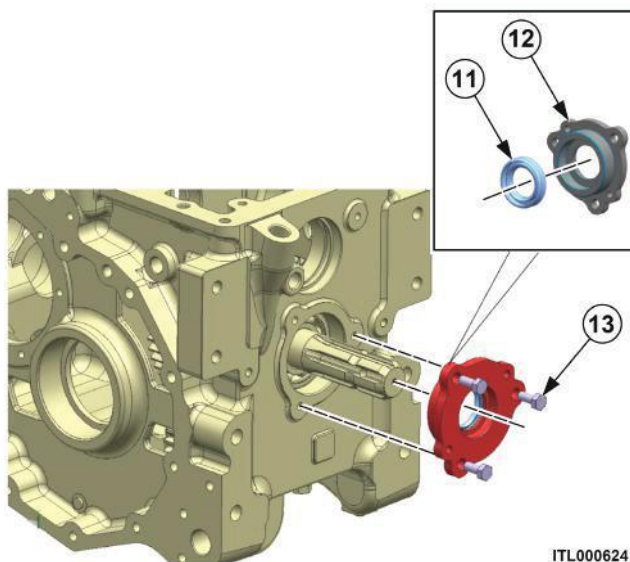

ITL000624

Step 6:

1. Insert the PTO cap (14).

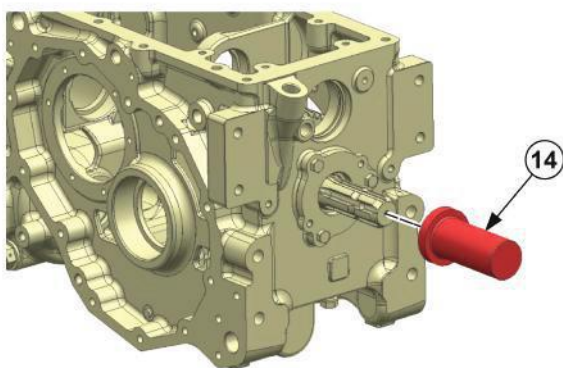

ITL000625

25. ASSEMBLY OF DIFFERENTIAL HOUSING

Step 7:

1. Insert the PTO fork (15).

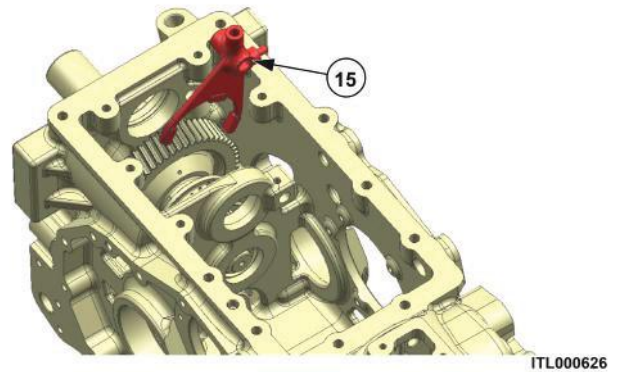

Step 8:

1. Assemble the link PTO shifter (16) and pivot lug (17).

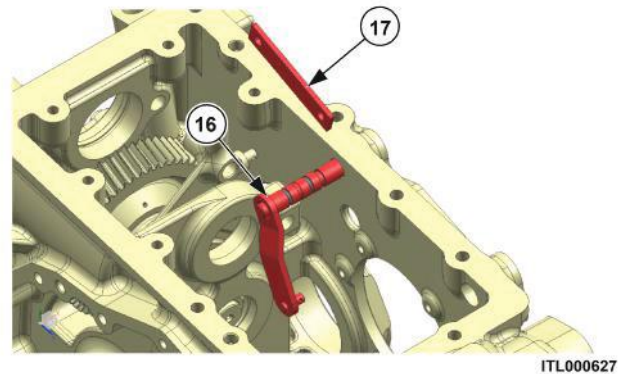

Step 9:

1. Assemble the cotter pin (18).

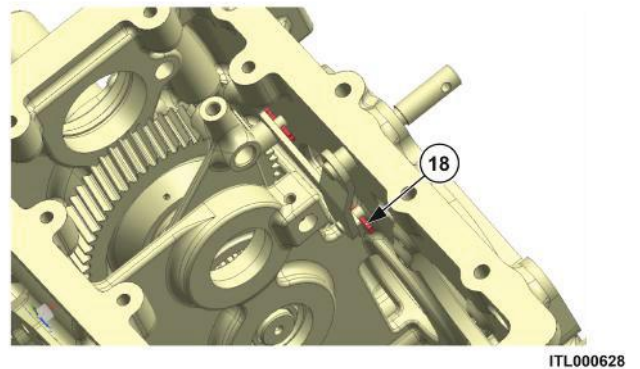

Step 10:

1. Insert the PTO shifter rod (20).
2. Assemble the cap (19) and circlip (21)

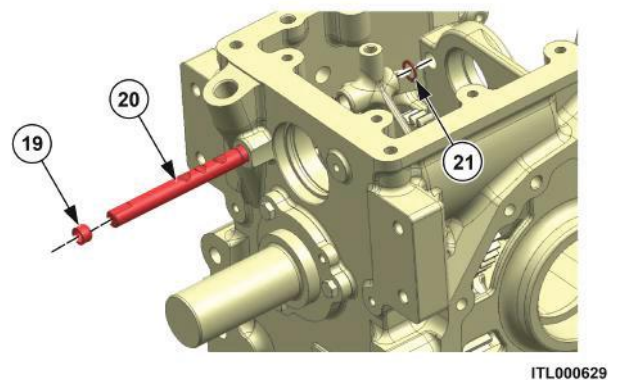

25. ASSEMBLY OF DIFFERENTIAL HOUSING

Step 11:

1. Assemble the split pin (22).

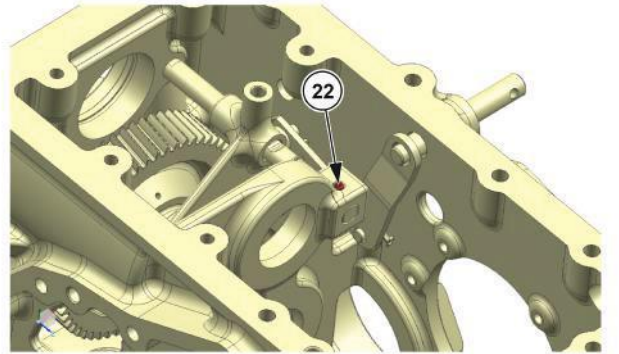

ITL000630

Step 12:

1. Insert the ball (26) and spring (25).
2. Tight the bolt (23) and nut (24).

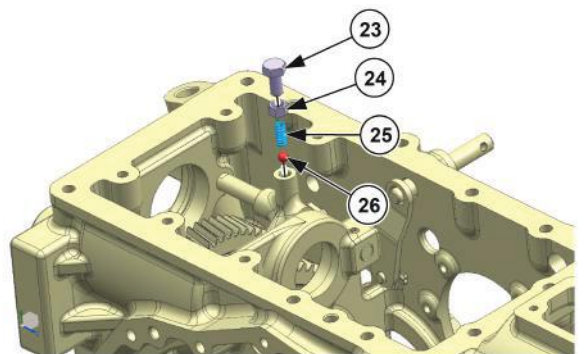

ITL000631

Step 13:

1. Assemble the locking plate (27).
2. Apply loctite 5188 and tighten the bolt (29) with washer (28) as per torque specification.

| Specification |
|-----------------------------------------|
| Torque :- 13.28-16.96 lbf.ft (18-23 Nm) |

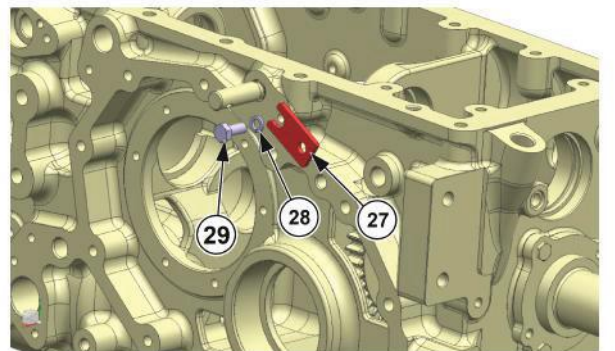

ITL000632

Step 14:

1. Assemble the ball bearing (30) and spacer (31). Insert the assembly into differential housing as shown in the figure.

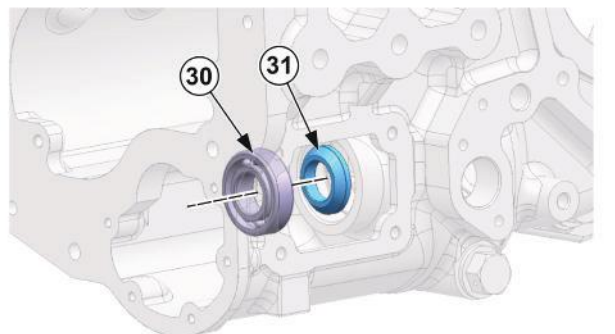

ITL000633

25. ASSEMBLY OF DIFFERENTIAL HOUSING

Step 15:

1. Insert the internal circlip (32) in differential housing as shown in the figure.

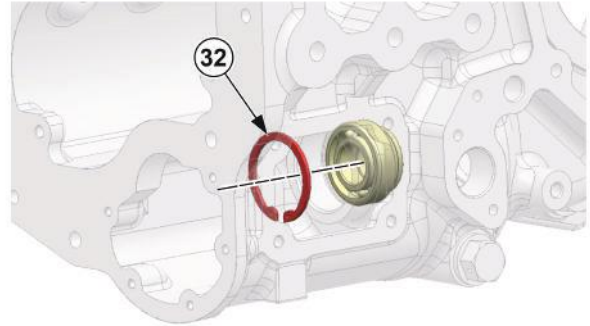

ITL000634

Step 16:

1. Insert the oil seal (33) as shown in the figure.

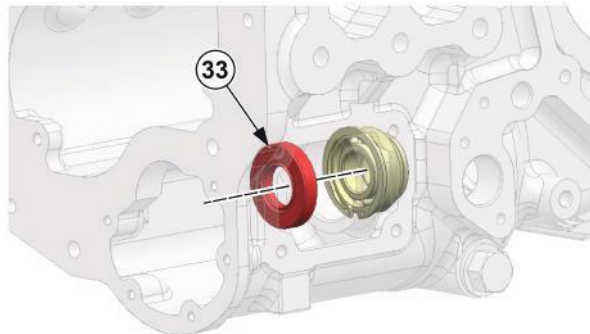

ITL000635

Step 17:

1. Insert the shifter sleeve 4WD (34) in the differential housing.

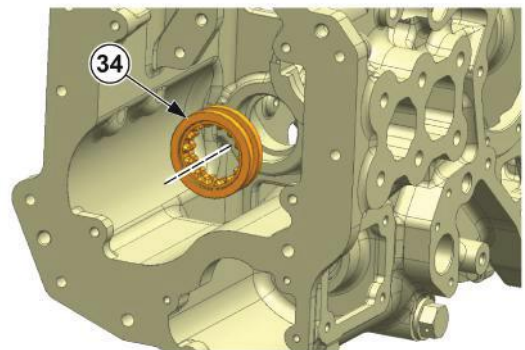

ITL000636

Step 18:

1. Insert the driven gear 4WD (35).

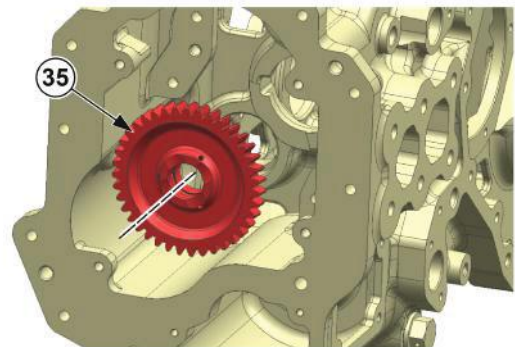

ITL000637

25. ASSEMBLY OF DIFFERENTIAL HOUSING

Step 19:

1. Assemble the ball bearing 6304 (36), spacer (37) and 4WD output shaft (38) in housing as shown in the figure.

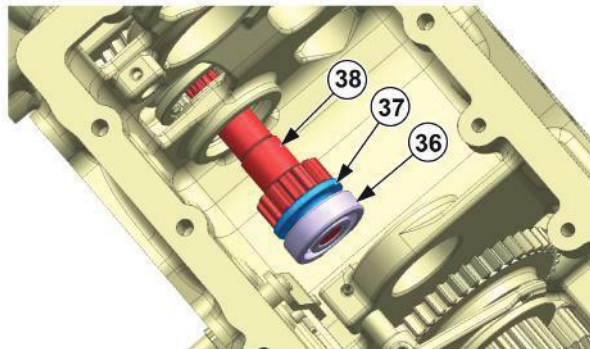

ITL000638

Step 20:

1. Insert the internal circlip (39).

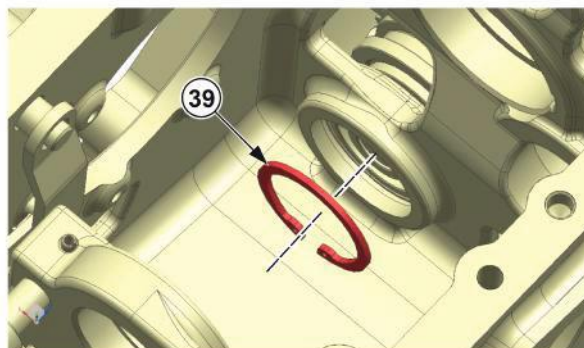

ITL000639

Step 21:

1. Insert the fork 4WD (40).

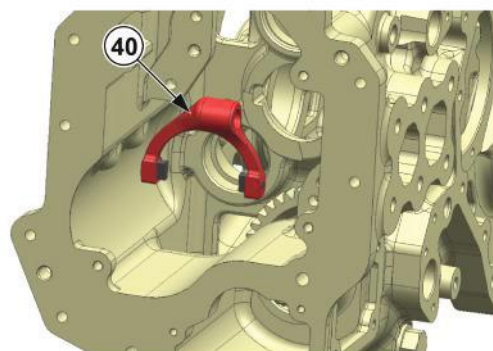

ITL000640

Step 22:

1. Insert the pivot rod (41).

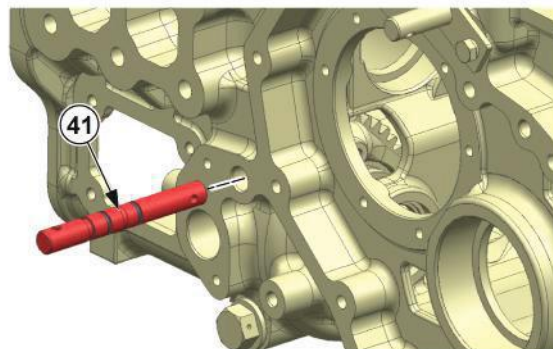

ITL000641

25. ASSEMBLY OF DIFFERENTIAL HOUSING

Step 23:

1. Insert the nut (43) and bolt (42). Tighten the bolt (42) as per torque specification.

| Specification |
|-----------------------------------------|
| Torque :- 13.28-16.96 lbf.ft (18-23 Nm) |

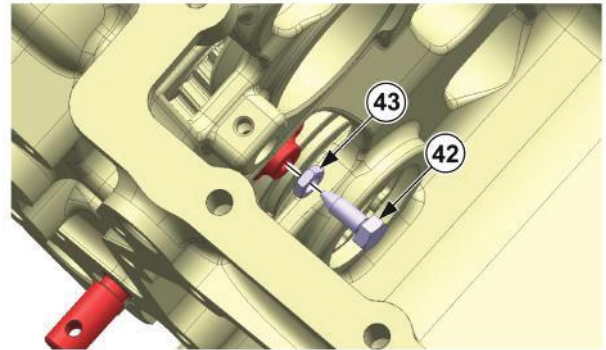

ITL000642

Step 24:

1. Assemble the locking plate (45), Apply the loctite 5188 and tighten the bolt (44) as per torque specification.

| Specification |
|-----------------------------------------|
| Torque :- 13.28-16.96 lbf.ft (18-23 Nm) |

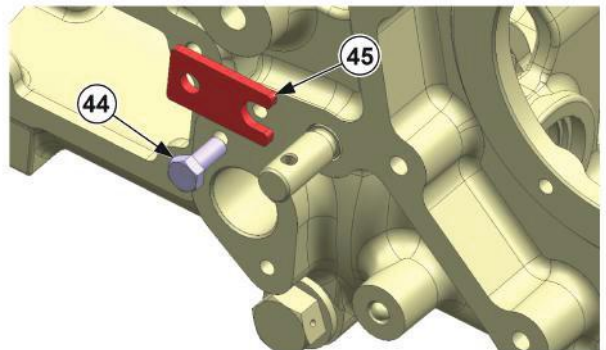

ITL000643

Step 25:

1. Insert the ball (46), spring (47) and assemble the pivot lug (45) in housing.

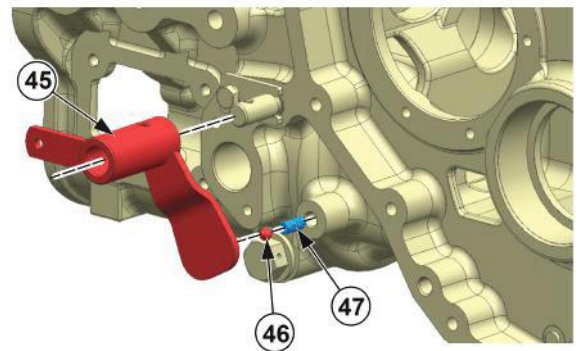

ITL000644

Step 26:

1. Insert the split pin (48) by using tool.

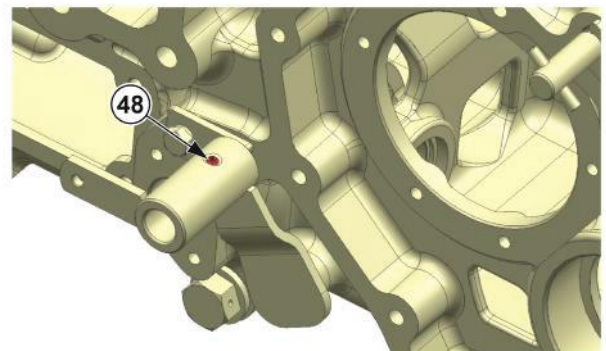

ITL000645

25. ASSEMBLY OF DIFFERENTIAL HOUSING

Step 27:

1. Assemble the connecting sleeve PTO (49) and ball bearing (50).

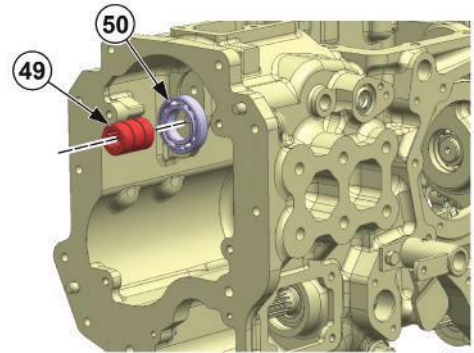

ITL000646

Step 28:

1. Assemble the external circlips (52) in connecting sleeve PTO.
2. Assemble the internal circlip (51) in differential housing.

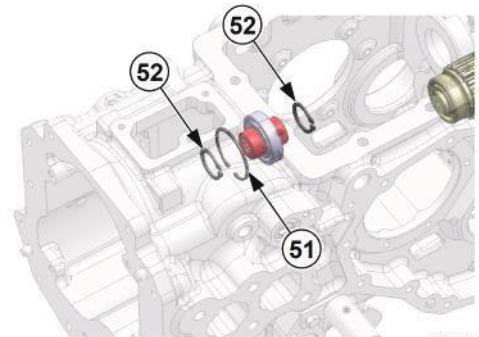

ITL000647

Step 29:

1. Insert the ball bearing 6304 (53) in housing.

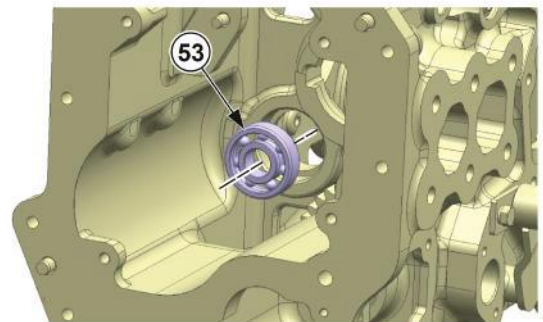

ITL000648

Step 30:

1. Assemble the ball bearing 6206 (54), range lay shaft (55) and idler gear 4WD (56). Insert the assembly into the housing as shown in the figure.

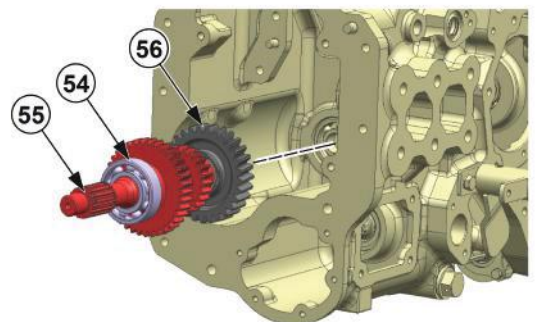

ITL000649

25. ASSEMBLY OF DIFFERENTIAL HOUSING

Step 31:

1. Assemble the PTO drive shaft (57) and ball bearing 6005 (58).

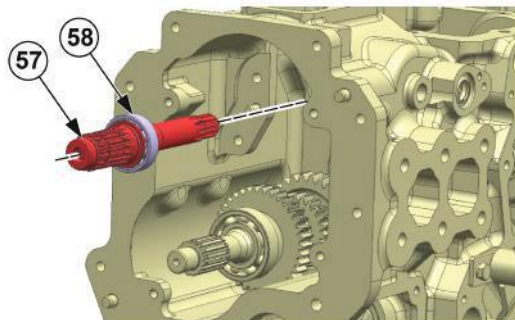

ITL000650

Step 32:

1. Assemble the tail pinion shaft (59) and taper roller bearing (60).

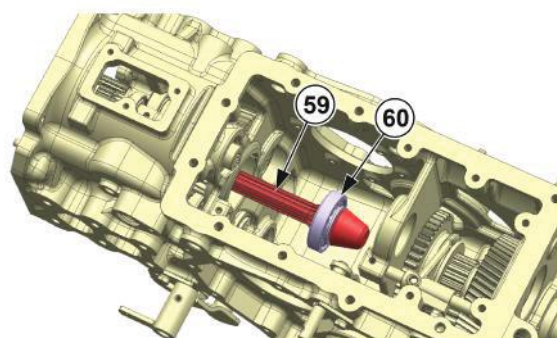

ITL000651

Step 33:

1. Insert spring (61), pin (62) and ball (63) in fork.
2. Assemble the shifter sleeve (68), hub (67), fork (64), dog gear low (66) and driver gear 4WD (65).

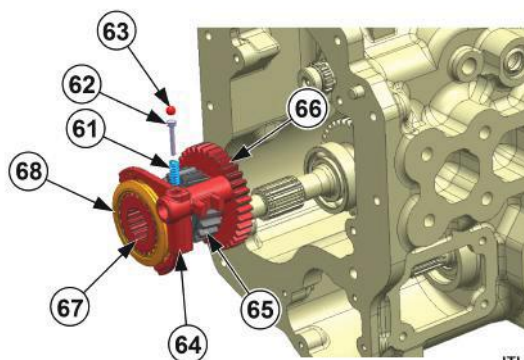

ITL000652

Step 34:

1. Insert the shifter lug (69) in differential housing.

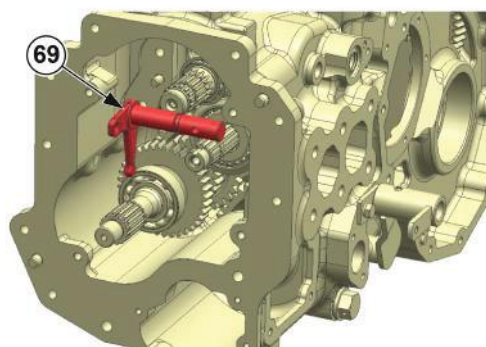

ITL000653

25. ASSEMBLY OF DIFFERENTIAL HOUSING

Step 35:

1. Insert the shifter rod (70) in differential housing.

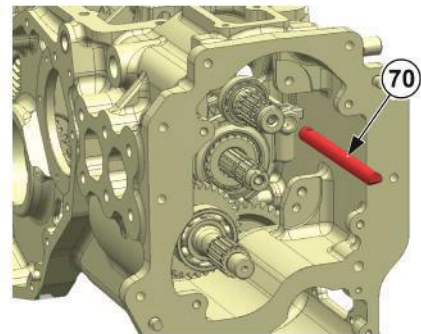

ITL000654

Step 36:

1. Insert the split pin (71) by using tool.

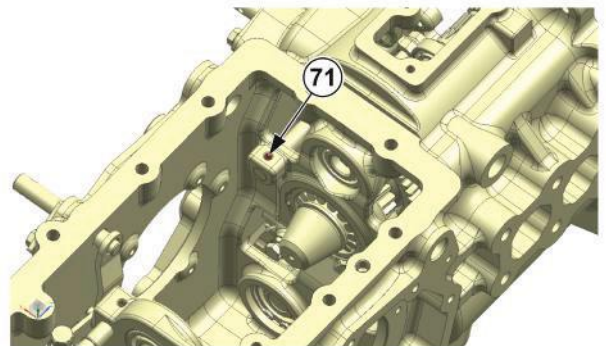

ITL000655

Step 37:

1. Insert the dog gear high Z-24.

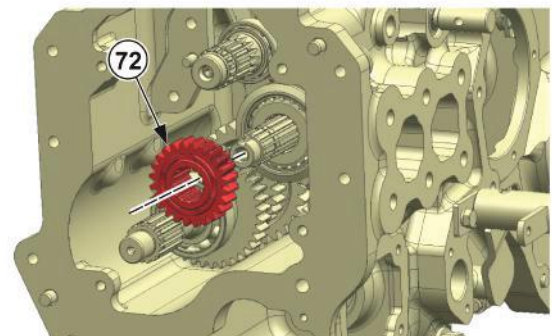

ITL000656

Step 38:

1. Insert the shim and thrust washer an assemble the circlip.

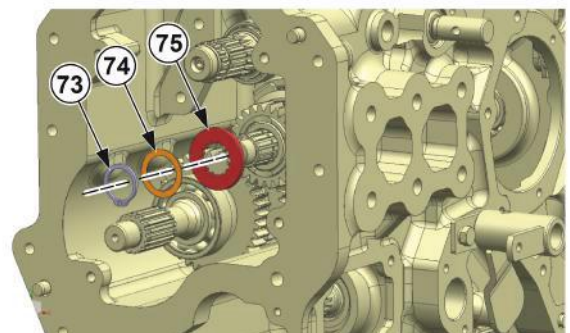

ITL000657

25. ASSEMBLY OF DIFFERENTIAL HOUSING

Step 39:

1. Insert the shim (76) in bearing holder plate (77) as shown in the figure.

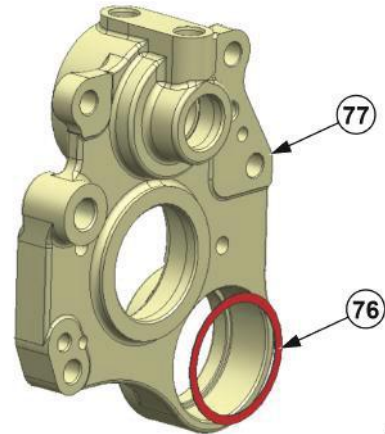

ITL000658

Step 40:

1. Insert the bearing (78) in bearing holder plate (77) and tighten the bolts (79) as per torque specification.

| Specification |
|---------------------------------------------|
| Torque :- 22.13 - 29.50 lbf.ft (30 - 40 Nm) |

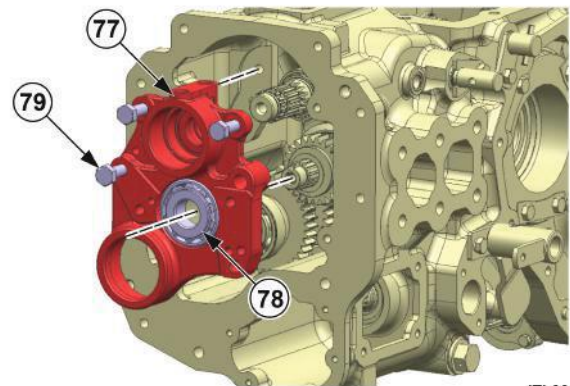

ITL000659

Step 41:

1. Insert the locking washer (81) and tight the withdrawal nut (80).

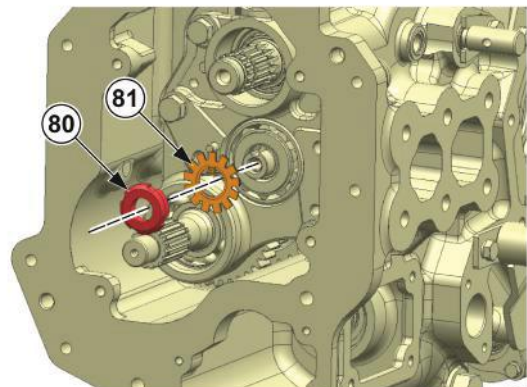

ITL000660

Step 42:

1. Assemble the bearing holder bracket (82) and ball bearing 6007 (84). Insert the bearing holder bracket assembly in housing.
2. Tighten the bolts (83) as per torque specification.

| Specification |
|-------------------------------------------|
| Torque :- 22.13 - 29.50 lbf.ft (30-40 Nm) |

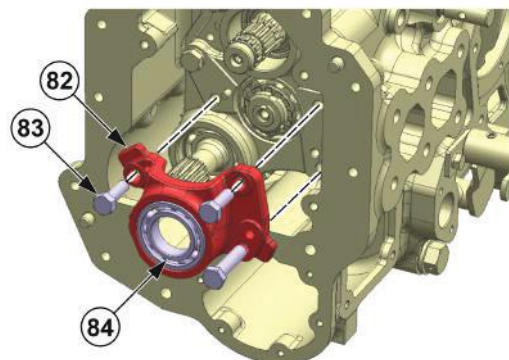

ITL000661

25. ASSEMBLY OF DIFFERENTIAL HOUSING

Step 43:

1. Insert the driven gear Z-19 (85).

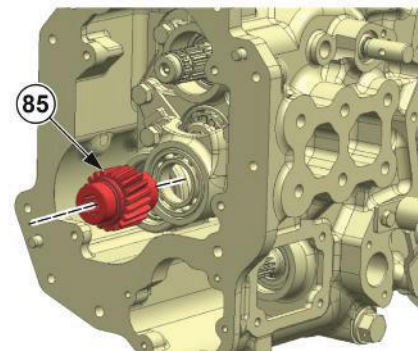

ITL000662

Step 44:

1. Insert the circlip (86).

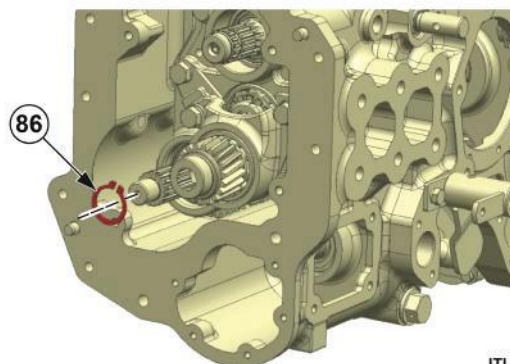

ITL000663

Step 45:

1. Insert the driven gear Z-20 (87).

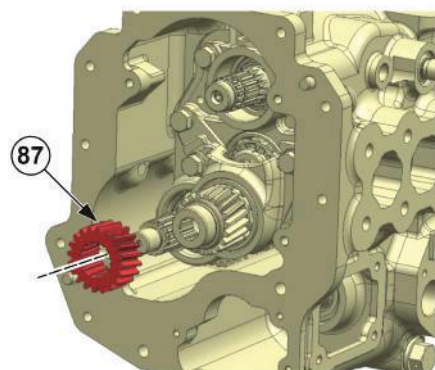

ITL000664

Step 46:

1. Insert the circlip (88).

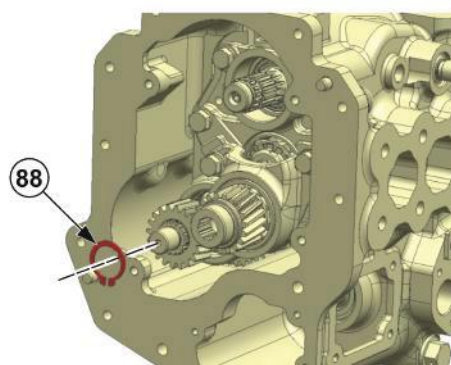

ITL000665

25. ASSEMBLY OF DIFFERENTIAL HOUSING

Step 47:

1. Insert the circlip (89).

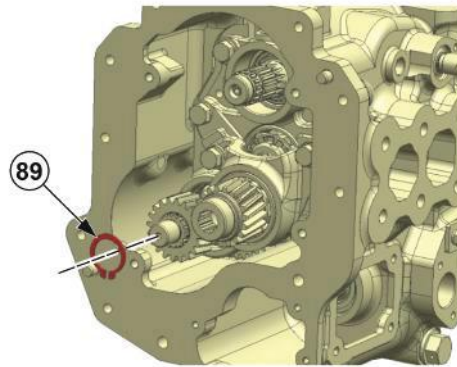

ITL000666

Step 48:

1. Insert the needle bush (90).

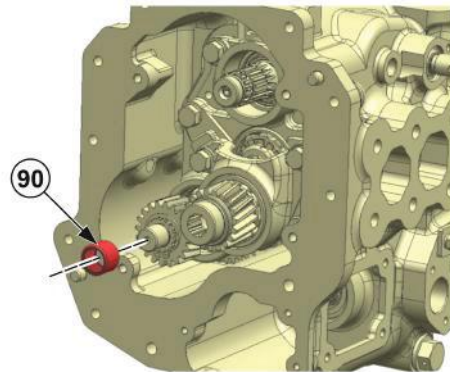

ITL000667

Step 49:

1. Insert the ball bearing 6007 (91) as shown in the figure.

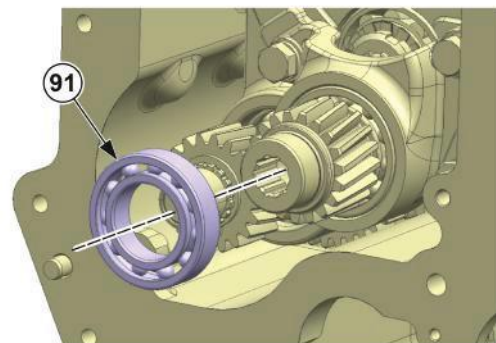

ITL000668

Step 50:

1. Insert the ball bearing 6005 (92) as shown in the figure.

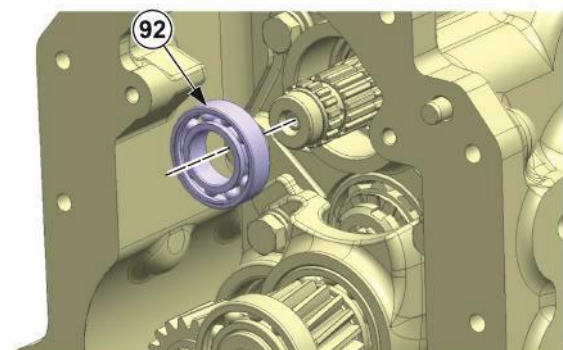

ITL000669

25. ASSEMBLY OF DIFFERENTIAL HOUSING

Step 51:

1. Insert the grub screw (94) and hub PTO clutch (93) as shown in the figure.

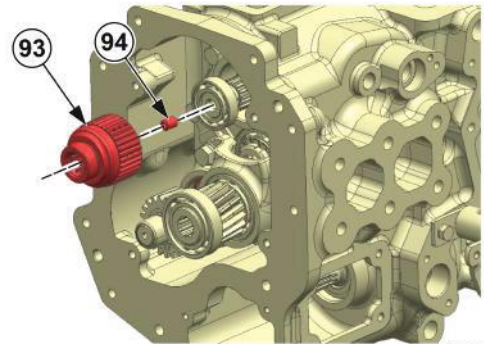

ITL000670

Step 52:

1. Insert the JMI PTO clutch assembly (95).

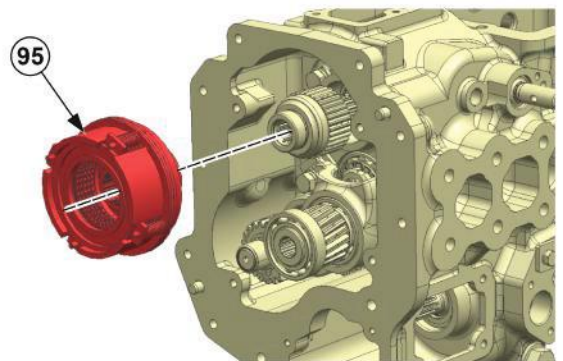

ITL000671

Step 53:

1. Insert the shifter lug (96) in differential housing as shown in the figure.

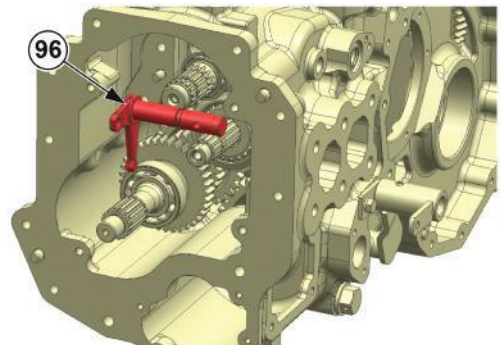

ITL000672

Step 54:

1. Insert the locking strip (99) and tight the bolt (97) with washer (98). Tighten the bolt as per torque specification.

| Specification |
|---------------------------------------------|
| Torque :- 13.28 - 16.96 lbf.ft (18 - 23 Nm) |

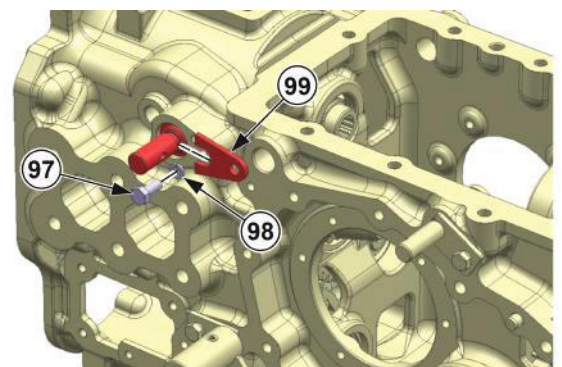

ITL000673

25. ASSEMBLY OF DIFFERENTIAL HOUSING

Step 55:

1. Insert the intermediate plate (100).
2. Insert the bolts (101) & washer and tighten the bolt as per specification.

| Specification |
|--------------------------------------------------------------|
| M10 Bolt Torque :- 25.81-29.50 lbf.ft (35 - 40 Nm.) |
| M12 Bolt Torque :- 44.25 - 51.63 lbf.ft (60 - 70 Nm.) |

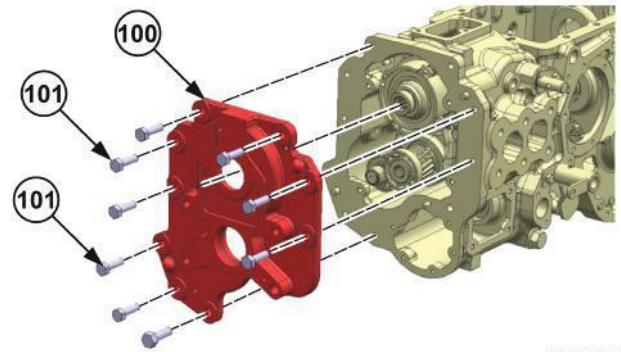

ITL000674

Step 56:

1. Assemble the locking plates (103), differential cage (104), shims (105) and bolts (102) as per requirement.

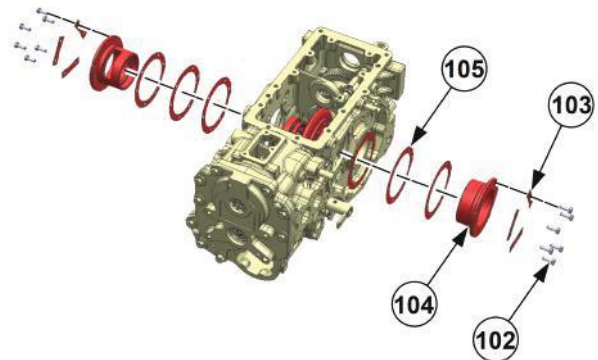

ITL000676

Step 57:

1. Insert the differential cage assembly (106) in housing as shown in the figure.

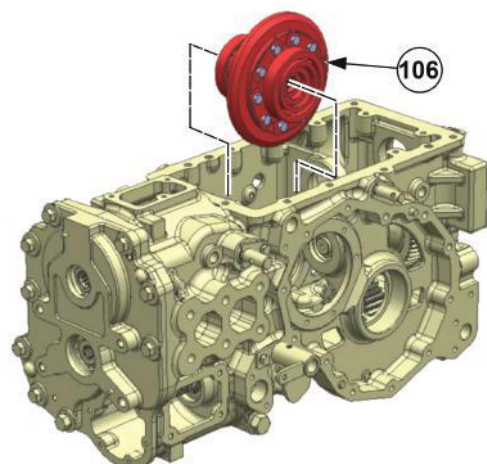

ITL000675

25. ASSEMBLY OF DIFFERENTIAL HOUSING

Step 58:

1. Tight the bolts (102) of differential cage as per torque specification.

| Specification |
|---------------------------------------------|
| Torque :- 13.28 - 16.96 lbf.ft (18 - 23 Nm) |

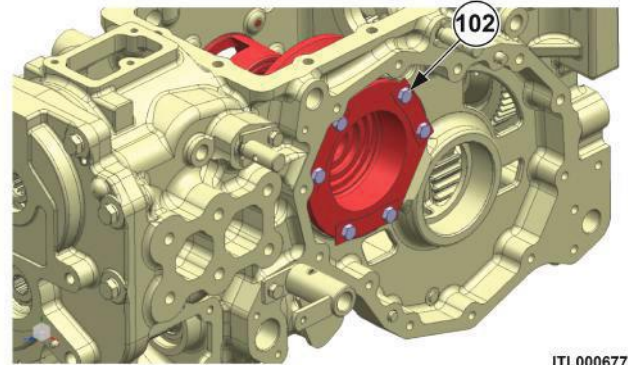

ITL000677

Step 59:

1. Assemble the parking brake switch (108).

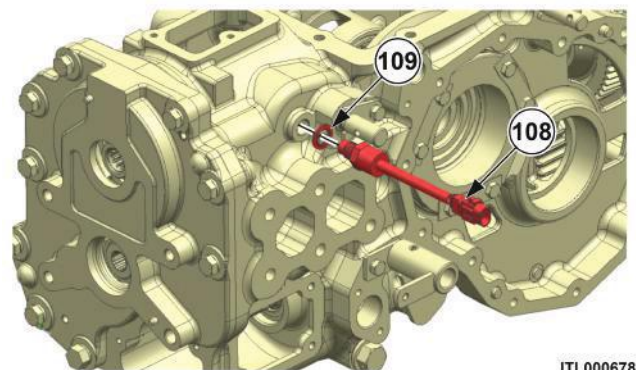

ITL000678

Step 60:

1. Assemble the PTO switch (110).

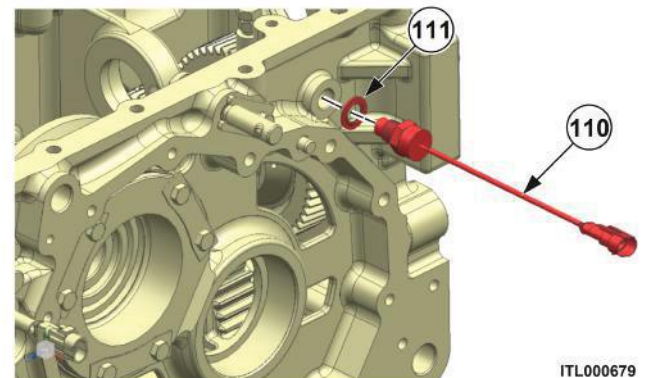

ITL000679

Step 61:

1. Assemble the ball bearing 6205 (113), PTO intermediate shaft (114) and ball bearing 6206 (112) in housing.

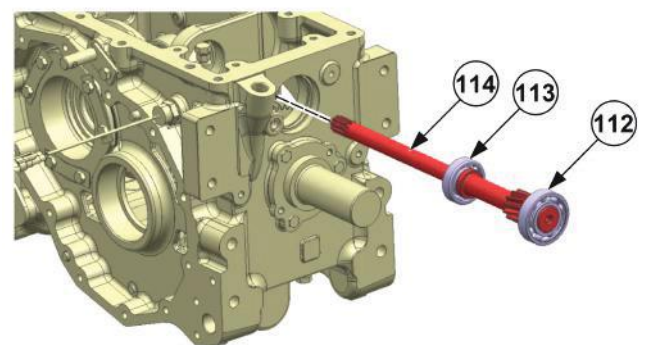

ITL000680

25. ASSEMBLY OF DIFFERENTIAL HOUSING

Step 62:

1. Insert the Shim (115) in housing as shown in the figure.

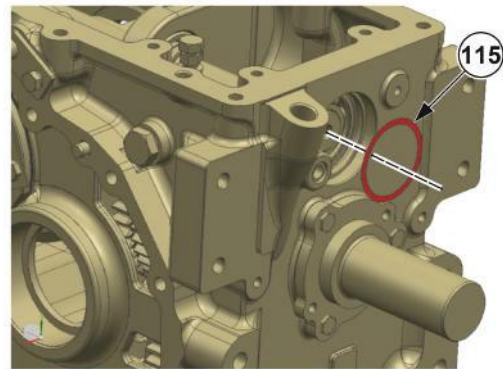

ITL000681

Step 63:

1. Assemble the internal circlip (117) by using tool.
2. Assemble the cap (116) in differential housing.

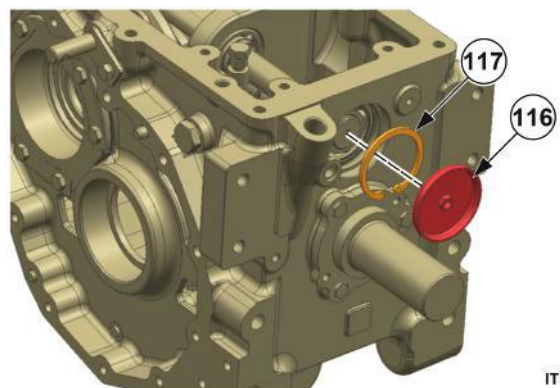

ITL000682

Step 64:

1. Assemble the dipstick (118).

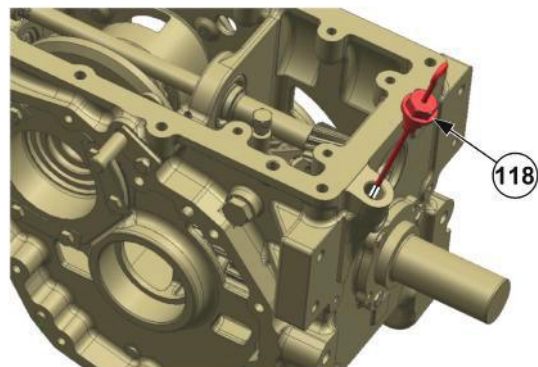

ITL000683

Step 65:

1. Assemble the diff. lock fork (121), spring (122), spacer (120) and diff. lock shaft (119).

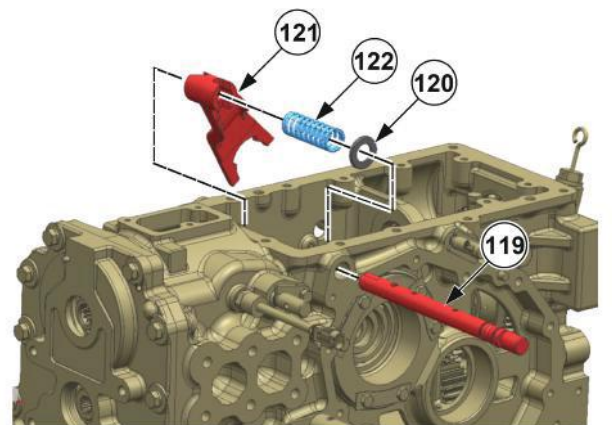

ITL000684

25. ASSEMBLY OF DIFFERENTIAL HOUSING

Step 66:

1. Assemble the locking strip (125).
2. Insert the bolt (123) and washer (124). Tighten the bolt as per torque specification.

| Specification |
|-------------------------------------------|
| Torque :- 13.28-16.96 lbf.ft (18 - 23 Nm) |

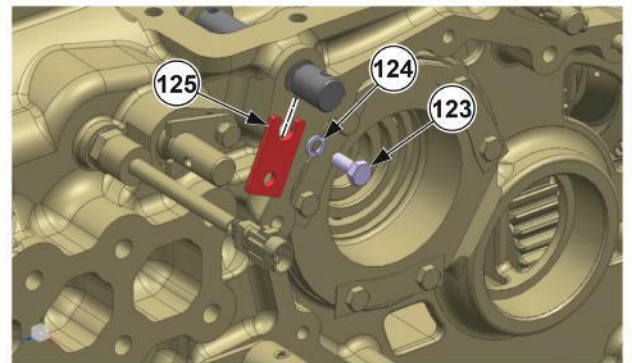

ITL000685

Step 67:

1. Assemble three split pins (127) by using the special tool.

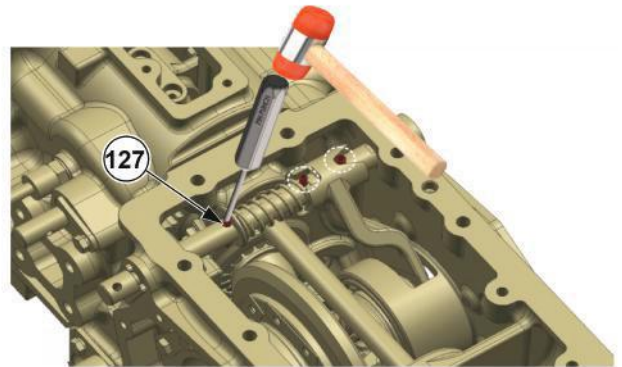

ITL000686

Step 68:

1. Assemble the intermediate plate (129).
2. Tight the bolts (128) as per torque specification.

| Specification |
|---------------------------------------------|
| Torque :- 44.25 - 51.63 lbf.ft (60 - 70 Nm) |

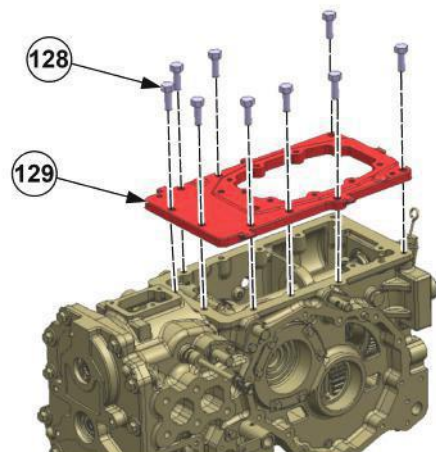

ITL000687

25. ASSEMBLY OF DIFFERENTIAL HOUSING

Step 69:

1. Assemble the PTO valve assembly (131).
2. Tight the bolts (130) as per torque specification.

| Specification |
|-------------------------------------------|
| Torque :- 13.28-16.96 lbf.ft (18 - 23 Nm) |

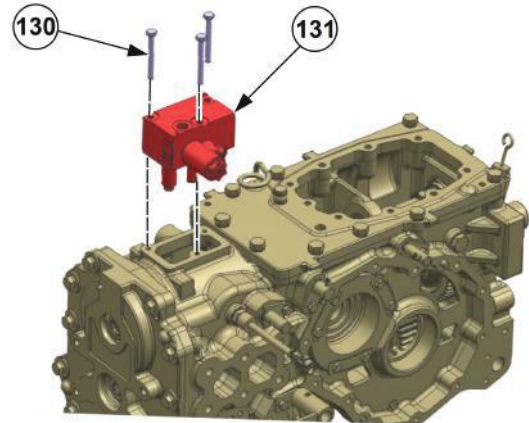

ITL000688

Step 70:

1. Assemble the rear axle (134) and trumpet housing (132).
2. Tight the bolts (133) as per torque specification.

| Specification |
|---------------------------------------------|
| Torque :- 29.50 - 33.19 lbf.ft (40 - 45 Nm) |

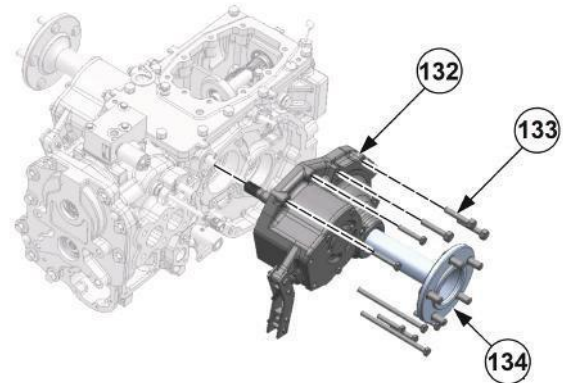

ITL000689

26. ASSEMBLE OF PUMP

Assemble of pump

IMPORTANT :-

1. Wash all of the parts with the treated oil and the air blow completely sure that the washed parts are free from dust and other foreign matter.
2. Handle them with care so that they will not be dented or damaged.
3. Always replace oil seals and bearings with the new ones.
4. Tighten all the threads with the specified torque.
5. Apply lithium grease to the oil seals and the O-rings in advance. (In particular, the oil seal lips must be greased.)

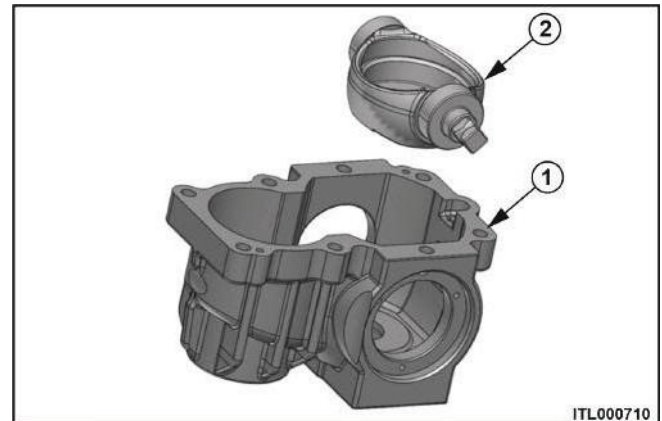

Step 1:-

Assemble of the swash plate

1. Assemble the swash plate (2) into the case (1).



Be careful to the trunnion shaft direction.

2. Insert the O-ring (5) in cover (4) and press-fit the oil seals (6) from steps part of the covers (4) to the depth 0.5 mm.
3. Make the gap of the bushing (7) and the slit of cover (4) to the same position and press-fit the bushing to the cover (4).
4. Assemble the covers (4) to the both side of the case (1).



Assemble direction of the trunnion cover. Assemble the cover so that the slit part faces the gasket mounting side of the case (1).

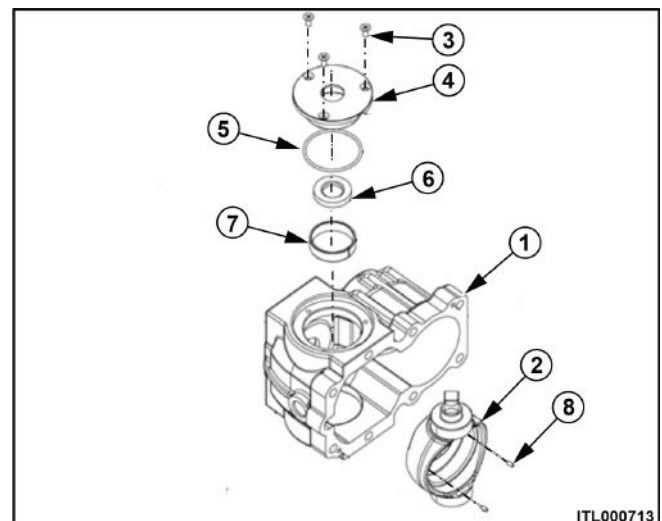

26. ASSEMBLE OF PUMP

5. Tighten six screws (3) on both sides by the tool as per torque specification.

| Specification |
|----------------------------|
| Torque – 6.86 ± 0.6 NM |

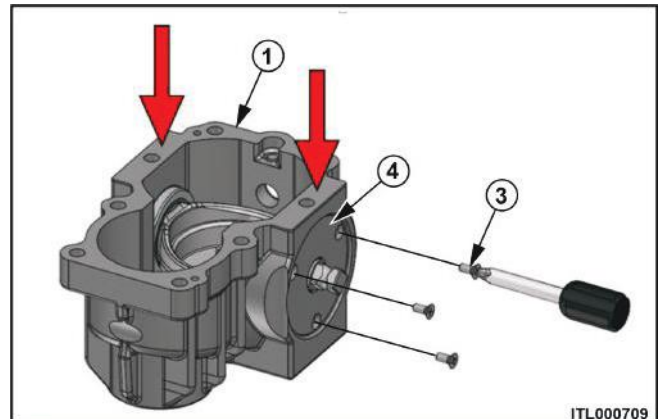

Step 2:-

Assemble of the pump shaft

1. Press-fit the shaft (5) into the bearing (7) using the tool as shown in the figure.

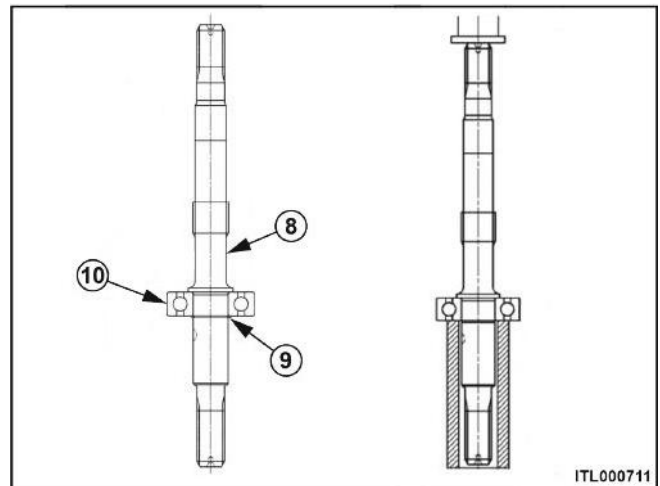

2. Insert the snap ring (6) into the shaft (5).

3. Assemble the pump shaft assy into the case (1) as shown in the figure.

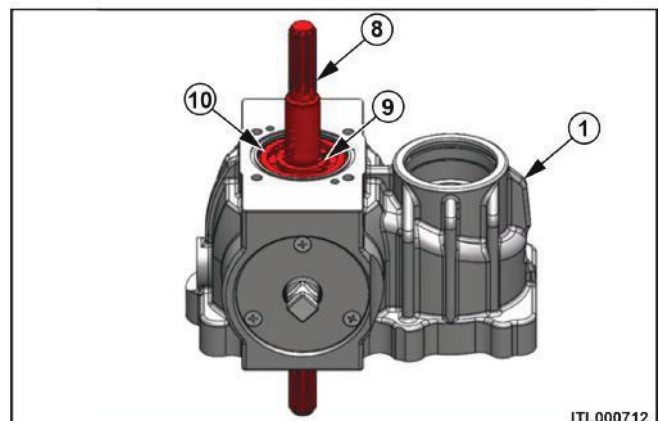

26. ASSEMBLE OF PUMP

Step 3:-

Assemble of the charge pump

1. Assemble the collar (13), the O-ring (11), and two pins (12) to the case (1).

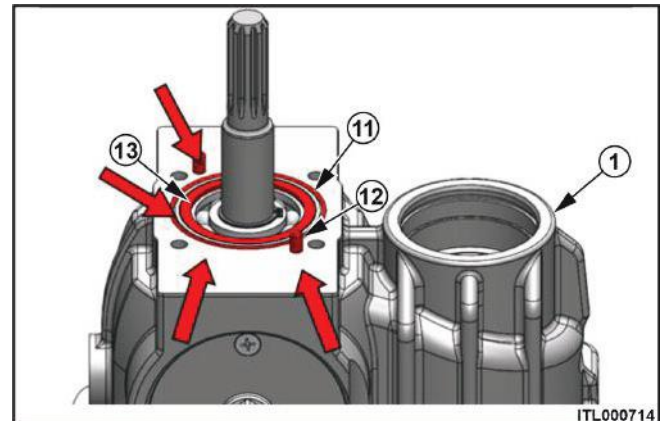

2. Assemble the plate (14) to the case (1).

3. Assemble the key (15) into the key groove on the pump shaft (1) and assemble the trochoid rotor assembly (16).

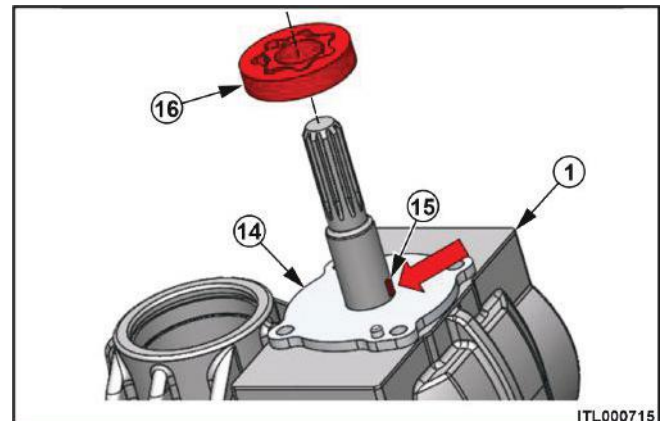

IMPORTANT :-Assemble direction of the trochoid rotor assembly. Assemble with the identification mark “●” of the inner and outer rotors on the same side.

4. Insert the oil seal and the snap ring in the charge pump case (17). Assemble the charge pump in the case (1).

5. Tighten four socket head bolts (18) as per torque specification.

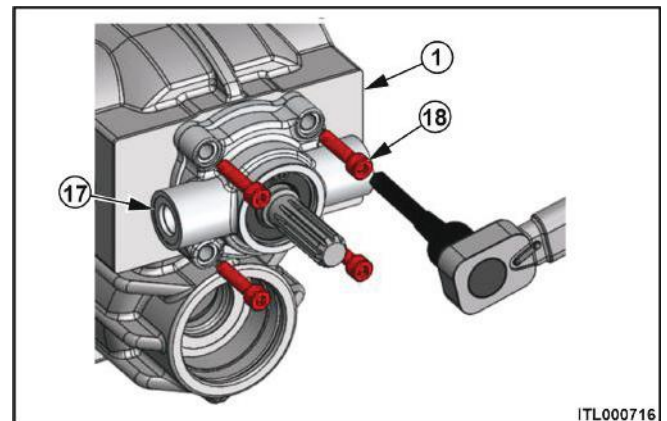

Specifications

Torque :- 17.7 ± 0.7 N.M

26. ASSEMBLE OF PUMP

Step 4:-

Assemble of the motor shaft

1. Press fit the ball bearing (20) in motor shaft (19) and insert the snap ring (21) in the motor shaft as shown in the figure.

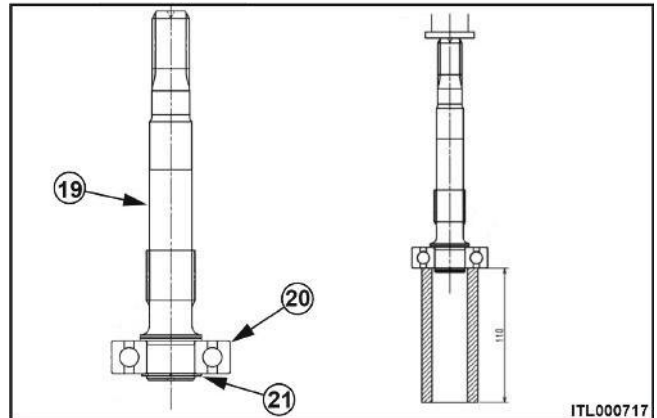

2. Assemble the motor shaft into the case (1).

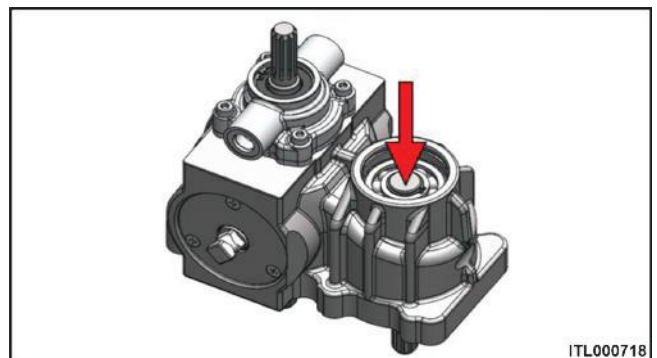

3. Insert the O-ring to the cap (23). Assemble the cap (23) and the snap ring (22) to the case (1).

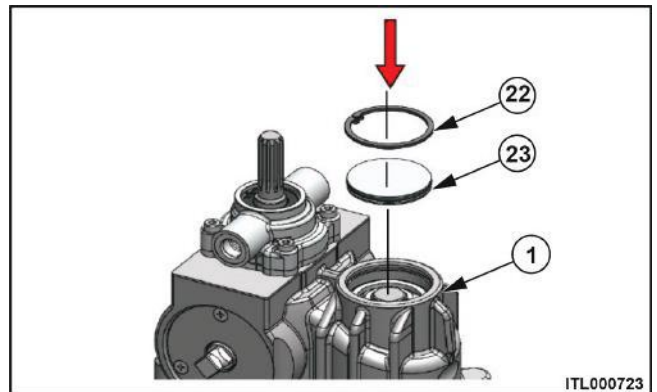

Step 5:

1. Assemble the thrust plate (25) to the case (1).

Step 6:

Assemble of the pump cylinder block assy

1. Assemble two pins (26) to the swash plate.

2. Assemble the thrust plate (24) to the swash plate (2).

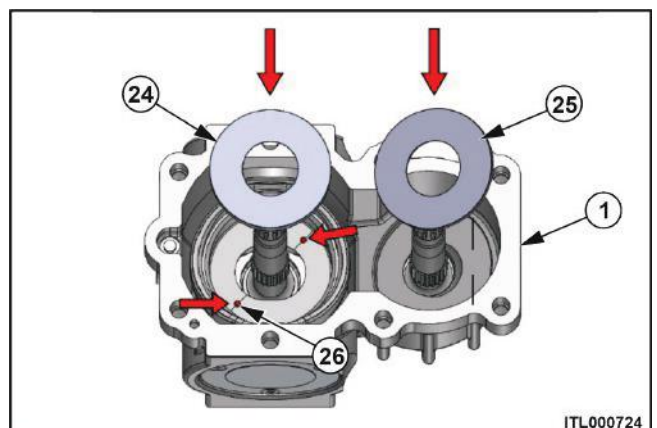

Align the holes of the thrust plate (24) with two pins (24) on the swash plate (2).

26. ASSEMBLE OF PUMP

3. Assemble the pump cylinder block assy.

Cylinder block ASSY components :-

27 — Cylinder block

28 — Spring holder

29 — Retainer plate

30 — Piston

31 — Retainer holder

32 — Pins

33 — Spring

34 — Spring holder

35 — Snap ring

4. Assemble the motor cylinder block assy.

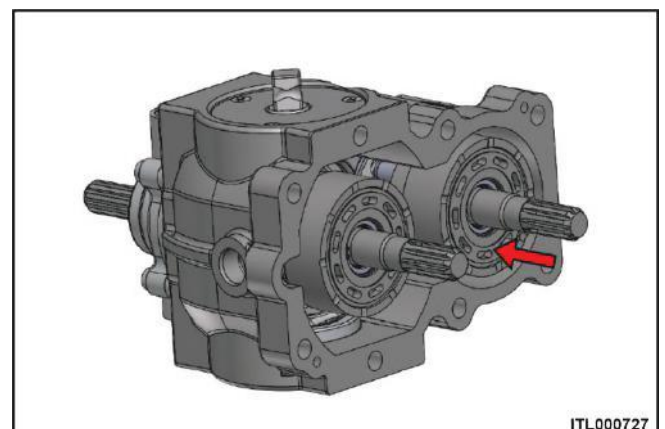
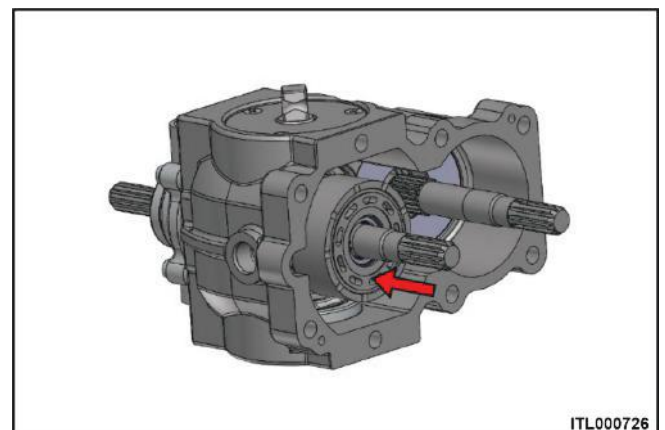
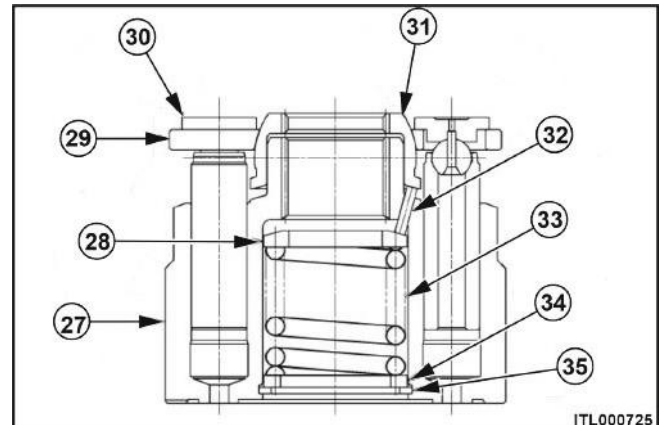

Apply the hydraulic fluid to the sliding surface of the cylinder block before assembling the cylinder block assy.



Pay attention not to drop the pins (21) out. Make sure that the pins (21) are not dropped after assembled for both sides (Motor and Pump side).

Step 7:-

Assembling of the port block ASSY.

1. Assemble two pins (36) to the case (1).

2. Assemble the spring (37) to the case (1).

IMPORTANT :- In order not to drop the spring off, apply the lithium grease to the spring and the case (1) before assembling.

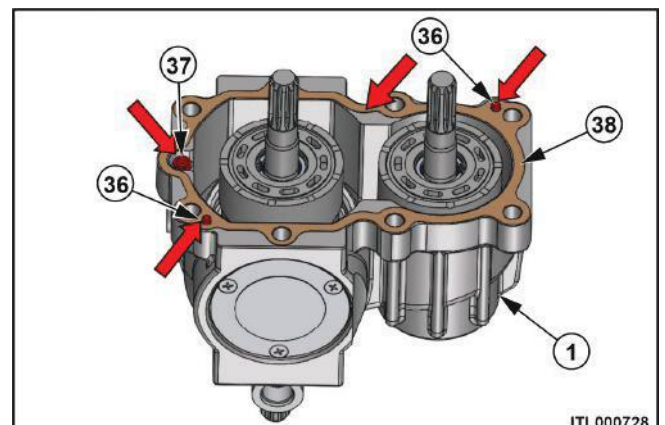

26. ASSEMBLE OF PUMP

3. Apply the grease thinly on the gasket (38), and assemble the gasket (38) to the case (1).
4. Assemble two pins (39), the valve plate (40) and (41) in to the port block assy (43).



In order not to drop the valve plates off, apply the grease between the valve plates and the port block before assembling.



It is the motor side that there are the notch (V notch) at both ends of the long holes.



The other surface is up side. (Pump and motor are same.) Pay attention to direction of assembling.

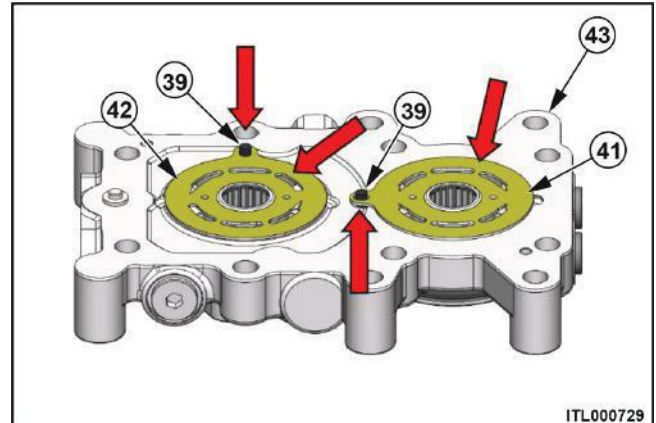

ITL000729

5. Assemble the valve (44) to the port block assy.



In order not to drop the valve off, apply the grease between the valve and the port block.

6. Align the holes in the port block assy (43) with two pins on the case (1).

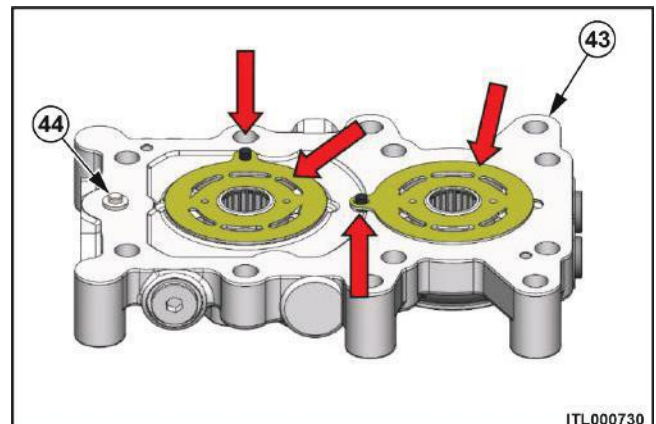

ITL000730

7. Align the spring and the valve.

IMPORTANT :-Apply the hydraulic fluid to the sliding surface of cylinder block enough before assembling.

8. Tighten eight socket head bolts (44).Apply the torque as per specification.

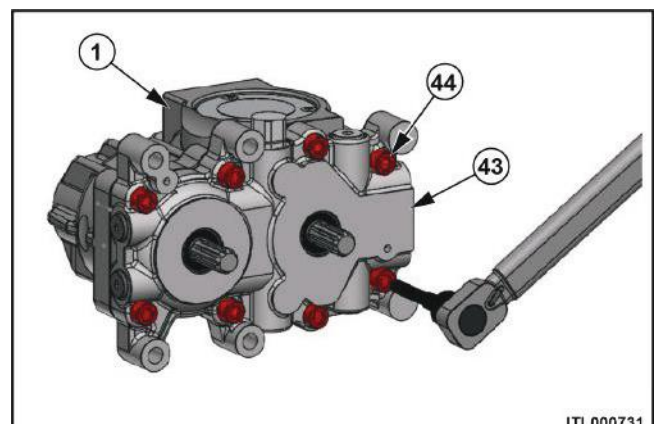

ITL000731

Specification

Torque :- 70.6±7 N.M

26. ASSEMBLE OF PUMP

9. After assembling is completed, make sure that the shaft (8), (19) and trunnion shaft rotate smoothly with a monkey wrench and so on.

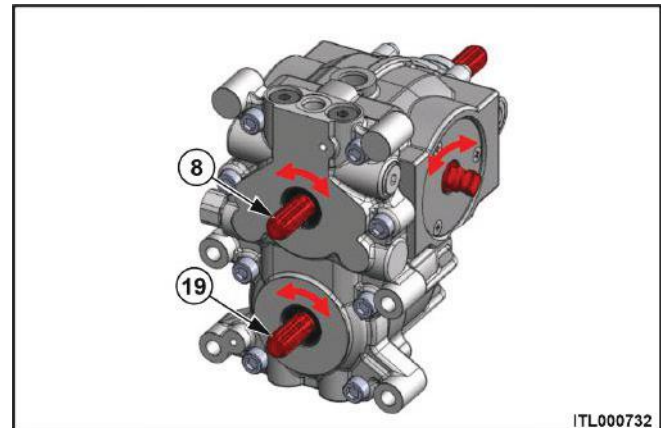

27. DIFFERENTIAL BACKLASH ADJUSTMENT

Differential Backlash Adjustment

1. While slowly rotating differential carrier, lightly tap carrier with a soft-faced mallet to make sure bearing on other side of ring gear is seated.

2. Attach a dial indicator to housing, as shown, with contact point positioned on ring gear splines.

NOTE: Ring gear carrier is not preloaded and will have normal side-to-side movement.

3. While holding input shaft, move carrier and ring gear to determine differential backlash. Backlash should be within specification.

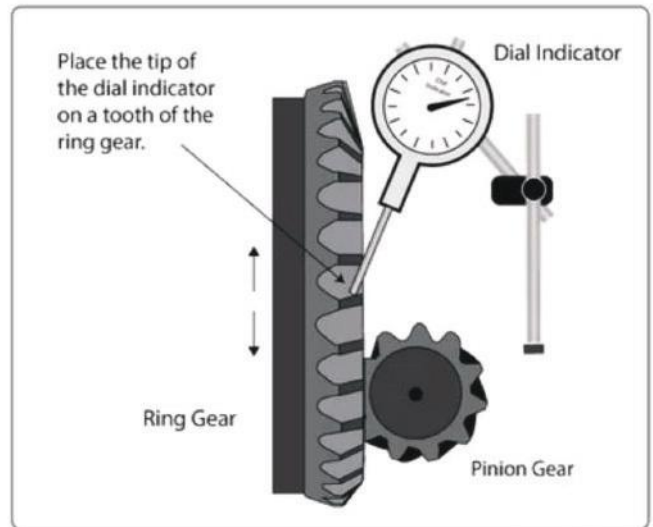

ITL000690

| Specification |
|------------------------------------------------|
| Differential Backlash—Distance ...0.18—0.33 mm |

4. To adjust backlash, remove six cap screws (C) Turn differential quill (A) to specified angle and install cap screws in the two threaded holes. Use cap screws to draw out the quill.

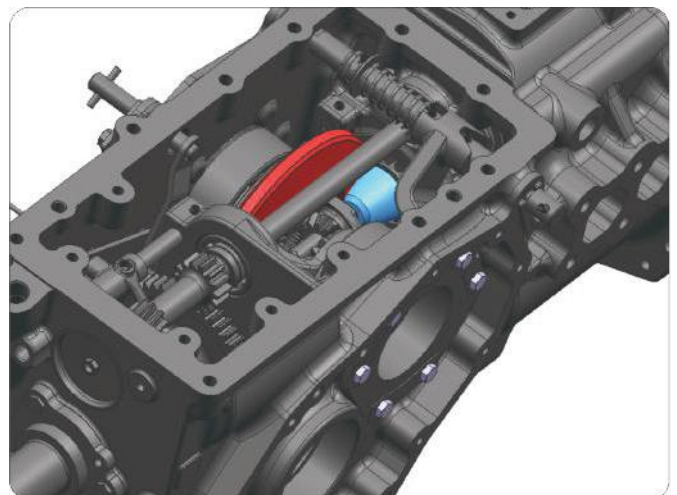

ITL000691

| Specification |
|-----------------------------------|
| Differential Quill—Angle30° |

5. Remove shims (B) to decrease backlash and add shims to increase.

6. Recheck backlash after removing or adding shims.

7. Tighten differential cap screws to specification.

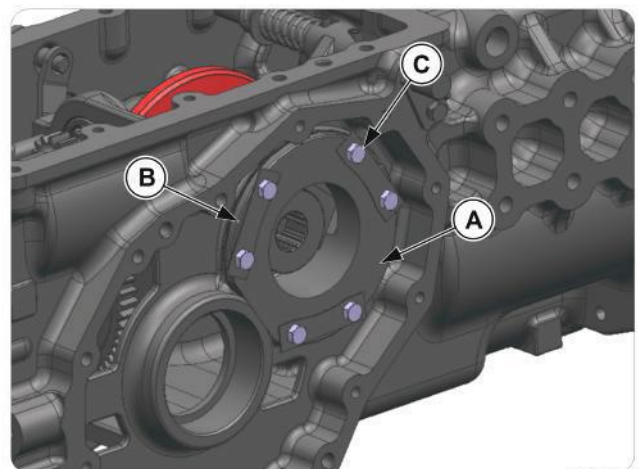

ITL000692

| Specification |
|-----------------------------------------------------|
| Differential Cap Screw—Torque.....52 N•m (43 lb-ft) |

A—Differential Quill

B—Shim

C—Cap Screw (6 used)

IMPORTANT: Always check and adjust backlash after cone point adjustment has been made.

28. PRESSURE MEASUREMENT PROCEDURE

Pressure measurement procedure

To verify ITL new measurement instruments, we propose pretesting below before KYB measurement.

1. Engine stalling test
2. Back pressure test

1. Engine stalling test

Measuring points are below, please measure as possible.

| Table.1 — sensor | | | |
|------------------|----------|-------------|---------------------------|
| No. | Subject | Measure | Sensor |
| 1 | Pga | Pressure | Greater than 40MPa sensor |
| 2 | Pgb | Pressure | Greater than 40MPa sensor |
| 3 | B2 | Pressure | Greater than 5MPa sensor |
| 4 | T | Pressure | Greater than 1MPa sensor |
| 5 | S | Pressure | Greater than 1MPa sensor |
| 6 | Tank Oil | Temperature | Thermometer |
| 7 | Ambient | Temperature | Thermometer |

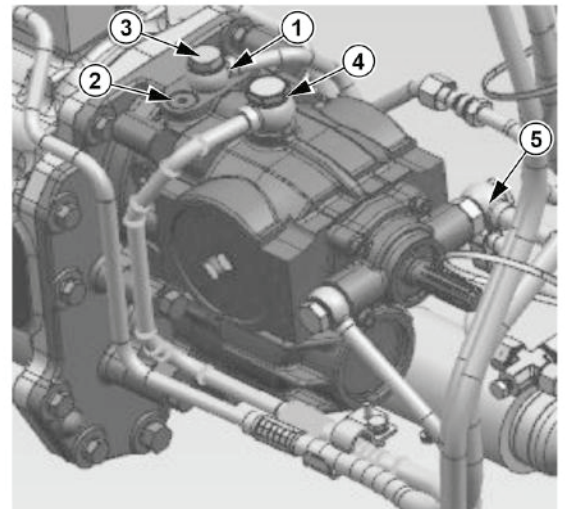

ITL001066

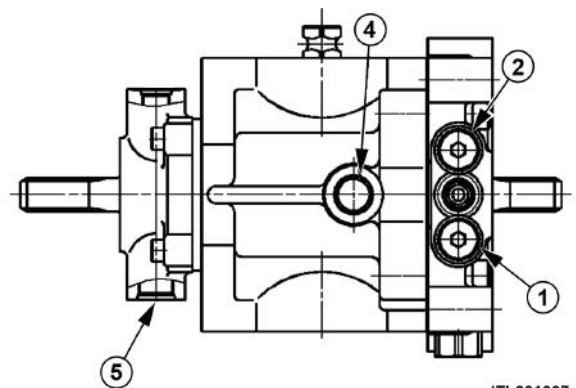

ITL001067

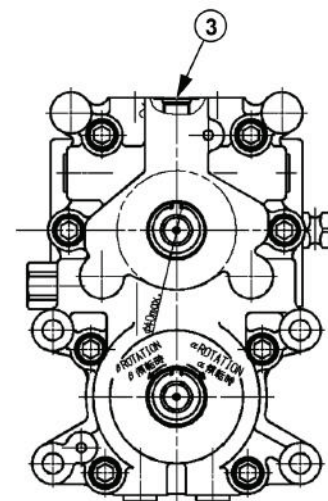

ITL001068

28. PRESSURE MEASUREMENT PROCEDURE

| Table.2 —Engine stalling test | | | | | | |
|-------------------------------|-----------|------------|--------------------|------------|---------------|------|
| Test condition | | | | Result | | |
| No. | Gear | Engine RPM | Pedaling□ speed | Stall(Y/N) | Peak pressure | |
| | | | | | 1 Pga | 2Pgb |
| 1 | High Gear | Maximum | rapidly | | | |
| 2 | | | Slowly | | | |
| 3 | | Minimum | rapidly | | | |
| 4 | | | Slowly | | | |
| 5 | Low Gear | Maximum | rapidly | | | |
| 6 | | | Slowly | | | |
| 7 | | Minimum | rapidly | | | |
| 8 | | | Slowly | | | |

Test flowchart

Engine stalling test

1. Installing high pressure sensors (Table.1 1,2)
2. Installing low pressure sensors (Table.1 3,4,5)
3. Installing thermometers (Table.1 6,7)
4. Engine start and warm up hydraulic oil of the tank till roughly 50°C.
5. Stalling test (Table.2)
6. Filling result out in Table.2

28. PRESSURE MEASUREMENT PROCEDURE

2. Back pressure test

Measuring points are same as the stalling test

| Table.3 — Back pressure test | | | | | | | |
|------------------------------|-----------|------------|-------------------------------------|----------|------------------|-----|-----|
| Test condition | | | | Result | | | |
| No. | HST Lever | Engine RPM | Oil temp | Oil temp | Average pressure | | |
| | | | | | 3 B2 | 4 T | 5 S |
| 1 | Neutral | Low | as low as possible (in the morning) | | | | |
| 2 | | 1500 | | | | | |
| 3 | | 2000 | | | | | |
| 4 | | 2500 | | | | | |
| 5 | | High | | | | | |
| 6 | | Low | 50°C at Tank | | | | |
| 7 | | 1500 | | | | | |
| 8 | | 2000 | | | | | |
| 9 | | 2500 | | | | | |
| 10 | | High | | | | | |

Test flowchart

Back pressure test

1. Installing high pressure sensors (table.1 1,2)
2. Installing low pressure sensors (table.1 3,4,5)
3. Installing thermometers (table.1 6,7)
4. Start logging a data and then Engine start.
5. Back pressure test (No.1 to 5 ,Table.3)
6. Warm up hydraulic oil of the tank till roughly 50°C
7. Back pressure test (No.6 to 10 ,Table.3)
8. Filling result out in Table.3

29. TROUBLESHOOTING

Troubleshooting

| GEAR BOX | | | |
|----------|-----------------------------------------------|----------------------------|--------------------------------------------------------------------------------------|
| S. No. | PROBLEM | PROBABLE CAUSES | REMEDIES |
| 1 | NOISE | | |
| | Humming (a peccutior noise) | Wear on gear teeth flank | Replace the gear |
| | | Damage on gear teeth flank | Replace the gear |
| | Metallic grinding | Oil level low | Top up oil level |
| | Whine (Bullet passing sound) | Backlash less | Correct the back lash either by replacing gear on housing. |
| | | Gear machining improper | Replace the gear |
| | Hissing (Leaking noise tent-tire to air lack) | Worn out bearing | Replace the bearing |
| | | Bearing ball/race pitted | Replace the bearing |
| | Ratting (Ruppict series of short loud noise) | Backlash more | Correct the back lash either by replacing gears or housing. |
| | | Bearing seat loosen | Replace the gearing or replace the housing. |
| | | Bearing play more | Replace the gearing |
| | | Excessive end play | Correct the end play by tightening the hex retaining nut or replacing spacers/gears. |
| | Knocking (Noise of sharp blue) | Dent on the gear tooth | Remove the dent by polishing |
| | | Gear tooth damage | Replace the gear |
| | | Foreign matter present | Clean the gear train and strain the oil |

29. TROUBLESHOOTING

| S. No. | PROBLEM | PROBABLE CAUSES | REMEDIES |
|--------|-------------------|---------------------------------------|-------------------------------------------------------------|
| 2 | HARD SHIFTING | Insufficient oil | Top up the oil |
| | | Detent lock assy. Tight | Replace detent - retaining spring |
| | | Bent in shifter rod | Replace the shifter rod |
| | | Gear tooth battered | Replace the gear |
| | | Sliding Gears tight on shaft | Free the gear shaft by polishing or by replacing gear/shaft |
| | | Pilot bearing jam | Replacing the bearing |
| | | Excessive clutch free paly | Adjust & correct free play |
| | | Inter-lock pin tight | Loosen the pin by polishing |
| | | Clutch is not disengaging | Adjust & correct |
| 3 | GEAR SLIPPING OUT | Incomplete gear engaging | Engage gear fully |
| | | Weak detent retaining spring | Replace the spring |
| | | Shifter rod retaining groove worn out | Replace the spring rod |
| | | Gear teeth rounded off | Replace the gear |
| | | Worn out / bent shifter fork | Replace the shifter fork |
| 4 | GEAR STICKING | Detent balls/spring stuck | Free & lubrication |
| | | Scoring on fork | Replace fork |
| | | Clutch not disengaging | Adjust & correct |

29. TROUBLESHOOTING

| Differential | | | |
|---------------------|----------------------------|--------------------------------------------------------|------------------------------------------------------------------------------------|
| S. No. | PROBLEM | PROBABLE CAUSES | REMEDIES |
| 1 | Humming | 1. Incorrect adjustment of crown wheel & Tail pinion. | 1. Re-adjust as per procedure. |
| | | 2. Tooth contact pattern not correct. | 2. Correct the tooth contact pattern by doing the adjustment as per the procedure. |
| 2 | Noise while Accelerating | Tooth contact shifted toward thick end. | Adjust tooth contact pattern as per the procedure. |
| 3 | Noise while Deaccelerating | Tooth contact shifted toward thick end. | Adjust tooth contact pattern as per the procedure |
| 4 | Noise while Turning | Bevel pinion tight on bevel gear. | Correct the gap |
| | | Damaged teeth of bevel | Replace the damaged gear |
| | | Excessive backlash between bevel pinion and bevel gear | Correct the backlash |
| | | Defective axle bearing | Replace the bearing |
| Brake | | | |
| 1 | NO BRAKING ACTION | Pedal linkage broken or disconnected | Replace or repair |
| 2 | POOR BRAKING ACTION | Brake setting improper | Adjust & correct |
| | | Glazed brake liners | Replace |
| | | Glazed brake disc | Correct by machining or replace |
| 3 | BRAKE STUCKING | Linkage retracting spring loose | Replace springs |
| | | Brake disc plate spring tension less | Replace springs |
| | | Binding in linkage | Lubricant & free |

29. TROUBLESHOOTING

| Brake | | | |
|----------|----------------------------------------------------------------------------|-------------------------------------------------------------------------------|---------------------------------------------------------------------------------------------------------------------------------------------------------------------------------------------------------------------------------|
| S. No. | PROBLEM | PROBABLE CAUSES | REMEDIES |
| 4 | NOISE WHILE BRAKING | Loose rivets of brake lining | Correct or replace |
| | | Worn out brake lining | Replace |
| | | Rough or worn out brake disc plate | Correct by machining or replace |
| | | Foreign matter imbedded in lining | Clean the liners |
| | | Loose part in the system | Tighten the loose part |
| HST Pump | | | |
| 1 | The output shaft does not rotate, even though the trunion lever is tilted. | The pressure setting of the charge pressure relief valve changed downward. | <p>Measure the charge circuit pressure. And confirm whether it rises to the specified pressure.</p> <p>If the pressure does not reach the specified pressure, replace their parts.</p> |
| | | The pressure setting of the system pressure relief valve changed downward. | <p>Measure the system pressure at high pressure side. and confirm whether it rises to the specified pressure.</p> <p>If the pressure does not reach the specified pressure, replace their parts.</p> |
| | | Sealing failure of the check valve. (Abnormality of the HST system pressure.) | <p>Measure the charge circuit pressure and system pressure at low pressure side. and confirm whether it rises to the specified pressure.</p> <p>If the pressure does not reach the specified pressure, replace their parts.</p> |

29. TROUBLESHOOTING

| HST Pump | | | |
|----------|--------------------------------------------------------------------------------------------------------|------------------------------------------------------------------------------------------------------|-------------------------------------------------------------------------------------------------------------------------------------------------------------------------------------------------------------|
| S. No. | PROBLEM | PROBABLE CAUSES | REMEDIES |
| 1 | The output shaft does not rotate, even though the trunnion lever is tilted. | Decreasing of the charge flow rate caused by damage or breakage of the charge pump. | <p>Measure the charge circuit pressure. And confirm whether it rises to the specified pressure.</p> <p>If the pressure does not reach the specified pressure, replace their parts.</p> |
| | | HST Aeration to the inside of the HST. | <p>Check the oil level of tank. Check the piping for any abnormality. (Air suction due to seal failure.)</p> <p>Refill the hydraulic fluid. Repair piping. Degas the hydraulic fluid inside in the HST.</p> |
| | | Damage to the main parts of the HST. Damaging or wearing of the input, output shaft or the coupling. | <p>Check the HST output speed rises to specified speed. Check the spline of the coupling not wearing.</p> <p>Replace the coupling. Replace the HST after cleaning the hydraulic circuit equipment.</p> |
| 2 | The rotation of the output shaft does not stop, even though the pedal is returned to neutral position. | Malfunction of the check valve. | <p>Measure the system pressure and check each of the high pressure and the low pressure will change when move forward and backward.</p> <p>Disassemble the HST. Reassemble their parts after washing.</p> |

29. TROUBLESHOOTING

| HST Pump | | | |
|----------|--------------------------------------------------------------------------------------------------------|--------------------------------------------------------------------------------------------------------------------------------------------------------------|---------------------------------------------------------------------------------------------------------------------------------------------------------------------------------------------------------|
| S. No. | PROBLEM | PROBABLE CAUSES | REMEDIES |
| 2 | The rotation of the output shaft does not stop, even though the pedal is returned to neutral position. | Wearing of the movable thrust plate. | Fine-tune the pedal from a neutral position and confirm whether the output shaft stops. If the neutral position cannot be found, replace the parts. |
| | | Pedal is not returned to the neutral because of the increasing of the HST operating torque, the linkage stuck and the decreasing of the return spring force. | Measure the operating torque on the trunnion shaft. Measure the return spring force. Replace the swash plate bushing. Wash the swash plate. Replace the linkage parts. |
| 3 | Lack of the output rotation speed. | Lack of the flow rate in the hydraulic circuit caused by the clogging of the filter or the strainer. | Measure the charge circuit pressure. And confirm whether it rises to the specified pressure. Replace or wash the filter and the strainer. |
| | | Aeration to the inside of the HST. | Check the oil level of tank. Check the piping for any abnormality. (Air suction due to seal failure.) Repair the piping. Refill the hydraulic fluid. Degas from hydraulic oil inside of the HST. |
| 4 | Lack of the output rotation speed. | Decreasing or lack of the charge flow rate caused by the damage or breakage of the charge pump and the valve. | Measure the charge circuit pressure and confirm whether it rises to the specified pressure. Check the charge pump and the valve. Replace the abnormal item. |

29. TROUBLESHOOTING

| HST Pump | | | |
|----------|------------------------------------|------------------------------------------------------------------------------------------------------|-------------------------------------------------------------------------------------------------------------------------------------------------------------------------------------------------------------|
| S. No. | PROBLEM | PROBABLE CAUSES | REMEDIES |
| 4 | Lack of the output rotation speed. | Increasing of the internal leak due to wearing of the frictional portion of the pump or motor parts. | <p>Check the HST output speed rises to specified value.</p> <p>Replace the HST after cleaning the hydraulic circuit equipment.</p> |
| 5 | Unusual sounds from the HST | Aeration to the inside of the HST. | <p>Check the oil level of tank.</p> <p>Check the piping for any abnormality. (Air suction due to seal failure.)</p> <p>Repair piping. Refill the hydraulic fluid. Degas the hydraulic fluid in the HST.</p> |
| | | Lack of the flow rate in the hydraulic circuit caused by the clogging of the filter or the strainer. | <p>Measure the charge circuit pressure. And check the pressure rises to the specified pressure.</p> <p>Replace or wash the filter and the strainer.</p> |
| | | Looseness or wearing of the linkage of the vehicle | <p>Check the abnormal noise whether decreasing when the linkage part is suppressed by hand.</p> <p>Adjust or repair the linkage parts.</p> |
| | | The increasing of the backlash of the input, output or PTO shaft and its coupling. | <p>Check the input, output or PTO shaft and the coupling for looseness or abrasion.</p> <p>Replace the coupling. Replace the input, output or PTO shaft.</p> |

29. TROUBLESHOOTING

| HST Pump | | | |
|----------|------------------------------------------------------------------------|----------------------------------------------------------------------------------------------------------------------|---------------------------------------------------------------------------------------------------------------------------------------------------------------------------------------------------------------------|
| S. No. | PROBLEM | PROBABLE CAUSES | REMEDIES |
| 5 | Unusual sounds from the HST | Damage to the main parts of the HST. | <p>Check the HST output speed rises to the specified value.</p> <p>Replace the HST after cleaning the hydraulic circuit equipment.</p> |
| 6 | Oil leakage from the shaft and the sealing portion. | Oil leakage due to the damage of the oil seal, O-ring, gasket, etc. caused by the abnormal oil temperature increase. | <p>Measure the oil temperature and check the oil temperature not exceeding the specified value.</p> <p>If the hydraulic circuit equipment (oil cooler, etc.) is abnormal, repair it. Replace the sealing parts.</p> |
| | | Oil leakage due to the damage of the oil seal, O-ring, gasket, etc. caused by the excessive case internal pressure. | <p>Measure the HST case pressure and check the pressure not exceeding the specified value.</p> <p>If the piping is abnormal, repair it. Replace the sealing parts.</p> |
| 7 | Pedal is slow or stiff to return. (Increasing of the stop distance) | The increasing of HST operating torque. (The increasing of hysteresis.) | <p>Measure the operating torque of the trunnion shaft.</p> <p>Replace the swash plate bushing. Wash the swash plate.</p> |
| | | The decreasing of the force of the linkage return spring. The increasing of the friction of linkage bearing parts. | <p>Measure the return spring force. Check the actuating of the linkage parts.</p> <p>Replace the linkage parts and return spring. Adjust the return spring force.</p> |

INDEX

| | | | |
|--------------------------------------|--------|----------------------------------------------------|--------|
| A | | Method of coupling shafts | 4-10 |
| Assemble of pump | 26-101 | Method of coupling trunnion | 4-10 |
| Assembly of Differential Cage Sub | 19-64 | | |
| Assembly of Differential Housing | 25-82 | N | |
| Assembly of Drop Box Mid PTO | 24-79 | Notes in handling | 2-7 |
| Assembly of PTO Sub | 22-73 | Notes on maintenance and storage | 2-8 |
| Assembly of Range Lay Shaft | 21-70 | Notes on mounting and removing | 2-7 |
| Assembly of Tail Pinion Shaft | 20-67 | Notes on product operating | 2-7 |
| Assembly of Trumpet Housing | 23-75 | | |
| | | O | |
| C | | Oil temperature control | 4-16 |
| Charge circuit | 3-9 | | |
| Contamination control | 4-10 | P | |
| | | Piping | 4-16 |
| D | | Pressure measurement procedure | 28-109 |
| Differential Backlash Adjustment | 27-108 | Pump and Motor | 3-9 |
| Dis-assembly Differential Cage Sub | 18-61 | | |
| Dis-assembly of Differential Housing | 13-32 | S | |
| Disassembly of PTO Sub Assembly | 17-60 | Safety: Danger, Warning and Caution | 1-6 |
| Disassembly of Pump | 12-26 | Service Schedule | 10-23 |
| Disassembly of Range Lay Shaft | 16-57 | Special Service Tool | 11-24 |
| Disassembly of Tail Pinion Shaft | 15-54 | Starting up | 4-15 |
| Disassembly of Trumpet Housing | 14-52 | | |
| | | T | |
| H | | Timing of Check and Replacement of Hydraulic Fluid | 5-17 |
| HST Hydraulic Circuit Diagram | 4-14 | Transmission Oil Filler Plug/Dipstick | 7-19 |
| HST operating | 3-9 | Troubleshooting | 29-112 |
| HST Power Flow Chart | 8-20 | | |
| Hydraulic Filter Bleeding Procedure | 4-15 | | |
| Hydraulic fluid | 4-10 | | |
| | | | |
| M | | | |
| Main Dimension | 6-18 | | |

SERVICE MANUAL

H24 HYDROSTAT CABIN

Transmission